



# OPERATOR'S MANUAL

EC220E





**⚠ WARNING:** Breathing diesel engine exhaust exposes you to chemicals known to the State of California to cause cancer and birth defects or other reproductive harm.

- Always start and operate the engine in a well-ventilated area.
- If in an enclosed area, vent the exhaust to the outside.
- Do not modify or tamper with the exhaust system.
- Do not idle the engine except as necessary.

For more information go to [www.P65warnings.ca.gov/diesel](http://www.P65warnings.ca.gov/diesel).

**⚠ ADVERTENCIA:** Respirar los gases del escape de motores a diésel le expone a químicos conocidos por el Estado de California como causantes de cáncer y defectos de nacimiento u otros daños reproductivos.

- Siempre encienda y opere el motor en un área bien ventilada.
- Si es en un área cerrada, ventile el orificio del escape hacia el exterior.
- No modifique ni altere el sistema de escape.
- No encienda el motor, excepto cuando sea necesario.

Para mayor información visite [www.P65warnings.ca.gov/diesel](http://www.P65warnings.ca.gov/diesel).

**⚠ WARNING:** Operating, servicing and maintaining a passenger vehicle or offroad vehicle can expose you to chemicals including engine exhaust, carbon monoxide, phthalates, and lead, which are known to the State of California to cause cancer and birth defects or other reproductive harm. To minimize exposure, avoid breathing exhaust, do not idle the engine except as necessary, service your vehicle in a well-ventilated area and wear gloves or wash your hands frequently when servicing your vehicle. For more information go to [www.P65Warnings.ca.gov/passenger-vehicle](http://www.P65Warnings.ca.gov/passenger-vehicle).

**⚠ ADVERTENCIA:** Operar, dar servicio y mantenimiento a un vehículo de pasajeros o vehículo todo terreno puede exponerle a químicos incluyendo gases del escape, monóxido de carbono, ftalatos y plomo, los cuales son conocidos por el Estado de California como causantes de cáncer y defectos de nacimiento u otros daños reproductivos. Para minimizar la exposición, evite respirar los gases del escape, no encienda el motor excepto si es necesario, dé servicio a su vehículo en un área bien ventilada y utilice guantes o lave sus manos frecuentemente cuando dé servicio a su vehículo. Para mayor información visite [www.P65Warnings.ca.gov/passenger-vehicle](http://www.P65Warnings.ca.gov/passenger-vehicle).



# EC220E L/EC220E LD/EC220E LR/EC220E N/EC220E NH/EC220E NL/EC220E NLD

## Foreword

This operator's manual is intended as a guide for the correct use and maintenance of the machine. Read this manual carefully before you start and move the machine or before you carry out any preventive maintenance.

Keep this manual in the lockable storage compartment so that it is always available for easy reference. Replace it immediately if it is lost.

The operator's manual describes the applications for which the machine was primarily designed. It has been written to be valid on all markets. Therefore, please ignore any sections which do not relate to your machine or to the work that you do with your machine.

### NOTE!

If the manual covers more than one machine, the information relates to all machines unless otherwise specified.

When designing this machine, much time has been invested in achieving the best possible efficiency and safety. But accidents do happen, and most of them can be attributed to human error. A safety-conscious person and a well-maintained machine make up a reliable, powerful, and profitable combination. **Therefore, read the safety instructions and follow them.**

We constantly strive to develop and improve the efficiency of our products by making changes to their design. We reserve the right to make design modifications to the products even after they have been delivered. Also, we reserve the right to change data and equipment, as well as the service and maintenance instructions, without prior notice.

## OPERATOR'S MANUAL

Table of contents

Presentation

Instrument panels

Other controls

Operating instructions

Operating techniques

 Safety when servicing

Maintenance

Specifications

Alphabetical index

## Foreword

## 2

---

**Safety regulations**

The machine operator is responsible for being aware of and complying with the relevant, legally prescribed, national and regional safety instructions. The safety instructions in this operator's manual are applicable only in cases where no legislated safety instructions are in force.

 **DANGER**

The safety symbol combined with this signal word indicates a hazardous situation which, if not avoided, ***will result in death or serious injury***. Danger is limited to the most extreme situations.

 **WARNING**

The safety symbol combined with this signal word indicates a hazardous situation which, if not avoided, could result in ***death or serious injury***.

 **CAUTION**

The safety symbol combined with this signal word indicates a hazardous situation which, if not avoided, could result in ***moderate or minor injury***.

**NOTICE**

Indicates a potentially hazardous situation which may result in machine damage.

**NOTE!**

Used in order to refer to installation, operating, or maintenance information which is important but not danger-related.

**Get to know the capacity and limits of your machine!**





## Identification numbers

Make a note below of the identification numbers of the machine and its components. Always use this information when contacting the manufacturer and when ordering spare parts.

<b>Manufacturer:</b>	Volvo Group Korea Co., Ltd. Seongsan-gu, Changwon-si, Gyeongsangnam-do, Korea 51710
Machine PIN (Serial number)	
Engine	
Main pump	
Swing motor	
Track motor	
Main control valve	

Please send any comments about the Operator's Manual to [om@volvo.com](mailto:om@volvo.com).



A series of horizontal dotted lines for writing, consisting of 20 lines spaced evenly down the page.



## Table of contents

<b>Foreword</b> .....	<b>1</b>
Identification numbers .....	3
<b>Presentation</b> .....	<b>9</b>
Machine view .....	18
CE-marking, EMC-directive .....	19
Communication equipment, installation .....	22
Safety components .....	23
Product plates .....	24
Information and warning decals .....	26
<b>Instrument panels</b> .....	<b>34</b>
Instrument panel, left .....	35
Instrument panel, front .....	37
Display unit .....	43
Instrument panel, right .....	79
Instrument panel, rear .....	92
<b>Other controls</b> .....	<b>93</b>
Controls .....	94
Cab .....	105
Control lockout system .....	109
Operator comfort .....	110
<b>Operating instructions</b> .....	<b>161</b>
Safety rules when operating .....	167
Measures before operating .....	172
Starting engine .....	173
Hydraulic system, warming up .....	177
Operating .....	179
Exhaust aftertreatment system .....	180
Stopping .....	192
Parking .....	193
Retrieving and towing .....	195
Transporting machine .....	197



Table of contents

---

<b>Operating techniques .....</b>	<b>203</b>
Whole-body vibrations .....	204
Rules for digging .....	206
Working within dangerous areas .....	209
Attachments .....	220
Attachments, connecting and disconnecting .....	222
Buckets .....	240
Hammer .....	242
Working with long range attachments .....	248
Hose rupture valves .....	249
Selecting track shoes .....	251
Lifting objects .....	252
Signalling diagram .....	258
<b>Safety when servicing .....</b>	<b>261</b>
Service position .....	262
Before service, read .....	263
Entering, leaving and climbing the machine	269
Fire prevention .....	270
Handling hazardous materials .....	273
Handling line, tubes and hoses .....	278
<b>Maintenance .....</b>	<b>279</b>
Lubrication and service chart .....	281
Maintenance service, every 10 hours .....	289
Maintenance service, every 50 hours .....	291
Maintenance service, every 250 hours .....	298
Maintenance service, every 500 hours .....	303
Maintenance service, every 1000 hours .....	308
Maintenance service, every 2000 hours .....	311
Maintenance service, every 4000 hours .....	314
Maintenance service, when required .....	315



Table of contents

---

<b>Specifications .....</b>	<b>343</b>
Recommended lubricants .....	343
Fuel system .....	350
Service capacities and change intervals .....	358
Engine .....	361
Electrical system .....	362
Cab .....	365
Hydraulic system .....	367
Machine weights .....	369
Ground pressure .....	371
Dimensions .....	418
Working ranges .....	430
Recommended bucket sizes .....	434
Digging forces .....	437
Lifting capacities .....	439
Service history .....	469
<b>Alphabetical index .....</b>	<b>473</b>



A series of horizontal dotted lines for writing, consisting of 20 lines spaced evenly down the page.

## Presentation

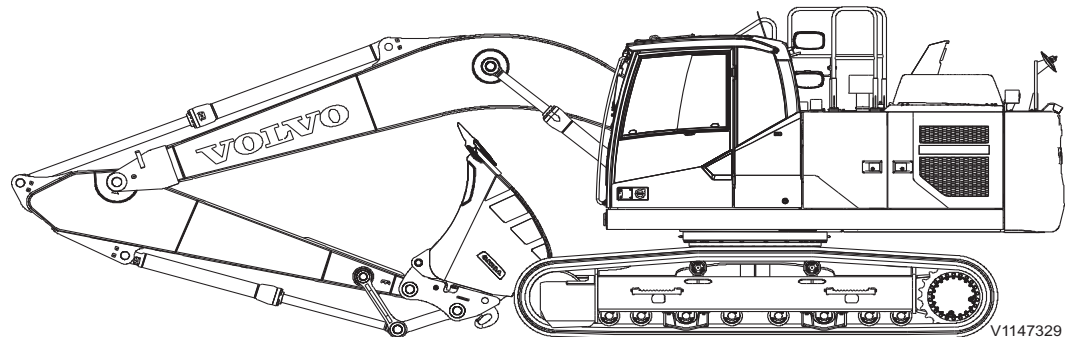

### Intended use

The machine is intended to be used under normal conditions for the applications described in this manual. If it is used for other purposes or in potentially dangerous environments, for example explosive atmosphere, flammable environment or areas with dust containing asbestos and so on, special safety regulations must be followed and the machine be equipped for such use. Contact the manufacturer / dealer for further information.

### Environmental requirements

Be aware of the environment when operating and during service and maintenance of the machine. Always follow local and national environmental legislation applicable to all handling of the machine.

### Engine

The machine is equipped with a straight six-cylinder, four-stroke, turbocharged diesel engine with direct injection and charge-air cooler.

The engines are equipped to meet the legal requirements for exhaust emissions according to





US Tier 4 final, California Tier 4 final, or EU Stage V.

**NOTE!**

Machines with engines for the US market may not be sold or used within the EU, and machines with engines for the EU market may not be sold or used within the USA, unless the engine is replaced with an engine valid for the applicable market. The market for which the engine is intended is indicated on the emission plate and by the engine's serial number (see page 24).

In order to reduce nitrogen oxides, particles, hydrocarbons and carbon monoxide, the engine includes external, cooled exhaust gas recirculation (EGR) and an exhaust aftertreatment system (EATS) with AdBlue®/DEF injection.

The exhaust aftertreatment system is a certified spark arrestor in accordance with Directive 97/68/EC and EN 1834.

**AdBlue®/DEF information**

AdBlue®/DEF is needed for the reduction of nitrogen oxides (NO<sub>x</sub>). AdBlue®/DEF is filled in a separate tank on the machine that is completely separate from the fuel tank. AdBlue®/DEF must not be mixed into the diesel tank and diesel must not be mixed into the AdBlue®/DEF.

**For distribution of AdBlue®/DEF (only valid for US market):**

- Volvo CE Customer Support: 1-877-823-1111 (business hours)
- [www.volvoce.com](http://www.volvoce.com) (outside of business hours)

**For distribution of AdBlue®/DEF (all other markets), please contact your local Volvo dealer for more information.**

**See page 316 for information about filling AdBlue®/DEF.**



## Exhaust aftertreatment system

The engine features an exhaust aftertreatment system (EATS) in the form of two mufflers. The first one contains a diesel oxidation catalyst (DOC) and a diesel particulate filter (DPF) to reduce emissions of particulate matter (PM). The second one contains a selective catalytic reduction catalyst (SCR) to reduce nitrogen oxide (NO<sub>x</sub>) emissions. AdBlue®/DEF is injected into the exhausts in order to reduce NO<sub>x</sub>.

The DPF traps particles from the engine exhausts and, since it is continuously loaded with these particles from the exhausts, it needs to be regenerated in order to burn off the particles. Regeneration is also required to release trapped sulphur (SO<sub>2</sub>) and other substances that are trapped in the SCR and reduce the SCR's efficiency if they are not removed.

In order to ensure reduction of NO<sub>x</sub>-emissions, the EATS is monitored by the aftertreatment control module (ACM).

For more information, see page 180.

## Electrical system

The electrical system consists of engine starting system, charging system, machine monitoring system, engine / pump control system and air conditioning system.

The machine is equipped with a high capacity electrical system well protected. Waterproof double-lock harness plugs are used to secure corrosion-free connections. The main relays and solenoid valves are shielded to prevent damage. The master switch is standard.

## Automatic idling system

Automatic idling system reduces engine speed to idle when the levers and pedals are not activated for a certain period of time, resulting in less fuel consumption and low cab noise level.

## Automatic engine shut-down system

### (Optional equipment)

Automatic engine shut-down system is to stop the engine automatically when the machine is not operated for a certain period of time. Default time is set at 5 minutes and can be changed with Volvo's service tool only. Contact a workshop authorized by Volvo.

### Automatic engine shut-down conditions

- Control lockout lever is down.
- Engine speed control switch is not changed.
- DPF regeneration is not on progress.

1 minute before engine shut-down, info screen will be displayed on IC (Instrument Cluster) so that the operator can cancel engine shut-down by pushing the keypad ESC button or moving the control lockout lever up or changing engine speed control switch (at the control lockout lever down position).



## Cab

The operator's cab has easy access via a wide door opening. The cab is supported on hydraulic dampening mounts to reduce shock and vibration level. These along with sound absorbing lining provide low noise levels. The cab has excellent all-round visibility. The front windshield can easily slide up into the ceiling, and the lower front glass can be removed and stored in the side door.

### **Integrated air-conditioning and heating system**

The pressurized and filtered cab air is supplied by an automatically-controlled fan. The air is distributed throughout the cab from 14 vents.

### **Ergonomic operator's seat**

The adjustable seat and joystick console move independently to accommodate the operator. The seat has 12 different adjustments plus a seat belt for the operator's comfort and safety.

### **FOPS and FOG**

The cab is designed to meet the requirements for falling objects, the weight of which agrees with testing methods according to FOPS and FOG. The cab is approved as a part of protective structure according to FOPS and FOG standards. (FOPS: ISO10262 (Level II), FOG: ISO10262:1998 (Level II) and SAE J1356)

FOPS is an abbreviation of Falling Object Protective Structure (top guard) and FOG is an abbreviation of Falling Object Guard (top guard and front guard).

### **ROPS**

The cab is approved as a part of protective structure according to ROPS standard (ISO12117-2).



## Hydraulic system

The hydraulic system, known as the "Automatic Sensing Work Mode" is designed for high-productivity, high-digging capacity, high-maneuvering precision and excellent fuel economy. The summation system, priority systems, and regeneration system provide optimum performance.

- 1 Summation system: Combines the flow of both hydraulic pumps to ensure quick cycle times and high productivity.
- 2 Boom priority: Gives priority to the boom up function for faster cycle times during loading and deep excavations.
- 3 Arm priority: Gives priority to the arm operating function for faster cycle times during digging and dumping.
- 4 Swing priority: Gives priority to the swing function during trenching application to improve productivity.
- 5 Regeneration system: Prevents cavitation and provides flow to other functions during simultaneous operations for maximum productivity.
- 6 Power boost: All digging and lifting forces are increased.
- 7 Holding valves: Boom and dipper arm holding valves are provided to minimize cylinder drifting while holding loads.



---

### Track motor and gearbox

The track motor is a variable axial piston motor that consists of a housing, a rotary group and a port plate. The housing contains the swash angle control screw. The rotary group consists of the cylinders and the pistons. The port plate consists of the counterbalance valve, the check valves, the relief valves and the displacement changeover valve. Track motor also includes the spring applied, hydraulically released parking brake assembly. The gearbox has a two-stage planetary mechanism has two sets of sun gears, planetary gears and pinion gears, driven by the splined output shaft of the track motor mounted directly to the gearbox.

### Swing motor and gearbox

The swing motor is a fixed axial piston motor. The rotary group consists of a cylinder block and nine pistons located in the cylinder. The cover section has relief valves, an anti-cavitation valves and anti-rebound valves. The housing has a time delay valve and a disk type brake.

The gearbox is composed of the sun gear, the planetary gear, the pinion gear and the housing. The power supplied to the output shaft of the swing motor reduces motor speed through the sun gear and the planetary gear, developing high torque that is transmitted to the pinion gear.



## Equipment

The machine can be equipped with different types of optional equipment, depending on the requirements of different markets. Examples of such equipment are automatic engine shutdown, and automatic lubricating system (standard on certain markets).

## Modifications

Modifications of this machine and its components such as engine and auxiliary system, including the use of unauthorized attachments, accessories, units, or parts, may affect the machine's integrity (condition), the machine's ability to function in the way for which it is designed and voids the EU type-approval of the machine and engine- and auxiliary system. Persons or organizations performing unauthorized modifications assume all responsibility for consequences that arise due to modifications or can be attributed to modifications, including damages to the machine.

No modifications of any kind may be performed on this product unless each specific modification first has been approved in writing by Volvo Construction Equipment. Volvo Construction Equipment reserves the right to reject all warranty claims that have arisen due to or can be traced to unauthorized modifications.

Modifications may be considered to be officially approved, if at least one of the following conditions has been met:

- 1 The attachment, the accessory, the unit, or the part has been manufactured or distributed by Volvo Construction Equipment and has been installed according to the factory-approved method described in a publication available from Volvo Construction Equipment; or
- 2 The modification has been approved in writing by the Engineering Department for the relevant product line at Volvo Construction Equipment.





### **Anti-theft device (optional equipment)**

An installed anti-theft device makes it more difficult to steal the machine. Volvo Construction Equipment can supply an anti-theft device as optional equipment. If your machine is not equipped with such a device, look into the possibility of having one installed by a qualified service technician.

### **Logged machine data**

The machine is equipped with a software system, which records various information about the machine and this information is transferred from the machine to Volvo and used by Volvo and its authorized workshops in the product development process and for possible malfunction detection. Questions regarding this information can be directed to your dealer.

### **CareTrack**

The machine may be equipped with CareTrack, a telematics system developed by Volvo Construction Equipment. The system stores machine data, e.g., machine position, operating hours, fuel consumption, fuel level, that can be sent by wireless transmission to a computer. CareTrack is available in different versions, depending on the required information level.

CareTrack makes it easier to plan for service and reduces costly downtime. Productivity is improved by knowing if machines are being operated correctly and how much fuel is being consumed. CareTrack also allows the customer to restrict the operating area of the machine, by using virtual fences. This helps to eliminate unauthorized machine use and theft. For further information, contact a Volvo Construction Equipment dealer.

The CareTrack system transmits data, in the same way a mobile phone does, with a maximum output rate of 10 W. The transmitter is always on and the operator cannot switch it off.

Local precautions and restrictions applicable to mobile phones, for example safety distance, also apply to the CareTrack system.

18 Presentation  
Machine view

Machine view

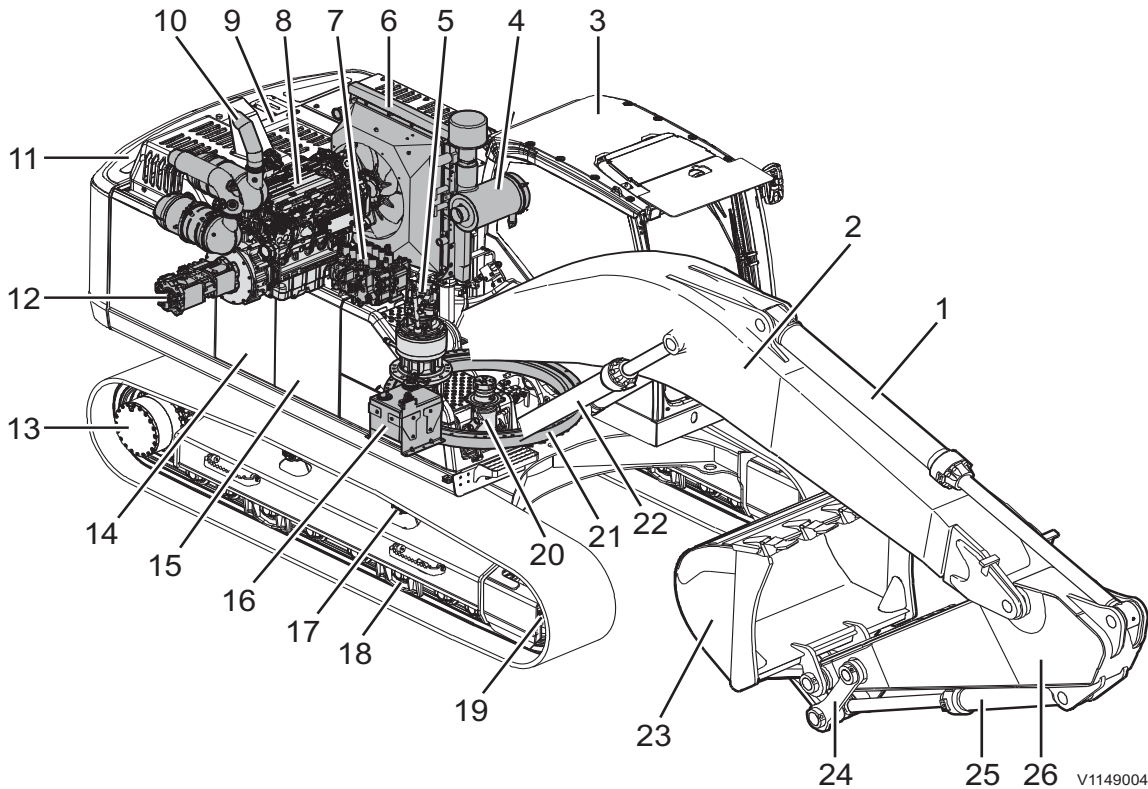

1	Dipper arm cylinder	14	Hydraulic tank
2	Boom	15	Fuel tank
3	Operator cab	16	AdBlue®/DEF tank
4	Air cleaner	17	Top roller
5	Swing motor and gearbox	18	Bottom roller
6	Charge air cooler, hydraulic oil cooler, and radiator	19	Idler
7	Main control valve	20	Turning joint
8	Engine	21	Swing ring gear
9	Rear hood	22	Boom cylinder
10	Muffler	23	Bucket
11	Counterweight	24	Link
12	Main pump	25	Bucket cylinder
13	Track motor and gearbox	26	Dipper arm

## CE-marking, EMC-directive

### CE marking

**(Declaration of Conformity : Only applies to machines marketed within the EU/EEA.)**

This machine is CE marked. This means that when delivered the machine meets the applicable "Essential Health and Safety Requirements", which are given in the EU Machinery Safety Directive, 2006/42/EC.

Any person carrying out changes that affect the safety of the machine, is also responsible for the same.

As proof that the requirements are met, the machine is supplied with an EU Declaration of Conformity, issued by Volvo CE for each separate machine. This EU declaration also covers attachments manufactured by Volvo CE. The documentation is a valuable document, which should be kept safe and retained for at least ten years. The document should always accompany the machine when it is sold.

If the machine is used for other purposes or with other attachments than described in this manual, safety must at all times and in each separate case be maintained. The person carrying out such action is also responsible for the action which, in some cases, may require a new CE marking and the issue of a new EU Declaration of Conformity.



V1067840



### EU EMC Directive

The electronic equipment of the machine may in some cases cause interference to other electronic equipment, or suffer from external electromagnetic interference, which may constitute safety risks.

The EU EMC directive about "Electromagnetic compatibility", 2014/30/EC, provides a general description of what demands can be made on the machine out of a safety point of view, where permitted limits have been determined and given according to international standards.

A machine or device which meets the requirements should be CE marked. Our machines have been tested particularly for electromagnetic interference. The CE marking of the machine and the declaration of conformity also cover the EMC directive.

If other electronic equipment is fitted to this machine, the equipment must be CE marked and tested on the machine with regard to electromagnetic interference.



**EC DECLARATION OF CONFORMITY FOR MACHINERY (IIA)**

Volvo Construction Equipment hereby declares that the below specified product:

- Manufacturer:** Volvo Construction Equipment AB
- Address:** 160, Doosanvolvo-ro, Seongsan-gu, Changwon-si, Gyeongsangnam-do, 642-430
- Country:** Korea
- Category:** Earth Moving Machinery
- Make:** Volvo
- Type:** Hydraulic Excavator
- Model:** ECXXXX, ECRXXXX, EWXXXX
- Power [kW]:** XXX
- Representative sound pressure [dB(A)]:** XXX
- Guaranteed sound pressure [dB(A)]:** XXX
- PIN:** \*VCEXXXXXXXXXXXXXXXXX\*
- In conjunction with**
- Type:** N/A
- Model:** N/A
- s/n:** N/A

in the state in which it was placed on the market, and excluding components added and/or operations carried out subsequently is in conformity with the relevant provisions of Essential Health and Safety requirements of:

- EC Directive "Machinery":** 2006/42/EC
  - EC Directive "Outdoor Noise":** 2000/14/EC
  - EC Directive "Electromagnetic Compatibility":** 2014/30/EC
- and their amendments relating to machinery, and other applicable directives

The following harmonized standards apply:

- Earth Moving machinery - Safety Part 1:** EN 474-1:2006+A5:2018
- Earth Moving machinery - Safety Part 5:** EN 474-5:2006+A3:2013
- Technical file compiled by:** XXXXXX, D-54329 KONZ, Germany
- Notified Body:** 1067; AV Technology Ltd., AVTECH House, Birdhall Lane, Cheadle Heath, Stockport. SK3 0XU, UK.

This declaration includes attachments developed designed/approved, marked and marketed by above-mentioned manufacturer.

the identity and signature of the person empowered to draw up the declaration on behalf of the manufacturer

the identity and signature of the authorised representative

XXXXXX; XXXXXX

Changwon, Korea	dd/mm	yyyy	Place	date	year
-----------------	-------	------	-------	------	------

## Communication equipment, installation

### **NOTICE**

All installation of optional electronic communication equipment must be performed by trained professionals and in accordance with the Volvo Construction Equipment instructions.

### **Protection against electromagnetic interference**

This machine has been tested in accordance with EU directive 2014/30/EC governing electromagnetic interference. It is therefore very important that all non-approved electronic accessories, such as communication equipment, should be tested before installation and use, since they can cause interference to the electronic systems of the machine.

### **Guidelines**

The following guidelines must be followed during installation:

- The antenna placement must be chosen to give good adaptation to the surroundings.
- The antenna cable must be of the coaxial type. Be careful to ensure that the cable is undamaged, that the sheath and braid are not split at the ends, the braid covers the connector ferrules and has good galvanic contact with them.
- The mating surface between the antenna mounting bracket and the bodywork must have clean metal surfaces, with all dirt and oxide removed. Protect the mating surfaces against corrosion after installation to maintain good galvanic contact.
- Remember to separate interfering and interfered cables physically. Interfering cables consist of the communication equipment's supply cables and antenna cable. Interfered cables are those which are connected to electronic devices in the machine. Install the cables as close as possible to earthed (grounded) sheet metal surfaces, since the sheet metal has a shielding effect.



## Safety components

Genuine Volvo spare parts guarantee the best service life, reliability, and safety for the machine and operator. If reliable and purpose-built parts are not used, your safety, health, and the machine's function may be compromised. Contact your dealer and state the machine's model designation/serial number (PIN-number) when ordering spare parts. Position of PIN-plate, see section "Product plates".

Your Volvo dealer always has up-to-date spare part information that is updated at regular intervals via the information system PROSIS.

### Safety-classified machine and spare parts

Safety-classified machine and spare parts means that the components are intended to fulfil a safety function.

### Examples of safety-classified machine parts/ spare parts

- Removable protective devices/guards over rotating parts and hot surfaces
- Protective plates, rails, covers, and steps
- Components included in systems to reduce sound and vibrations
- Components included in systems to improve the operator's visibility
- Complete operator's seat incl. seat belt
- Decals and plates
- Cab filter

### NOTE!

Safety-classified machine and spare parts shall be reinstalled, repaired, or replaced immediately if they have been removed or damaged.

When changing machine operator/owner, malfunctions and defects of safety-classified machine and spare parts shall be reported immediately and an action plan shall be established.

There is more important information in this Operator's Manual about the components that are considered safety-classified.



## Product plates

Please refer to the figure below to locate the product plate, engine plate, cab plate and attachment plates. Always use the Product Identification Number (PIN) provided on the vehicle and/or engine plates for troubleshooting purposes and/or when ordering spare parts.

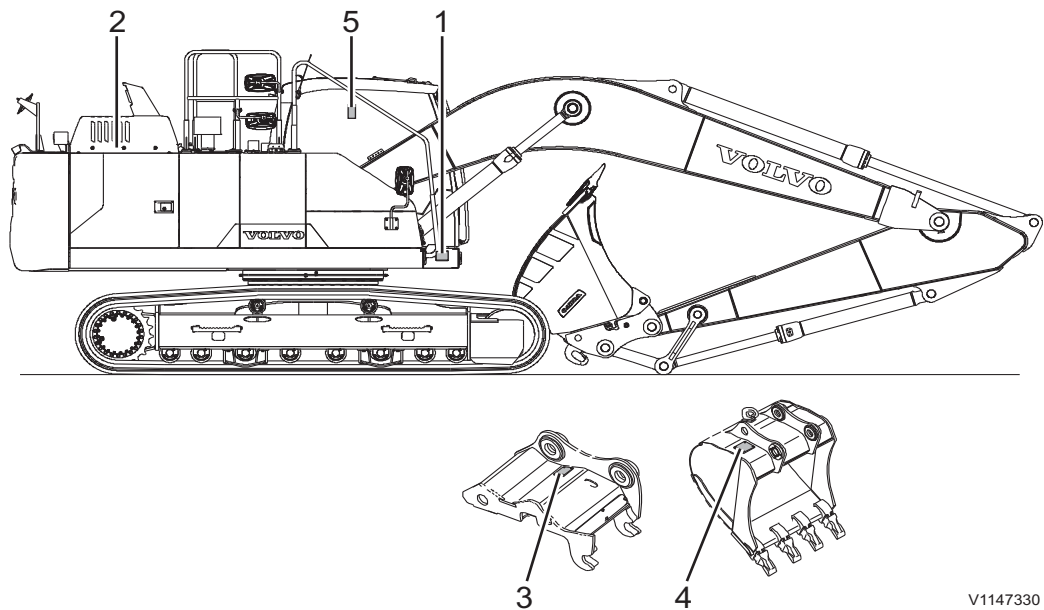

V1147330

### 1 Product plate

This plate with Product Identification Number, PIN, for the complete machine indicates the model designation, serial number and when applicable, machine weight, engine power, manufacturing year and CE approval. The plate is positioned on the right side of the superstructure.

### 2 Engine

The engine type designation, part and serial numbers are stamped on the top of valve cover.



---

### **3 Attachment quick coupler**

This nameplate is attached on the outside of the quick coupler and indicates the supplier code, serial number, part number and weight.

### **4 Bucket**

This nameplate is attached on the top of the bucket and indicates the bucket model order number, serial number, supplier code, rated capacity, weight, cutting width, tooth part number and adapter part number.

### **5 Cab**

The nameplate is attached on the inside of the cab and indicates the product number, serial number, model type, and weight.

## Information and warning decals

Information and warning decals are affixed to the machine on strategic locations to remind operators and maintenance personnel specific safety precautions. All decals are not installed on all machines, as they are market and machine dependent. The decals must be kept free from dirt, so that they can be read and understood. If a decal is lost or becomes illegible, it must be replaced immediately. The part number (order number) is given on the respective decals and in the Parts Catalogue.

**NOTE!**

The word WARNING is given on the warning decals for North America.

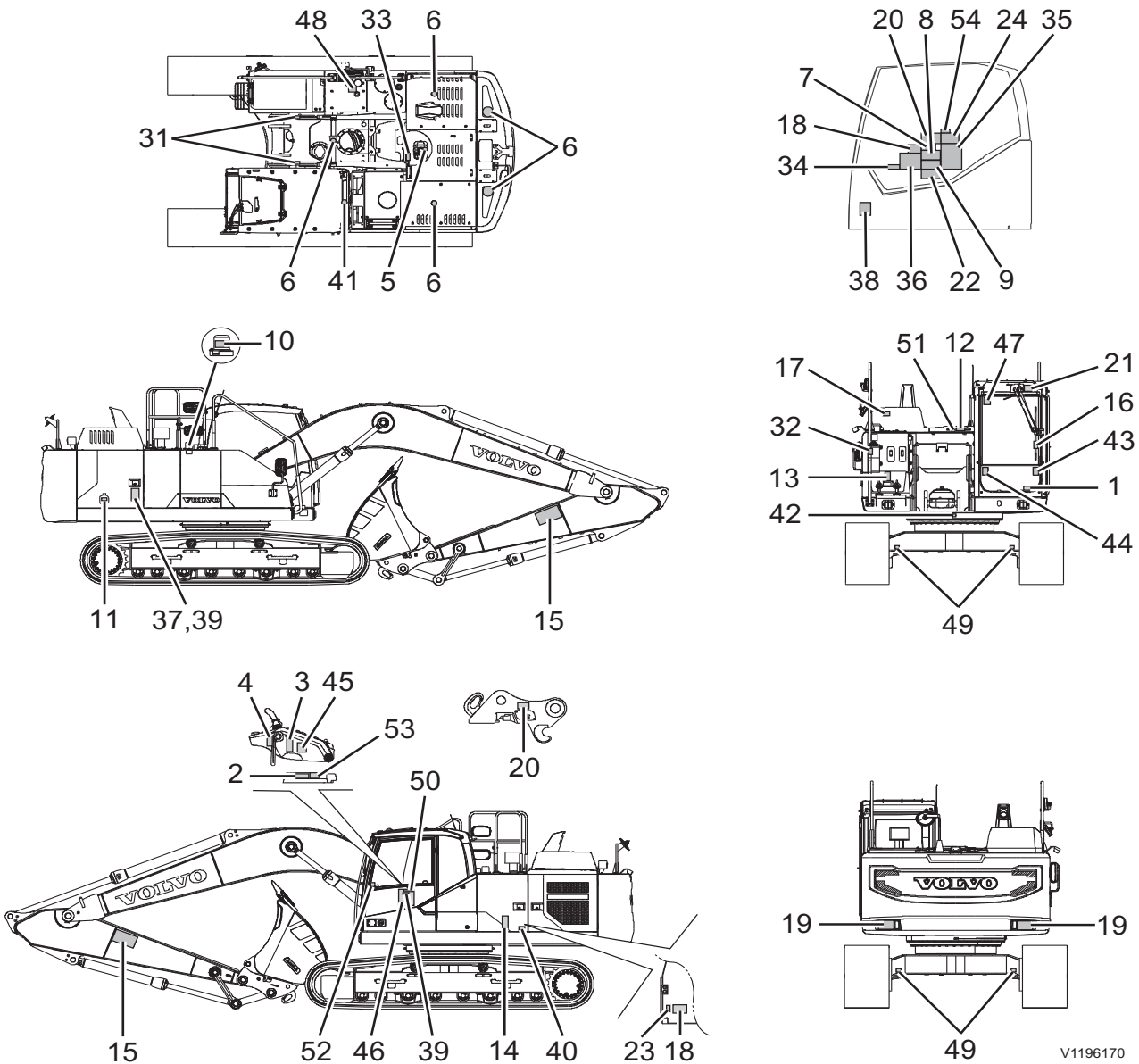

Warning decals



V1079477

- 1 **WARNING!** Read the Operator's manual.

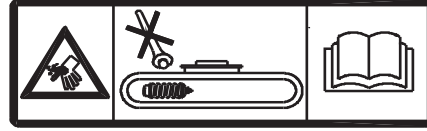

V1065357

- 2 **WARNING!** High pressure, do not unscrew the recoil spring when tensioning tracks – read the Operator's manual. See page 332.

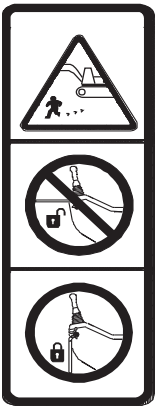

V1065342

- 3 **WARNING!** When leaving the machine, move the control lockout lever down to lock the hydraulic system.



V1079483

- 4 **WARNING!** Do not start the engine.



V1065344

- 5 **WARNING!** Hot and pressurised coolant when opening radiator cap.



V1065343

- 6 **WARNING!** Do not step on this surface.

28 Presentation  
Information and warning decals

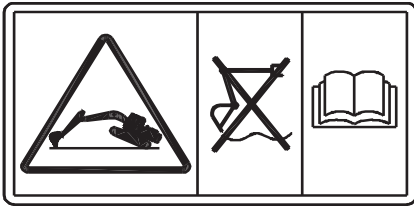

V1092982

7 **WARNING!** Do not use floating function while the machine is jacked up – read the Operator's manual. Boom floating (option). See page 220.

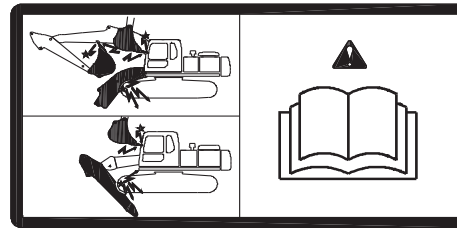

V1093037

8 **WARNING!** Operating the optional attachment. Equipment may strike the cab or machine.

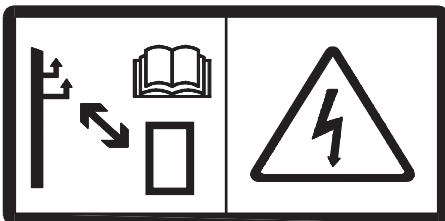

V1079478

9 **WARNING!** High voltage, keep safe distance from electrical power lines. Read the Operator's manual. See page 209.



V1079484

10 **WARNING!** No smoking when fuel filling.



V1079480

11 **WARNING!** Risk of explosion – read the Operator's manual. See page 338.

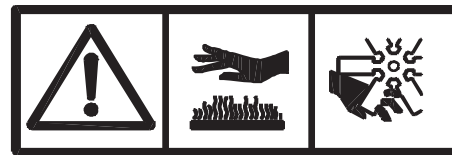

V1079479

12 **WARNING!** Hot surfaces and rotating parts



V1093038

13 WARNING! Risk of falling from machine.



V1077433

14 WARNING! Risk of electrical shock, corrosive burns and explosion – read the Operator's manual.



V1093039

15 WARNING! Raised attachment, keep a safe distance from the machine.



V1065355

16 WARNING! Lock the windshield. WARNING! Insert safety lock before getting into hazardous area.

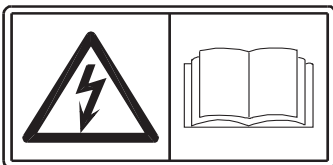

V1134752

17 WARNING! Electric shock.

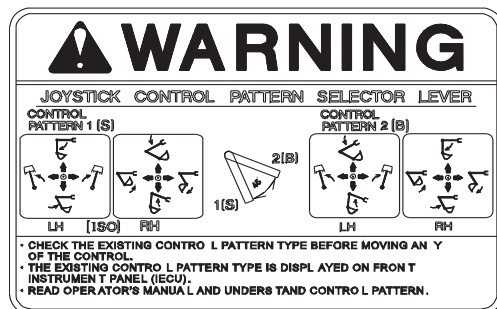

V1065345

18 WARNING! Pattern change valve selector (option). See page 94.

30 Presentation  
Information and warning decals

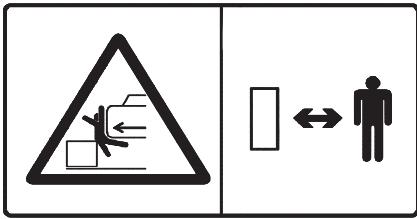

V1065358

19 **WARNING!** Crushing area, keep a safe distance from the machine.

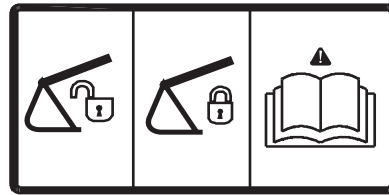

V1093043

20 **WARNING!** Before working after connecting and disconnecting attachment – read the Operator's manual. (Attachment quick coupler, option)

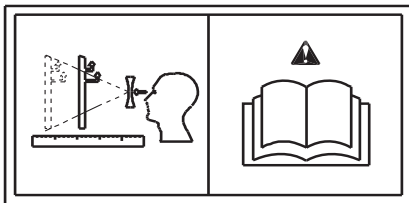

V1093040

21 **WARNING!** Risk of visual distortion through roof window – read the Operator's manual.

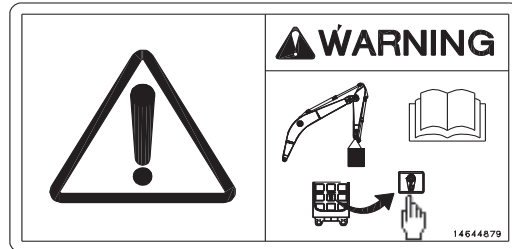

V1123383

22 **WARNING!** Overload warning button. See page 79.

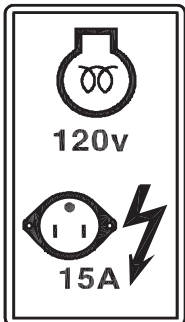

V1093045

23 **WARNING!** Engine preheater (option).

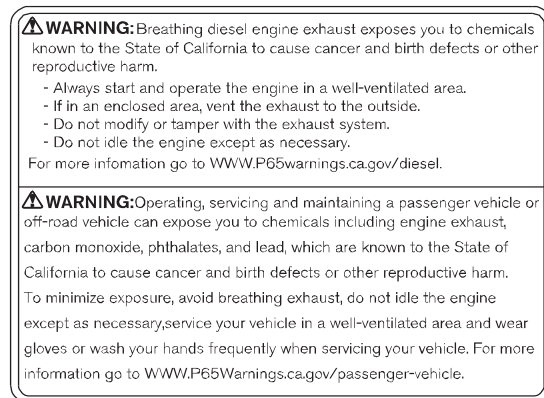

V1196169

24 **WARNING!** California Proposition 65 requirements (for North America).



Information decals



V1065364

31 Lifting point.



V1137928

32 AdBlue®/DEF, filling. See page 316.



V1065366

33 Coolant information – read the Operator's manual. See page 312.

Mode	Applications	
<b>H</b>	Heavy duty	Maximum productivity, High Speed.
<b>G</b>	General	Most general application, Optimum speed.
<b>F</b>	Fine control	Maximum lifting force, Precise control speed.
<b>I</b>	Idle	Warm-up, Low idle speed.

V1065367

34 Mode application (option).

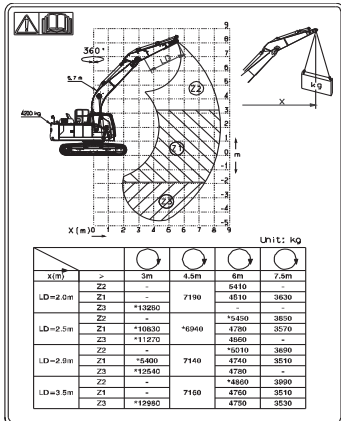

V1148558

35 Lifting capacity (option). See page 439.

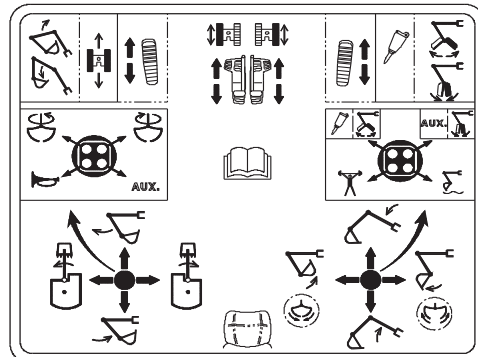

V1099522

36 Lever and pedal functions (option).

32 Presentation  
Information and warning decals

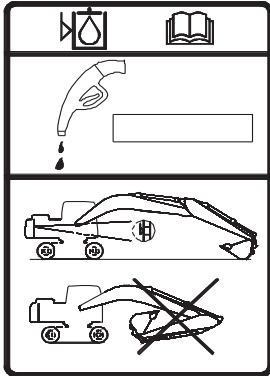

V1065370

37 Machine position when checking hydraulic oil level.



V1093046

39 Type of hydraulic oil filled at factory (option).

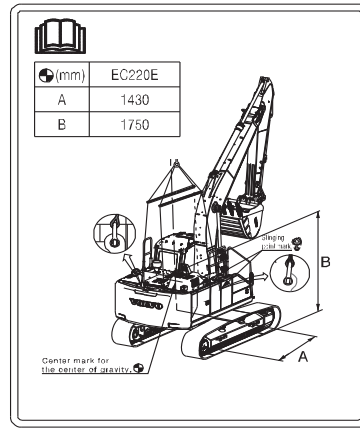

V1148557

38 Lifting instruction. See page 201.

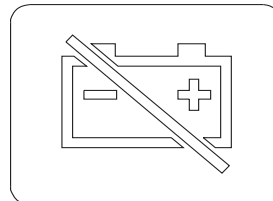

V1125755

40 Battery disconnect switch.



V1093052

41 Sound pressure level in cab (option).

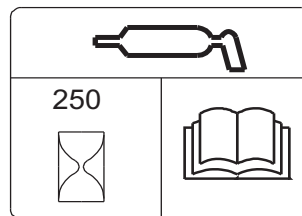

V1065375

42 Greasing interval – read the Operator's manual.

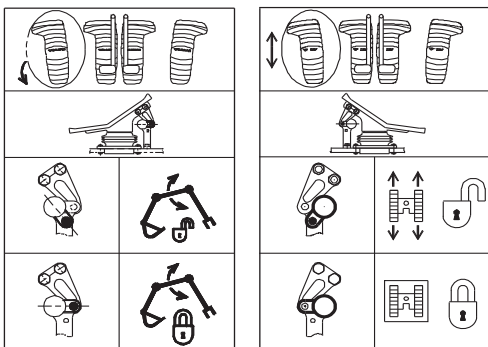

V1068020

43 Optional pedal operation (option).

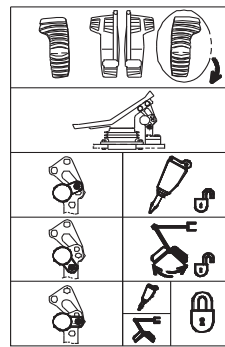

V1065377

44 Optional pedal operation (option).

Presentation  
Information and warning decals



V1068021

45 Sound power level outside machine.

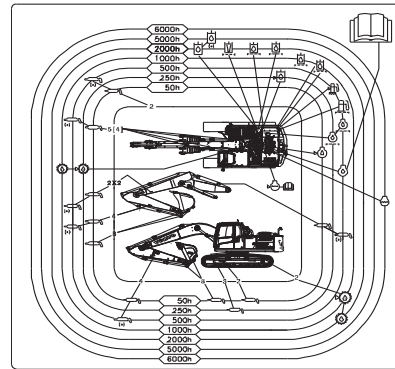

V1148556

46 Lubrication and service chart. See page 283.

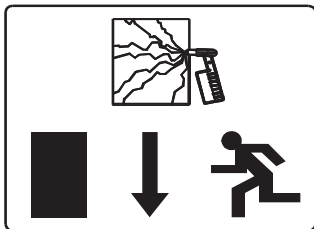

V1129244

47 Emergency exit.

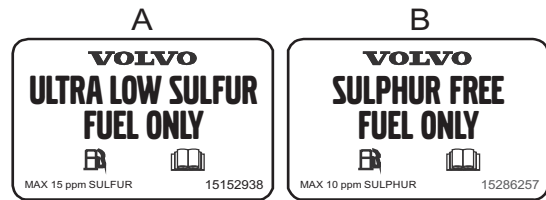

V1099517

48 Sulphur content information (A: for North America, B: for Europe and Other markets). See page 350.



V1065381

49 Tie-down point.



V1065382

50 Long life hydraulic oil. See page 343.

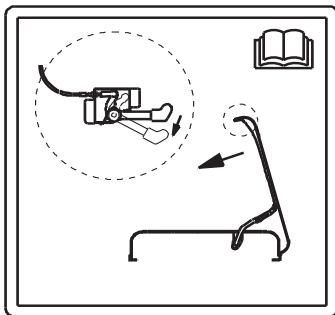

V1068022

51 Hood stay lever operation.

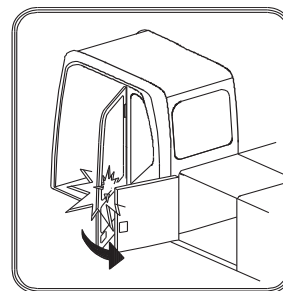

V1065356

52 Be careful when opening the cab door. Risk of cab door window damage.

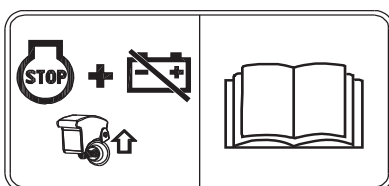

V1137926

53 Emergency stop switch. See page 94.

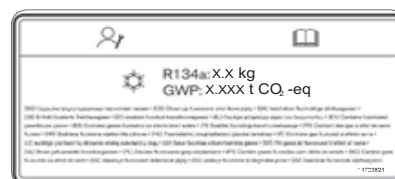

V1178089

54 Refrigerant information. See page 305, 277 and 366.

# Instrument panels

## WARNING

Risk of serious injury.

Operating the machine without sufficient skills and knowledge of the content in the Operator's Manual could lead to loss of machine control and could cause serious injuries including death.

**Carefully read through the Operator's Manual and learn the warning signs, symbols and operating instructions before attempting to operate the machine.**

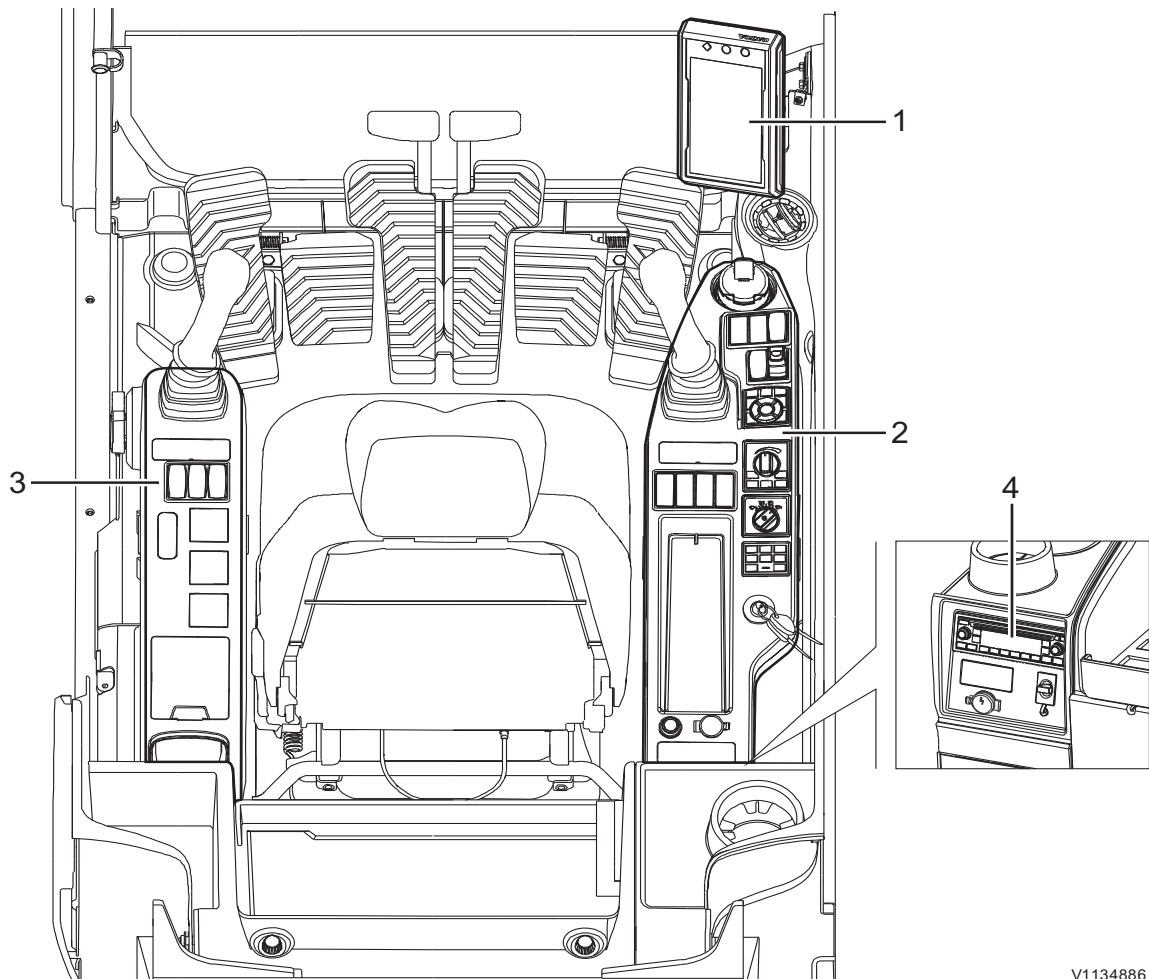

V1134886

1	Front instrument panel (Instrument Cluster)
2	Right instrument panel
3	Left instrument panel
4	Rear instrument panel

## Instrument panel, left

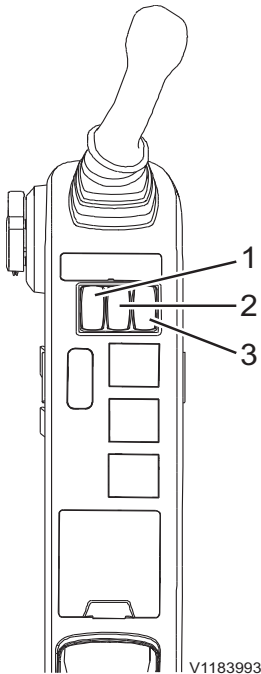

V1183993

- 1 Interior light switch
- 2 Rotating beacon switch (optional equipment)
- 3 Attachment quick coupler switch, left (optional equipment)

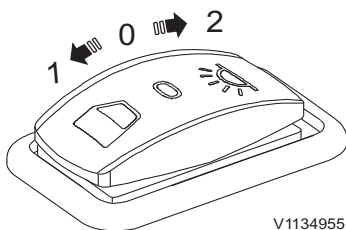

V1134955

### 1 Interior light switch

- Position 0: Interior light is OFF
- Position 1: Interior light (B) will be turned on when the cab door is open. After closing the cab door, the interior light will be turned off automatically.
- Position 2: Interior light is ON

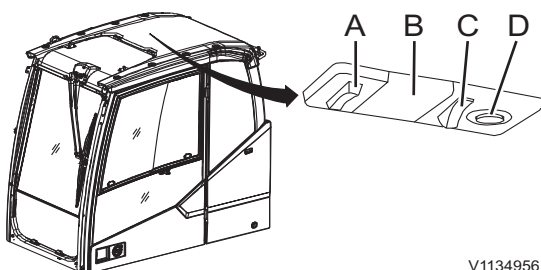

V1134956

The switch (A) for the interior light will only work when this switch is in the "ON" position (2). The reading light (D) can be turned on with switch (C) regardless of the position of the interior light switch.

## 36 Instrument panels Instrument panel, left

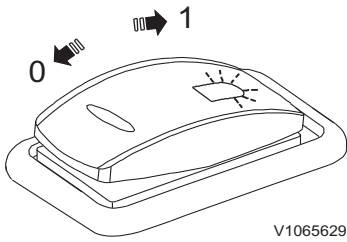

### 2 Rotating beacon switch (optional equipment)

- Position 0: Rotating beacon is OFF
- Position 1: Rotating beacon is ON

This switch is used to activate the rotating beacon when the swing system is activated.

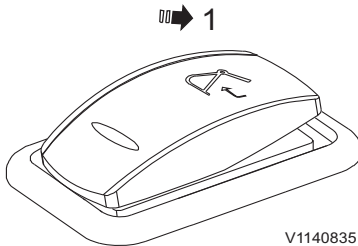

### 3 Attachment quick coupler switch, left (optional equipment)

This switch has 2 different functions of the attachment quick coupler according to the operating condition.

- Press down 1: Attachment quick coupler, opening control

The switch is returned automatically. Press the switch for more than 0.7 seconds to open the attachment quick coupler.

When the attachment quick coupler is open, the buzzer sounds and the warning message and indicator are displayed on the IC (Instrument Cluster).

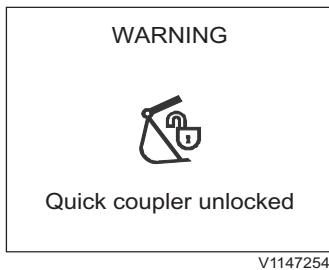

Warning! Quick coupler unlocked

#### NOTE!

The attachment quick coupler switch for initiating on the right instrument panel must be pressed first to activate this switch. See page 79 for the operation.

- Press down 1: Attachment quick coupler, confirming control

When the check message for confirming appears on the IC (Instrument Cluster), press the switch for more than 0.7 seconds to confirm that the attachment quick coupler is locked. Then the buzzer sound will be turned off and the check message and indicator will disappear.

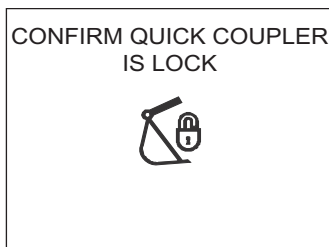

Confirm quick coupler is locked

## Instrument panel, front

The front instrument panel can be adjusted for better operator comfort.

**NOTE!**

Prevent machine damage by taking correct action. Read thoroughly and understand the instructions in this section to familiarize yourself with the front instrument panel before trying to operate the machine.

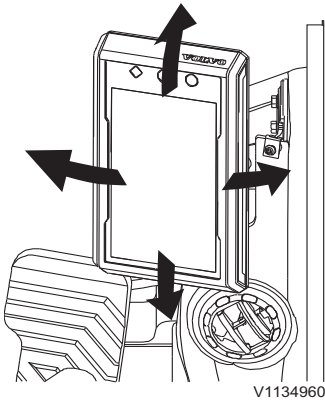

Adjustable direction of IC (Instrument Cluster)

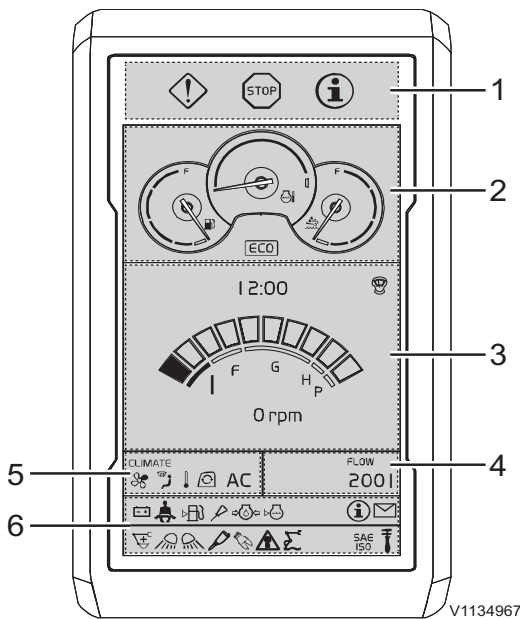

**NOTE!**

The front instrument panel is designed to display one of the supported languages. Refer to page 43 for details on how to set the language and the units.

- 1 Central warning light screen
- 2 Gauge screen
- 3 Time and engine speed screen
- 4 Hydraulic flow screen
- 5 CCM (Climate Control Module) screen
- 6 Indicator screen





A



B



C

V1134961

- A Check, amber
- B Warning, red
- C Information, blue

## 1 Central warning light

There are three different types of light.

For more information, see page 43.

### NOTE!

If the central warning light flashes or lights up while operating, follow the instructions on the display unit.

## 2 Gauges

The gauges are always shown unless a warning message is activated.

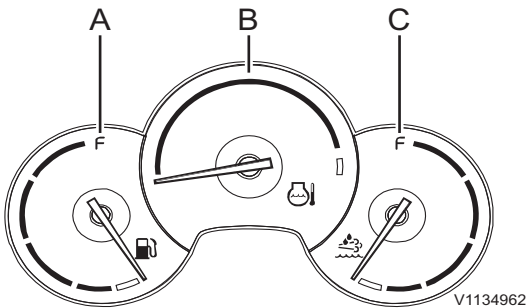

- A Fuel level gauge
- B Engine coolant temperature gauge
- C AdBlue®/DEF level gauge

### Fuel level gauge

The gauge shows the level in the fuel tank and it has a red mark indicating "fuel empty". When the gauge is in this area, the fuel left is about 10% of total tank capacity. Refuel the machine immediately in order to avoid air entering the system. If the machine runs out of fuel during operation, refuel and refer to page 320 for correct instructions to bleed air from the fuel system.

Fuel tank capacity, see page 358.

### Engine coolant temperature gauge

The gauge shows the temperature of the engine coolant and it has a red mark meaning "engine overheated".

### NOTE!

The red central warning light flashes, if the coolant temperature becomes abnormally high. Turn off the engine immediately and check the cause.

### AdBlue®/DEF level gauge

The gauge shows the level in the AdBlue®/DEF tank and it has a red mark indicating "AdBlue®/DEF empty". When the gauge is in this area, the AdBlue®/DEF left is about 10% of total tank capacity.

Capacity of AdBlue®/DEF tank, see page 358.

### 3 Time and engine speed

Time segment displays the current time. Refer to page 43 for instructions on how to set current time on the main screen.

Engine speed screen is displayed when the "Menu screen" is not shown in the "Main screen". For main menu screen, see page 43.

The "Engine speed step" selected on "Engine speed control switch" is displayed on an engine speed graph which is a segmented bar graph.

The actual speed is displayed below the engine speed graph (maximum four-digit number).

When the engine is off, engine speed is displayed as "0".

#### NOTE!

Engine speed and work mode may vary according to the optional equipment.

### 4 Hydraulic flow

Calculated value for X1 flow option is displayed on the segment called "Flow segment". Refer to page 43 for flow setting instructions.

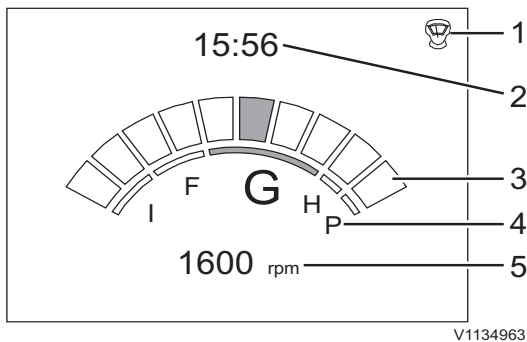

V1134963

- 1 Joystick shortcut
- 2 Time
- 3 Engine speed step
- 4 Work mode index
- 5 Actual engine speed

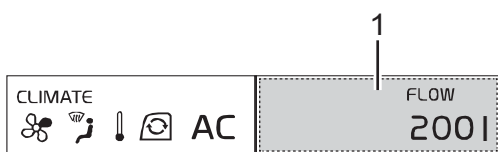

V1134964

- 1 Flow rate for X1

## 40 Instrument panels Instrument panel, front

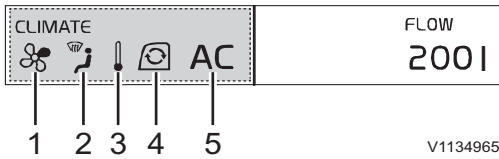

- 1 Fan speed
- 2 Air flow direction
- 3 Temperature
- 4 Air flow circulation
- 5 Air conditioning status

V1134965

### 5 CCM (Climate Control Module)

CCM segment displays the status of the CCM (Climate Control Module). This includes temperature setting, fan speed, air flow direction, circulation, and air conditioning status. Refer to page 115 for more details.

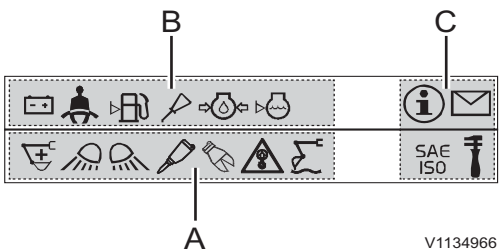

- A Function indicators
- B Warning indicators
- C Fixed indicators

V1134966

### 6 Indicators

Indicator screen displays indicators as symbols that show users important information easily and quickly. Indicators are divided into three types; function indicator, warning indicator, and fixed indicator.

#### NOTE!

Fixed indicators are always displayed on the right side.

- Indicators fill the space from left to right.
- An indicator that has higher priority is put on the left side of the one that has lower priority.
- Indicators on both sides can extend their display area to the other side if there is no indicator on the other side.
- When the whole area is filled and there are more indicators to display, indicators keep replacing the others so that the user can see all indicators.

Instrument panels  
Instrument panel, front

Indicators and their priorities are as follows;

Table. Function indicators

 V1065463	 V1065465
1. Air preheating	2. Hammer selected (optional equipment)
 V1065466	 V1065467
3. Shear selected (optional equipment)	4. Overload indicator (optional equipment)
 V1065468	 V1129236
5. Boom float position (optional equipment)	6. Power boost selected
 V1065469	 V1065470
7. Rototilt selected (optional equipment)	8. Reversible fan (optional equipment)

Table. Warning indicators

 V1065475	 V1065476
1. Low engine oil pressure	2. Low coolant level
 V1065467	 V1065478
3. Overload warning (optional equipment) Stop the lifting operation and reduce the load.	4. Low engine oil level
 V1065479	 V1065480
5. Open attachment quick coupler (optional equipment) Stop work immediately if the bucket is still attached to the attachment bracket.	6. Wrong battery charge

42 Instrument panels  
Instrument panel, front











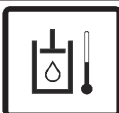

 V1065481	 V1065483
7. High engine coolant temperature	8. Pattern changer warning
 V1065484	 V1065485
9. Clogged engine air filter	10. Auto lubrication warning
 V1065486	 V1065487
11. Low fuel level	12. High hydraulic oil temperature
 V1065488	 V1203413
13. Seat belt	14. AdBlue®/DEF warning
 V1203414	 V1203415
15. Regeneration needed	16. Regeneration, malfunction
 V1203416	
17. High exhaust temperature during regeneration	

Table. Fixed indicators

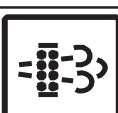
 V1065471	 V1065472
1. Service mode selected (fixed position)	2. Message indicator (fixed position)
 V1065473	 V1065474
3. Pattern changer status (fixed position)	4. Pattern changer status (fixed position)

## Display unit

### Start sequence

Initial start sequence is performed as follows.

#### A Volvo logo

If the operator turns the ignition switch to the operating position, the Volvo logo on the IC (Instrument Cluster) screen lights up for a few seconds.

#### NOTE!

Enter the code for the anti-theft system (if installed), see page 69. If the engine is restarted within 15 seconds (time is adjustable with Volvo's service tool, Tech Tool) after having turned it off, the code does not have to be entered again.



#### B Daily maintenance

The user can see daily maintenance items once a day. This screen is dismissed by pressing the ESC button or SELECT button and disappears automatically after 5 seconds if there is no button input.

- Engine oil level
- Coolant level
- Water separator
- Air cleaner
- Hydraulic oil level

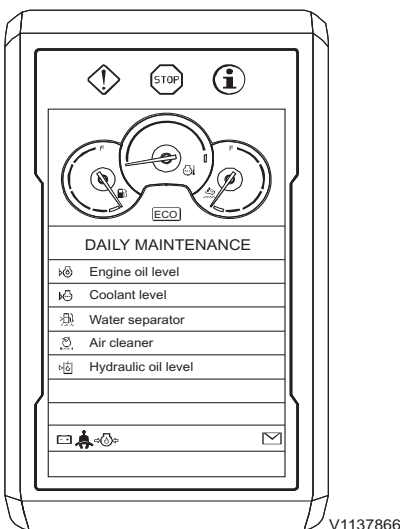

#### C Camera screen (if installed)

All the cameras installed on the machine will be displayed on the IC (Instrument Cluster) when engine is running. The camera screen is dismissed by pressing the ESC button on the keypad.

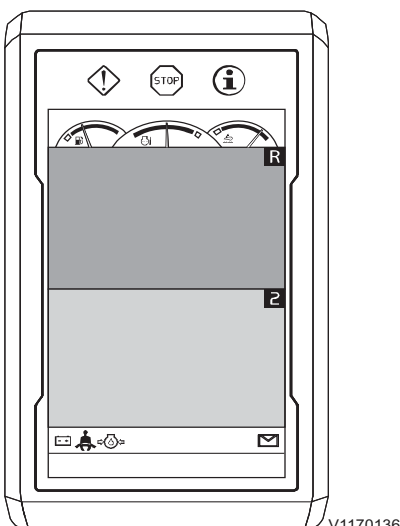

## 44 Instrument panels Display unit

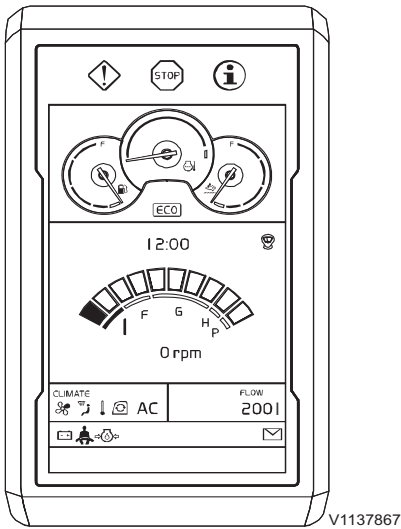

V1137867

### D Main screen

After the camera screen is dismissed, the main screen is displayed.

#### NOTE!

Indicator for seat belt will be displayed for 3 seconds on the "Daily maintenance" screen or main screen. Fasten the seat belt before operating the machine.

#### NOTE!

Camera screen can be shown again

- when camera button is pressed or
- when operating control lever (joystick) / pedal or
- no keypad signal during 10 seconds.

This function is always to check for obstacles or person near the machine. For detailed information about camera control, see page 131.

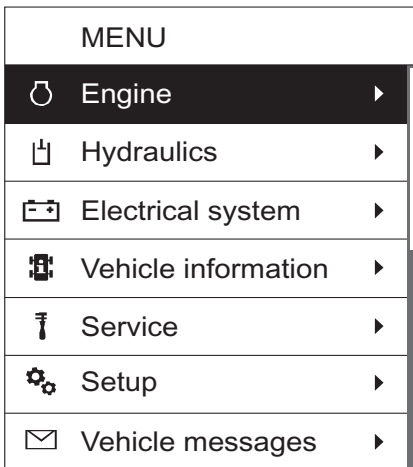

V1137861

### Main menu

The main menu is reached by pressing the SELECT button on the keypad.

Scroll the list by using the arrow buttons on the keypad. When a folder is highlighted, its subscreens are shown when pressing the SELECT button. Use the arrow buttons to scroll between the subscreens. Cancel the action at any time by pressing the ESC button on the keypad.

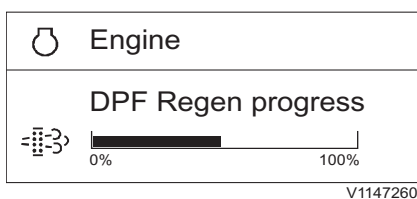
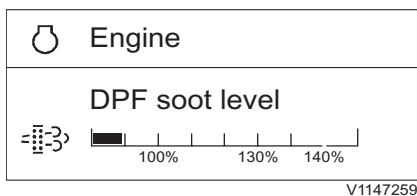
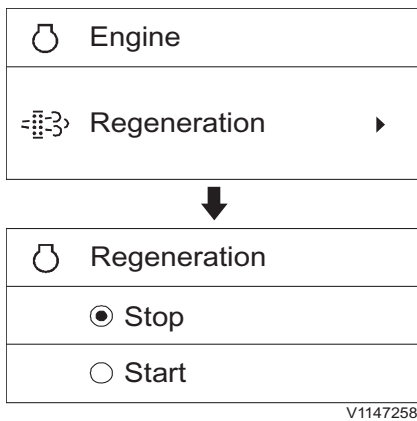
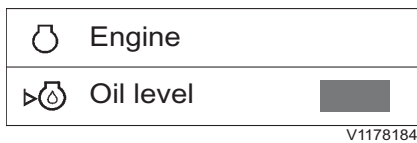
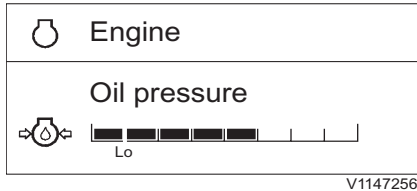

## Subscreens

### 1 Engine

■ **Oil pressure:** This shows the measured value of the engine oil pressure. When the bar graph is green, the value is OK, within normal operation range. When the bar graph is red, the value is abnormal.

■ **Oil level:** This indicator shows the measured value of the engine oil level. The color of the indicator shows the following:

- **Green:** The value is between 30%-100%, the oil level is OK.
- **Yellow:** The value is between 3%-30%, check the oil level with the dipstick at next daily maintenance.
- **Red:** The value is between 0%-3%, the oil level is too low. Check the oil level immediately with the dipstick and take the necessary actions.
- **Grey:** The value is over 100% or system failure. Contact a workshop authorized by Volvo.

■ **Regeneration:** The operator can perform a regeneration with "Start" in the menu when the Diesel Particulate Filter has collected enough soot. When selecting "Stop" in the menu, the regeneration which is in progress will be cancelled. Refer to page 180 for more detailed information.

- Stop
- Start

■ **DPF soot level:** This shows the level of soot that has accumulated within the DPF.

**NOTE!**

Contact a workshop authorized by Volvo for detailed information on the soot level.

■ **DPF Regen progress:** This shows the measured value of DPF regeneration progress. Regeneration is complete when the bar graph reaches 100%.



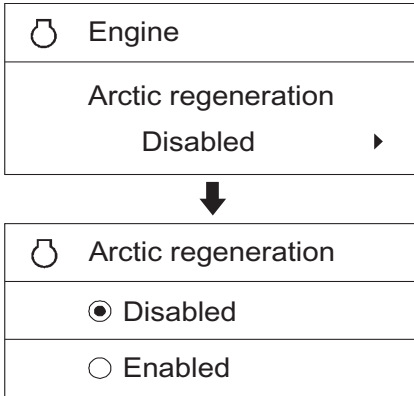

V1147262

- **Arctic regeneration (optional equipment):** Arctic regeneration mode is used for machines that operate in extreme cold climate areas where the machines need to be left running around-the-clock without operator presence. To use this optional mode, the parked regeneration mode should be selected in advance. When selecting "Enabled" in this menu, the parked regeneration is started automatically when needed without any further operator action. This function will only be active while in parked mode, regardless of regeneration mode and will be "Disabled" by default at startup or when leaving the parked mode. This means that the regeneration system can remain in an optimal mode, even after longer periods of idling.

  - Disabled
  - Enabled

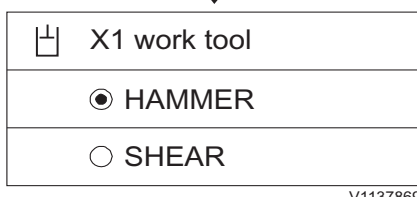
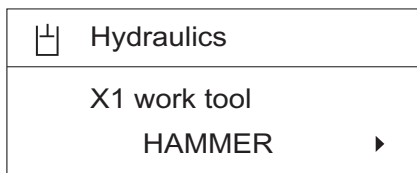
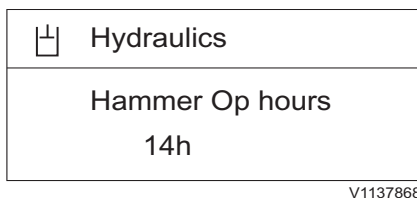
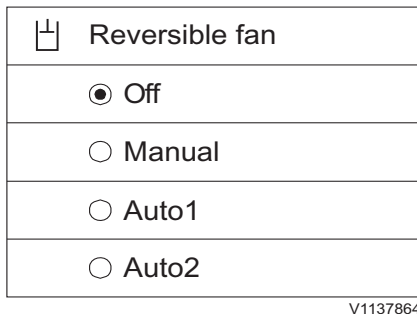
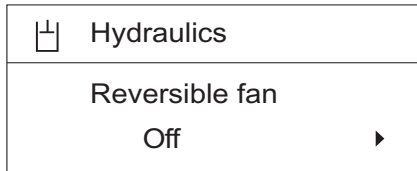
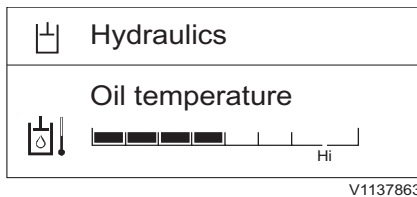

## 2 Hydraulics

■ **Oil temperature:** This shows the measured value of hydraulic oil temperature. When the bar graph is green, the value is OK, within normal operation range. When the bar graph is red, the value is abnormal.

■ **Reversible fan (optional equipment):** This informs the operator which mode is selected at the moment. It also allows the operator to select a reversible fan mode from 4 different modes. The operator can select a reversible fan mode with the arrow buttons. When pressing the SELECT button, the marked mode is set. The screen reverts to the former screen displaying the newly selected mode.

- **Off mode:** Normal rotation or stopping reverse rotation.
- **Manual mode:** Reverses the rotation one cycle immediately after setting the mode.
- **Auto1 mode / Auto2 mode:** Repeats a cycle consisting of normal rotation and reverse rotation.

For more information, see page 219.



■ **Hammer op. hours (optional equipment):** This shows the counted value of hammer operating time in the unit hours and it can not be reset to zero.

### NOTE!

Refer to this "Hammer op. hours" for service interval when replacing the hammer return filter.

■ **X1 work tool (optional equipment):** This informs the operator which tool is selected at the moment. It also allows the operator to select a preset tool showing the name and settings of each tool. When pressing the arrow button, another preset work tool is displayed. When pressing the SELECT button for another tool, the screen reverts the screen to the former screen displaying the name of the newly selected tool.



## 48 Instrument panels Display unit

 Hydraulics
Response mode Active 



 Response mode
<input checked="" type="radio"/> Active
<input type="radio"/> Normal
<input type="radio"/> Soft

V1137871

 Hydraulics
X3 response mode Active 



 X3 response mode
<input checked="" type="radio"/> Active
<input type="radio"/> Normal
<input type="radio"/> Soft

V1137870

■ **Response mode (optional equipment):** This informs the operator which response mode is selected at the moment. It also allows to select a response mode from 3 different modes. The operator can select a response mode from the three modes with the arrow buttons. When pressing the SELECT button, the marked response mode is set. The screen reverts to the former screen displaying the name of the newly selected item.

- Active
- Normal
- Soft

The operator can adjust the movement sensitivity of attachments when operating the levers. "Active" mode is the most sensitive.

■ **X3 response mode (optional equipment):** This informs the operator which X3 response mode is selected at the moment. It also allows to select a response mode from 3 different modes. The operator can select a X3 response mode from the three modes with the arrow buttons. When pressing the SELECT button, the marked response mode is set. The screen reverts to the former screen displaying the name of the newly selected item.

- Active
- Normal
- Soft

The operator can adjust the movement sensitivity of attachments when operating the levers. "Active" mode is the most sensitive.

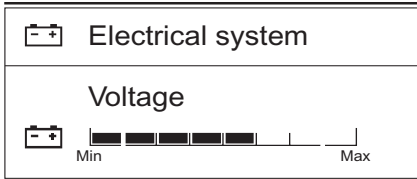

V1137873

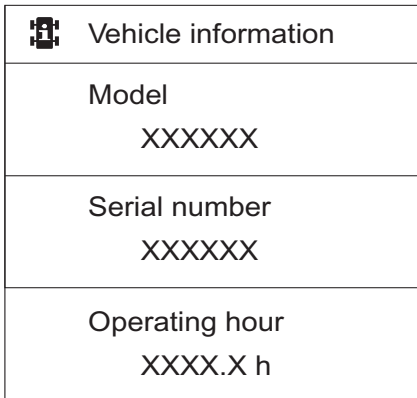

V1168450

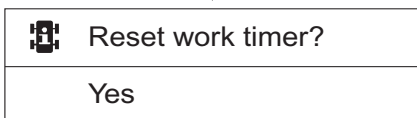
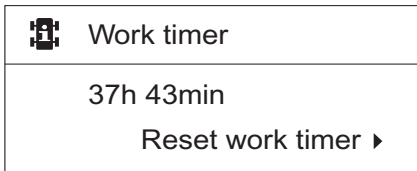
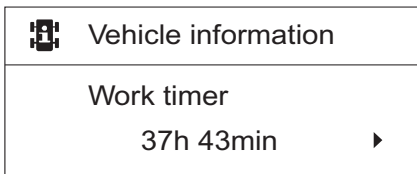

V1140744

### 3 Electrical system

- **Voltage:** This shows the measured value of voltage of the battery. When the bar graph is green, the value is OK, within normal operation range. When the bar graph is red, the value is abnormal.

### 4 Vehicle information

- **Model:** This shows the machine's model name.
- **Serial number:** This shows the machine's serial number.
- **Operating hour:** This shows the machine's operating hours.

- **Work timer:** This shows the counted work time.
  - Reset work timer: Work time can be reset by pressing the SELECT button when the "Work timer" value is highlighted. Press ESC button to "Cancel" or SELECT button to "Yes".

50

Instrument panels  
Display unit

	Vehicle information
Average fuel cons 15 l/h ▶	



	Average fuel cons
Reset fuel cons 15 l/h ▶	



	Reset fuel cons?
Yes	

V1140745

	Vehicle information
Current fuel cons	
	Lo ██████████   Hi
Ambient temperature 25.0 °C	

V1137877

■ **Average fuel cons.:** This shows the calculated average fuel consumption from the last 24 hours.

- Reset fuel cons: Fuel consumption can be reset by pressing the SELECT button when the "Average fuel cons" value is highlighted. Press the ESC button to "Cancel" or SELECT button to "Yes".

■ **Current fuel cons.:** This shows the calculated fuel consumption at the current time.

■ **Ambient temp:** This shows the measured ambient temperature.

## 5 Service

This subscreen shows the service items with "time remaining" value. Press the SELECT button to adjust interval or to check detail information.

### ■ Engine oil/filter

- Interval: This shows the value of engine oil/filter interval in the unit hours. According to engine oil/filter type, the operator can adjust engine oil/filter interval. The setting range is 50 ~ 500 hours.

🔑 Service
Engine oil/filter 450h ▶



🔑 Engine oil/filter
Interval: 500h Set interval ▶



🔑 Engine oil/filter
Set interval: ◆ 500h

V1137878

🔑 Engine oil/filter
Time remaining: 450h Reset time remain ▶

V1137879

🔑 Reset time remaining?
Yes

V1140746

- Time remaining: This shows the value for remaining time to next engine oil/filter service. When the "Time remaining" reaches 40 h, 20 h, and 0 h, the check screen with "Time remaining" and "Interval" will pop up on the IC (Instrument Cluster). Service the maintenance items which should be serviced in that interval. For the service interval and maintenance items, see page 359.
- Reset time remaining?: After servicing the maintenance items, the time can be reset. Press ESC button to "Cancel" or SELECT button to "Yes". When the time is reset, the next service interval and "Time remaining" will be displayed.  
If the operator does not replace the engine oil/filter and resets this value, it turns to zero and then to negative.

## 52 Instrument panels Display unit

 Service
Fuel filter/Water sep 450h ▶



 Fuel filter/Water sep
Interval: 500h Set interval ▶



 Fuel filter/Water sep
Set interval: ◆ 500h

V1137881

 Fuel filter/Water sep
Time remaining: 450h Reset time remain ▶

V1137882

 Reset time remaining?
Yes

V1140746

### ■ Fuel filter/Water sep

- Interval: This shows the value of fuel filter/ water separator interval with in the unit hours. The operator can adjust fuel filter/water separator interval. The setting range is 50 ~ 500 hours.

- Time remaining: This shows the value for remaining time for next fuel filter/water separator service. When the "Time remaining" reaches 40 h, 20 h, and 0 h, the check screen with "Time remaining" and "Interval" will pop up on the IC (Instrument Cluster). Service the maintenance items which should be serviced in that interval. For the service interval and maintenance items, see page 359.
- Reset time remaining?: After servicing the maintenance items, the time can be reset. Press ESC button to "Cancel " or SELECT button to "Yes". When the time is reset, the next service interval and "Time remaining" will be displayed. If operator does not maintain the parts and reset this value it turns to zero and then to negative.

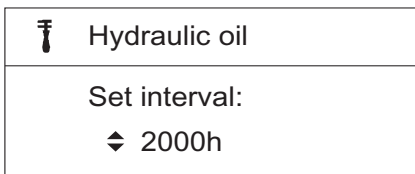
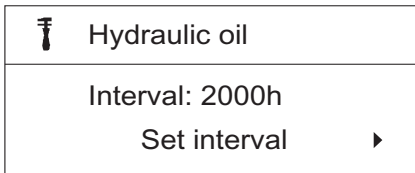
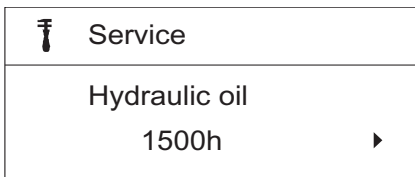

V1137883

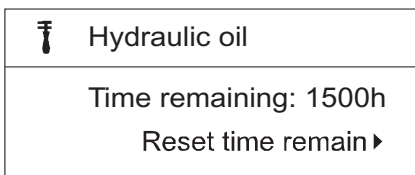

V1137884

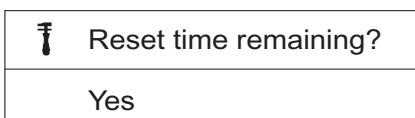

V1140746

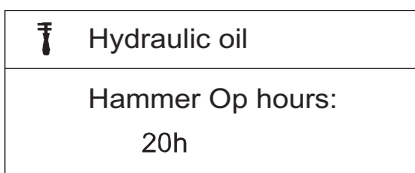

V1137885

### ■ Hydraulic oil

- Interval: This shows the value of hydraulic oil interval in the unit hours. The operator can adjust the hydraulic oil interval. The setting range is 100 ~ 5000 hours.

- Time remaining: This shows the value for remaining time to next hydraulic oil service. When the "Time remaining" reaches 40 h, 20 h, and 0 h, the check screen with "Time remaining" and "Interval" will pop up on the IC (Instrument Cluster). Service the maintenance items which should be serviced in that interval. For the service interval and maintenance items, see page 359.

- Reset time remaining?: After servicing the maintenance items, the time can be reset. Press ESC button to "Cancel " or SELECT button to "Yes". When the time is reset, the next service interval and "Time remaining" will be displayed.

If operator does not maintain the parts and reset this value it turns to zero and then to negative.

- Hammer op. hours: This shows the counted value of hammer operating time in the unit hours. "Hammer op. hours" is not adjustable. It is automatically reset to zero when "Time remaining" is reset and shows the hammer operating hours from the reset point.



## 54 Instrument panels Display unit

 Service
Hydraulic oil filter 1500h ▶



 Hydraulic oil filter
Interval: 2000h Set interval ▶



 Hydraulic oil filter
Set interval: ◆ 2000h

V1137886

 Hydraulic oil filter
Time remaining: 1500h Reset time remain ▶

V1137887

 Reset time remaining?
Yes

V1140746

 Hydraulic oil filter
Hammer Op hours: 20h

V1137888

### ■ Hydraulic oil filter

- Interval: This shows the value of hydraulic oil filter interval in the unit hours. The operator can adjust the hydraulic oil filter interval. The setting range is 100 ~ 2000 hours.

- Time remaining: This shows the value for remaining time to next hydraulic oil filter service. When the "Time remaining" reaches 40 h, 20 h, and 0 h, the check screen with "Time remaining" and "Interval" will pop up on the IC (Instrument Cluster). Service the maintenance items which should be serviced in that interval. For the service interval and maintenance items, see page 359.

- Reset time remaining?: After servicing the maintenance items, the time can be reset. Press ESC button to "Cancel " or SELECT button to "Yes". When the time is reset, the next service interval and "Time remaining" will be displayed.

If operator does not maintain the part and reset this value it turns to zero and then to negative.

- Hammer op. hours: This shows the counted value of hammer operating time in the unit hours. "Hammer op. hours" is not adjustable. It is automatically reset to zero when "Time remaining" is reset and shows the hammer operating hours from the reset point.

## 6 Setup

There are sub-items, "X1 work tool", "X3 Operation", "Auto idle time", "Anti-theft system", "Joystick shortkey", "Language", "Units", "Time/date", "Display light", and "Keypad backlight".

### ■ X1 work tool

This is to preset the X1 setting so that operators can use it simply by selecting the tool from the list.

**Enter password:** Enter the password to proceed with the setting for X1 tools. The password screen is displayed whenever the password is set using Volvo's service tool.

There are 3 sub-items which are,

- New
- Change
- Delete

Use the arrow buttons to place the cursor (highlighting bar) on the required item, and then press the SELECT button.

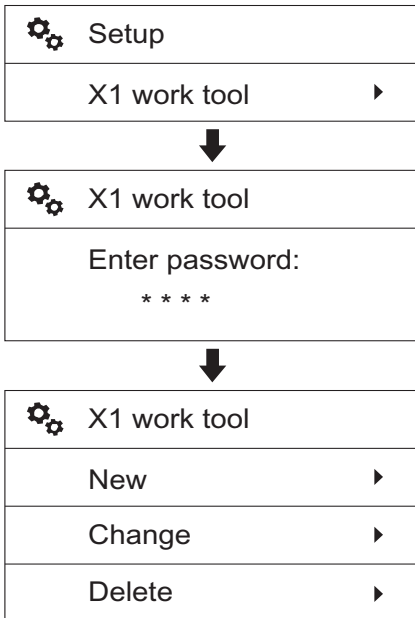

V1137889

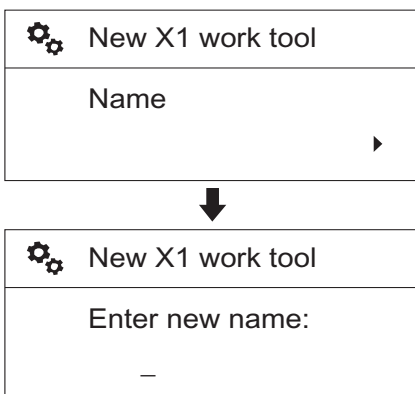

V1137890

### New

The New setting is used to add new X1 tools. Follow the steps from 1 through 8, described below, to set and "Save" the parameters for the new attachment.

### NOTE!

If the "Save" procedure described in 8 is not performed, all settings are cancelled automatically.

- 1 Select "New" after entering "X1 work tool".
- 2 Name: Enter the name of the tool.
  - Use the arrow UP and arrow DOWN button to select the characters (A,B...Z,0,1...9).
  - Use the SELECT button to enter the selected character.
  - Press the SELECT button once again to save the name.
  - Use the ESC button to delete the entered character.

	New X1 work tool
Flow	280 l



	New X1 work tool
Set flow:	◆ 280 l

V1137891

	New X1 work tool
Pressure	220 bar



	New X1 work tool
Set pressure:	◆ 220 bar

V1137892

	New X1 work tool
Control	Push



	New X1 work tool
<input checked="" type="radio"/>	Push
<input type="radio"/>	Toggle
<input type="radio"/>	Proportional

V1137893

- 3 Flow: Set the flow rate when this optional function is selected.
  - Select the preferred flow rate value using the arrow buttons.
  - Save the selected value using the SELECT button. Use the ESC button to cancel without saving.

- 4 Pressure: Set the pressure when this optional function is selected.
  - Select the preferred pressure value using the arrow buttons.
  - Save the selected value using the SELECT button. Use the ESC button to cancel without saving.

- 5 Control: Choose the control type.
  - Select the preferred control type using the arrow buttons.
  - Save the selected item using the SELECT button. Use ESC button to cancel without saving.

For information on control types, see page 78.

  - Push
  - Toggle
  - Proportional



 New X1 work tool
Pedal control Push ▶



 New X1 work tool
<input checked="" type="radio"/> Push
<input type="radio"/> Toggle
<input type="radio"/> Proportional

V1137894

 New X1 work tool
Attachment 1 way ▶



 New X1 work tool
<input checked="" type="radio"/> 1 way
<input type="radio"/> 2 way

V1137895

 New X1 work tool
Save

V1137896

- 6 Pedal control: Choose the pedal control type.
- Select the preferred control type using the arrow buttons.
  - Save the selected item using the SELECT button. Use ESC button to cancel without saving.

For information on control types, see page 78.

- Push
- Toggle
- Proportional

- 7 Attachment: Choose the 1 way or 2 way control.
- Select the preferred setting using the arrow buttons.
  - Save the selected item using the SELECT button. Use ESC button to cancel without saving.



- 8 Save: Save the setting.
- Select "Save" and press the SELECT button to save all settings including "Name", "Flow", "Pressure", "Control", "Pedal control", and "Attachment".

**NOTE!**

After entering the new settings, the "Save" procedure should be performed to record the new parameters in the system memory. If the "Save" procedure is not performed, all the settings will be cancelled automatically.

- If some items are not set up, the error message "Fill out all items" will appear.



- 9 The added X1 tool is newly listed.

 X1 work tool
Change 



 Change X1 work tool
<input type="radio"/> HAMMER
<input type="radio"/> SHEAR
<input checked="" type="radio"/> VOLVO

V1137897

 X1 work tool
Delete 



 Delete X1 work tool
<input checked="" type="radio"/> VOLVO



 Are you sure to delete?
Yes

V1140747

### Change

This is to modify the setting of preset X1 tools.

- 1 Select "Change" after entering "X1 work tool".
- 2 Select the tool to be modified using the arrow buttons and press the SELECT button.
- 3 Follow the same procedures from 2 to 8 explained in "New" section described above to change the setting.
- 4 There are some restrictions when modifying the setting:
  - The "Name" of two default X1 tools "HAMMER" and "SHEAR" are not modifiable.
  - The "HAMMER" can not be "2-way".
- 5 The modified X1 tool is listed.

### Delete

Use the arrow buttons to place the cursor (highlighting bar) on the required item, and then press the SELECT button.

To delete the preset "X1 work tool", proceed as follows :

- 1 Select "Delete" after entering "X1 work tool".
- 2 Select the tool to delete using the arrow buttons and press the SELECT button.

### NOTE!

Current preset X1 tool and default tools are not displayed.

- 3 Are you sure to delete?: Confirming message is displayed on the screen, press SELECT button to "Yes" or ESC button to "Cancel".

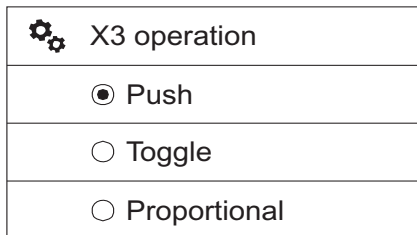
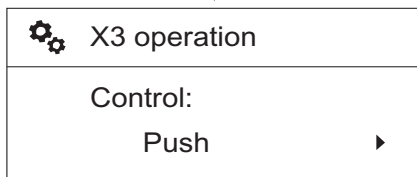
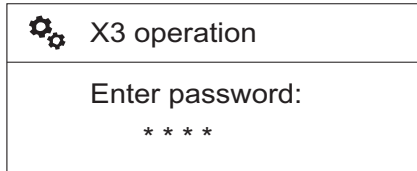
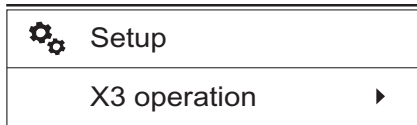

V1140748

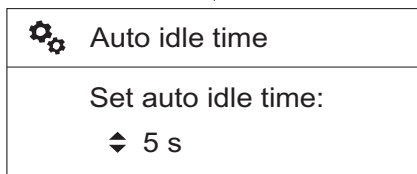
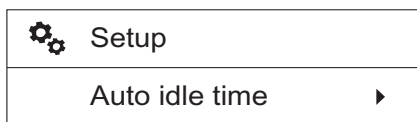

V1137900

### ■ X3 Operation

**Enter password:** Enter the password to proceed with the setting for X3 tools. The password screen is displayed whenever the password is set using Volvo's service tool.

Place the mark at the preferred item from the three listed with the arrow button.

When the SELECT button is pressed, the marked item is set. The screen reverts to the former screen displaying the newly selected item.

Refer to page 78 for more detailed information on control types.

### ■ Auto idle time

The basic concept of "Auto idle" is to reduce fuel consumption. The engine rpm will be lowered automatically to idle mode, if the Auto idle button is ON and any of control levers (pedals) or engine speed control switch are not operated for a certain time.

The operator can set Auto idle time from 3 seconds to 20 seconds.

■ **Anti-theft system:** See page 69 for information.

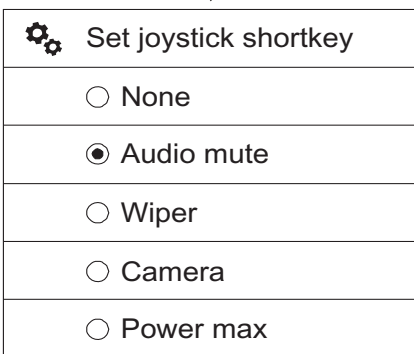
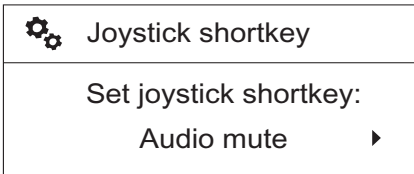
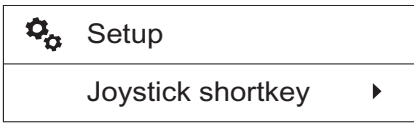

V1137902

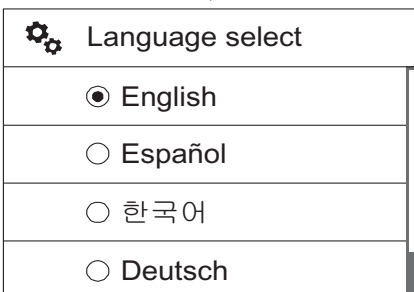
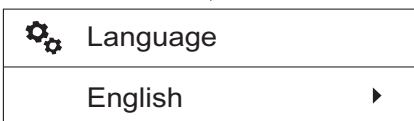
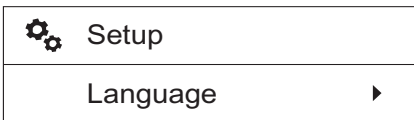

V1137903

- **Joystick shortcut:** Operator can use a function easily with a button of the left control lever. See page 94 for the position of the button. It also allows selection of a function from 5 different functions. The operator can select a function from 5 different functions with the arrow buttons. When pressing the SELECT button, the marked function is set. The screen reverts to the former screen displaying the name of the newly selected item. Also the selected item is displayed with a symbol on the IC (Instrument Cluster).

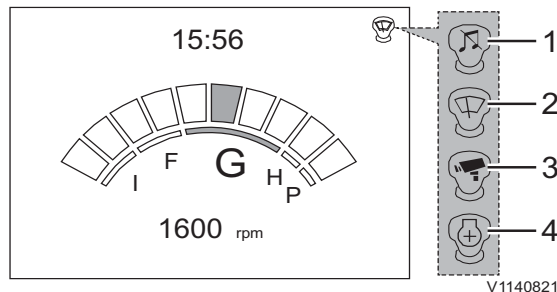

V1140821

- 1 Audio mute
- 2 Wiper
- 3 Camera
- 4 Power max

■ **Language**

Supported languages are listed in the screen in the form of their own languages. Use the arrow buttons to scroll up and down to find your specific language. Press the SELECT button to select the chosen language. The screen reverts to the former screen displaying the newly selected language.

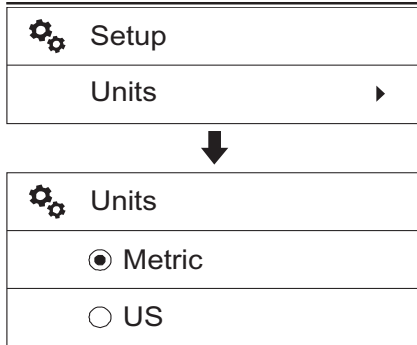

V1137904

■ Units

Two unit systems are displayed: "Metric" and "US". The operator can select one of the two using the arrow button and save it by pressing SELECT button.

The units stored in the IC (Instrument Cluster) are as follows;

Item	Metric	US
Time	h	h
Fluid rate	l/h	g/h
Volume	L	G
Voltage	V	V
Current	A	A
Temperature	°C	°F
Revolution	rpm	rpm
Speed	km/h	mph
Pressure	bar	psi
Distance	km	mile



 Setup
Time/date ▶



 Time/date
Date set 20140101 ▶



 Set date
yyymmdd: ◆ 20140101

V1137905

 Time/date
Time set 12:30 ▶



 Set time
24h: ◆ 12:30

V1137906

 Time/date
Date format yyymmdd ▶



 Date format
<input checked="" type="radio"/> yyymmdd
<input type="radio"/> mmddyyyy
<input type="radio"/> ddmmyyyy

V1137907

■ Time/Date

- Date set: This is for adjusting the date. The preset date format is shown in the first row of the screen. The operator can adjust the date with arrow, ESC, and SELECT buttons. SELECT and ESC buttons are used to move ahead or go back with the cursor. Arrow buttons are used to adjust each segment of the date.

- Time set: This is for adjusting the time. The preset clock format is shown in the first row of the screen. The operator can adjust the time with arrow, ESC, and SELECT buttons. SELECT and ESC buttons are used move ahead or go back with the cursor. Arrow buttons are used to adjust each segment of the time.

- Date format: The items "yyymmdd", "mmddyyyy", and "ddmmyyyy" decide how the IC (Instrument Cluster) shows the date. "yyyy" means year, "mm" means month, and "dd" means day.

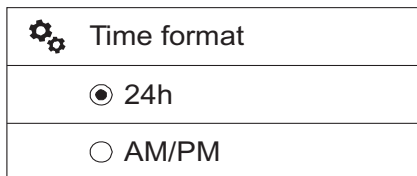
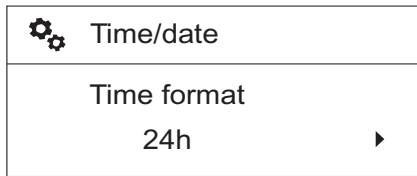

V1137908

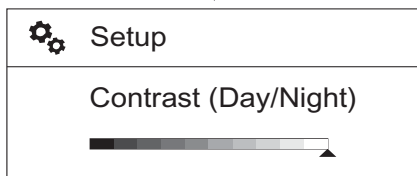
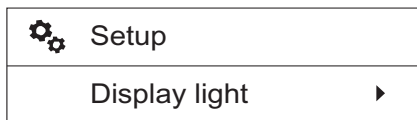

V1137909

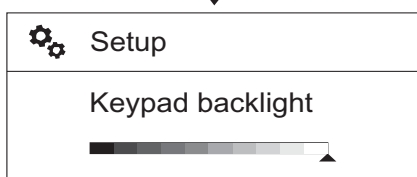
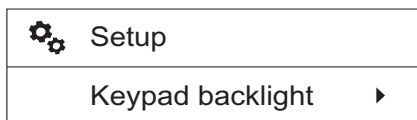

V1137910

- Time format: The items "24h" and "AM/PM" decide how the IC (Instrument Cluster) describes the time, 24-hour-system or 12-hour-system.

#### ■ Display light

This is for changing the contrast of the IC (Instrument Cluster). The adjusting bar in the screen is controlled with the arrow buttons and the value is set with the SELECT button. The contrast is independently adjustable for day and night.

##### Contrast (Day/Night)

- When adjusting the "Contrast(Day)", the machine's work lights should be turned off.
- When adjusting the "Contrast(Night)", the machine's work lights should be turned on.

#### ■ Keypad backlight

The brightness of the keypad backlight is changed by the adjustment. The adjusting bar in the screen is controlled with the arrow buttons and the value is set with the SELECT button.



## 64 Instrument panels Display unit

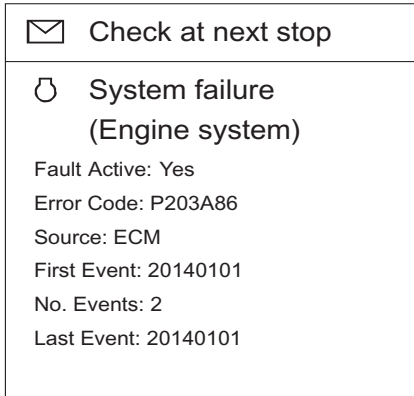
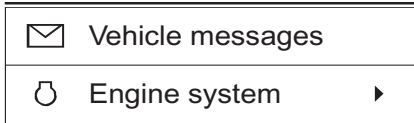

V1137911

### 7 Vehicle messages

This shows the headlines of messages. There are no errors or warning messages in normal operation.

If an abnormal condition is sensed, then the message will display the specific error/failure. Contact a workshop authorized by Volvo for advice, if needed.

When pressing the SELECT button to view detail information about a headline, the displayed information replaces the whole "main screen".

The information content includes;

- Fault Active
- Error Code
- Source
- First Event
- No. of events
- Last event

## Alarm texts

The information to the operator is provided on the display unit in the form of alarm texts, which are divided into three classes: Warning, Check and Information.

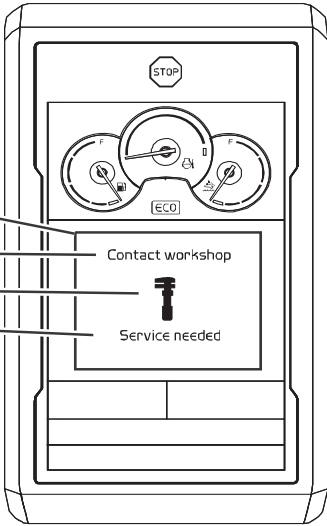
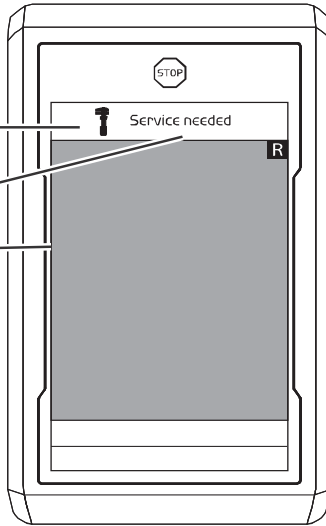
 <b>Warning (red)</b> <small>V1161686</small>		
Alarm in main screen	Alarm in camera screen	
 <p style="text-align: right;"><small>V1208575</small></p>	 <p style="text-align: right;"><small>V1208576</small></p>	<ul style="list-style-type: none"> <li>- This screen is to warn the operator when the electronic system senses a machine malfunction or a safety related failure.</li> <li>- The red central warning symbol is shown.</li> <li>- The buzzer will sound until the required action has been performed.</li> <li>- The alarm text will be shown until the required action has been performed.</li> <li>- <b>Check the alarm text in a red box for the alarm reason and the required action.</b></li> <li>- Very time critical information/high priority or safety-related procedure. Immediate action needed.               <ol style="list-style-type: none"> <li>1 Stop the machine or operate equipment in a safe way as soon as possible.</li> <li>2 Perform a requested action before any operation.</li> <li>3 Turn off the engine if required.</li> </ol> </li> <li>- <b>Repair if possible or contact a qualified service technician.</b></li> </ul>
<p>A Information box (red)            B Text area for action            C Symbol area (red)            D Text area for reason or detail information            E Camera screen</p>		



Check (amber)

V1161687

Alarm in main screen	Alarm in camera screen	
<p>V1208573</p>	<p>V1208574</p>	<ul style="list-style-type: none"> <li>- This screen is to inform the operator when a partial failure of the machine is detected.</li> <li>- The amber central caution symbol is shown.</li> <li>- The buzzer sounds four times.</li> <li>- Press SELECT button to obtain more information about the malfunction.</li> <li>- Alarm text is shown until confirmation is performed by pressing ESC button.</li> <li>- <b>Check the alarm text in a amber box for the alarm reason and the required action.</b></li> <li>- Medium time critical information/ medium priority.</li> <li>- Need to be attention and/or further monitoring required but it is not necessary to stop the machine immediately.</li> <li>- <b>Check the machine before next operation. Repair if possible or contact a qualified service technician.</b></li> </ul>
<p>A Information box (amber)                  B Text area for action                  C Symbol area (amber)                  D Text area for reason or detail information                  E Camera screen</p>		



Information (blue)

V1161688

Alarm in main screen

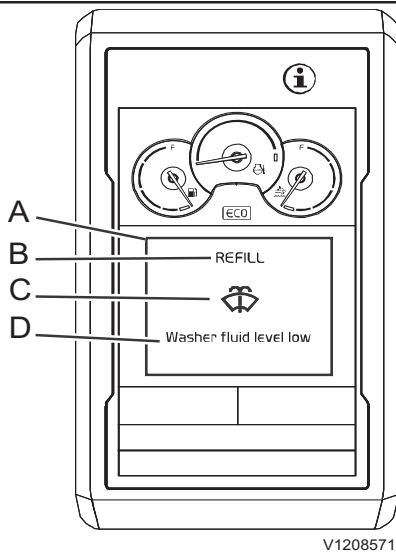

V1208571

Alarm in camera screen

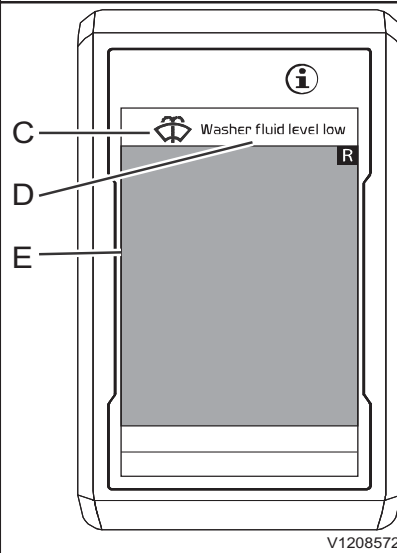

V1208572

- A Information box (blue)
- B Text area for action
- C Symbol area (blue)
- D Text area for reason or detail information
- E Camera screen

- This screen is to give useful information about the machine.
- The blue central information symbol is shown.
- The buzzer sounds two times.
- The alarm text is shown for eight seconds and then changes to operating display or can be hidden immediately by pressing ESC button.
- **Check the alarm text in a blue box for the alarm reason and the required action.**
- Low time critical information/low priority.
- Need to be alerted, but active attention or system monitoring is not required.
- **Check the machine before next operation. Repair if possible or contact a qualified service technician.**

68 Instrument panels  
Display unit

Result (white) / Function description (green)		
Alarm in main screen	Alarm in camera screen	<b>Result</b>
<p>V1208577</p>	<p>V1208578</p>	<ul style="list-style-type: none"> <li>- Non-time critical information.</li> <li>- Presentation of result from selected action by operator.</li> <li>- Symbol and text message in a white box for result.</li> </ul>
<p><b>Function description</b></p> <ul style="list-style-type: none"> <li>- Can be used to provide help for the operator on activated functions.</li> <li>- Should be possible to activate/deactivate to avoid unnecessary disturbance for operator not requiring this.</li> <li>- Symbol and text message in a green box for function description.</li> </ul>		
<p>A Information box (white or green)                  B Symbol area (optional) (white or green)                  C Text area for result/function description (white or green)                  D Camera screen</p>		

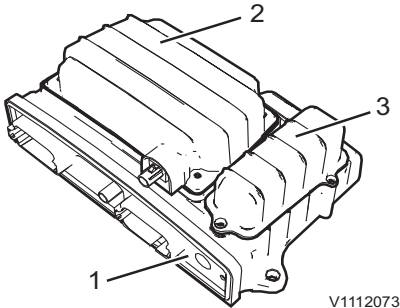

CareTrack unit

- 1 WECU
- 2 Satellite modem
- 3 Back-up battery

## CareTrack with anti-theft

### CareTrack with anti-theft (optional equipment)

CareTrack with anti-theft function works by WECU, web portal, Volvo's service tool (Tech Tool), GPMECU1, and IC (Instrument Cluster). The anti-theft function is to immobilize the machine according to the following conditions.

- Wrong code alarm
- Geofence broken
- Timefence broken
- System tampered
- Machine movement
- Battery power lost
- Remote immobilization
- No coverage
- ECU tampered

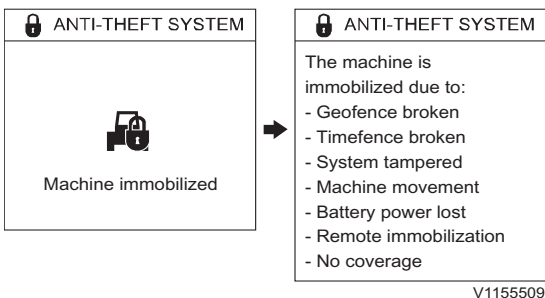

### Machine immobilized information

This screen is to warn the operator when the machine is immobilized. To get more information about the message on the screen, press the SELECT button. To go back to the previous screen, press the ESC button.

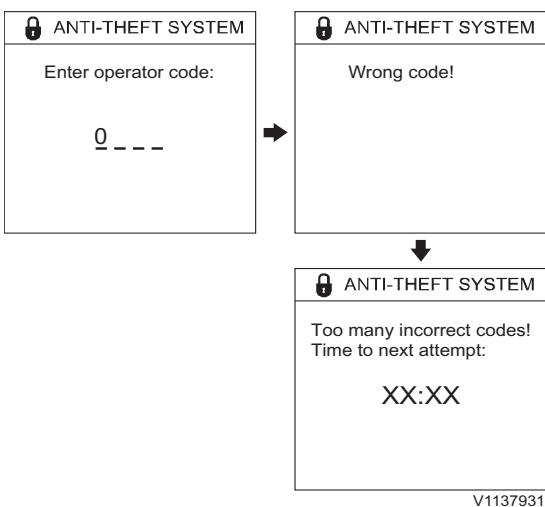

### Wrong code alarm

- When the machine is turned on, the authorization code display is shown if the anti-theft system is selected as an optional equipment. Wrong code display appears on the IC when the operator or machine owner has entered the wrong code. After 3 inputs of an incorrect code, the authorization will be limited for 5 minutes and a wrong code alarm will send to the CareTrack portal. The default code lock's delay time is 2 minutes and it can be changed with Volvo's service tool.

- Enter operator code
- Wrong code
- Too many incorrect codes
- Time to next attempt



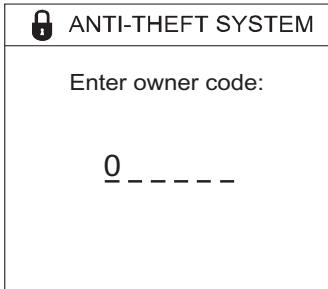

V1137932

Enter owner code

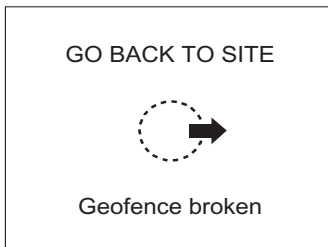

V1137933

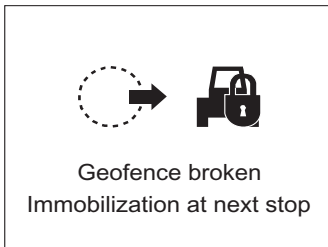

V1137934

**NOTE!**

When the delay time is shown, press and hold the SELECT button to enter the owner code.

- There are 3 levels for authorizing machine operation.
  - Level 1: This is the operator code with 4 digits which are set by the machine owner in IC menu or CareTrack portal.
  - Level 2: This is a machine owner PIN code with 6 digits which are set using Volvo's service tool.
  - Level 3: This is a one-time code with 8 digits which are obtained from the CareTrack portal.

**Geofence broken**

- When the machine owner activates a geofence in the CareTrack portal and the machine is outside the geofence, the geofence broken message will appear on the IC.

- When the machine owner activates a geofence and configures automatic immobilization in the CareTrack portal and the machine is outside the geofence, the geofence broken warning message will appear on the IC and the machine is immobilized at the next stop.
- WECU sends the warning message to the CareTrack portal.
- The warning condition is revoked when the machine is inside the geofence.

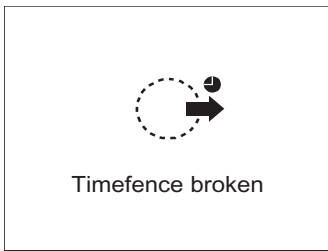

V1137935

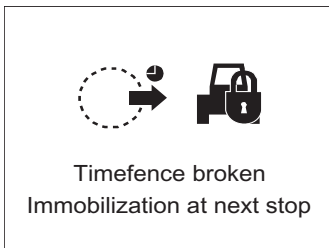

V1137936

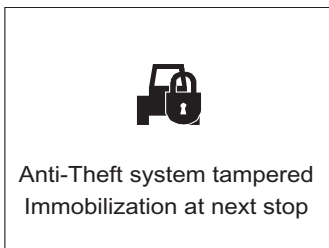

V1155538

### Timefence broken

- When the machine owner activates a timefence in the CareTrack portal and the machine is outside the timefence, the timefence broken message appears on the IC.

- When the machine owner activates a timefence and configures automatic immobilization in the CareTrack portal and the machine is outside the timefence, the timefence broken warning message appears on the IC and the machine is immobilized at the next stop.
- WECU sends the warning message to the CareTrack portal.
- The warning condition is revoked when the machine is inside the timefence.

### System tampered

#### ■ GPS tampered

- If the machine lost GPS antenna cable connection, the GPMECU1 informs the operator with the warning message on the IC and activates machine immobilization.

#### ■ GSM/3G tampered

- If someone cuts the GSM/3G antenna, the GPMECU1 informs the operator with the warning message on the IC and activates machine immobilization.

#### ■ Open box detection

- If someone tries to open the WECU enclosure, the GPMECU1 informs the operator with the warning message on the IC and activates machine immobilization.

#### ■ SIM card tampered

- If someone removes or changes the SIM card, the GPMECU1 informs the operator with the warning message on the IC and activates machine immobilization.

### NOTE!

WECU sends the warning message to the CareTrack portal.

## 72 Instrument panels Display unit



V1139556

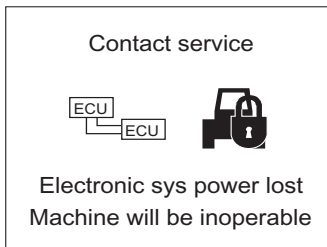

V1137938

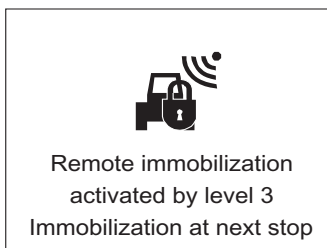

V1137939



V1137940

### Machine movement

- If the machine moves 100 metres without its own power, the WECU detects the machine movement and the machine will be immobilized and WECU sends the warning message to the CareTrack portal.
- After the machine has been immobilized, the warning message will appear on the IC before the authorization code display.
- The machine owner or dealer can mobilize (de-immobilize) the machine with codes for Level 2 and Level 3.

### Battery power lost

- If the WECU is disconnected from battery power cable or detects the battery supply voltage lower than 8 V, the WECU operates on its own internal battery.
- The GPMECU1 activates machine immobilization and the red warning message will appear on the IC.
- WECU sends the warning message to the CareTrack portal.
- The warning condition is revoked when the trigger has disappeared.

### Remote immobilization

- If dealer (level 3 code owner) requests machine immobilization in the CareTrack portal, the remote immobilization warning message will appear on the IC and the machine is immobilized at the next stop.
- If machine owner requests machine immobilization in the CareTrack portal, the remote immobilization warning message will appear on the IC and the machine is immobilized at the next stop.

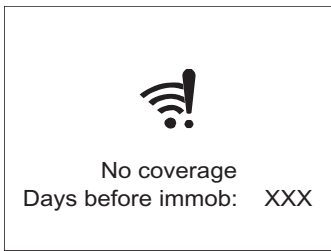

V1139554



V1137942

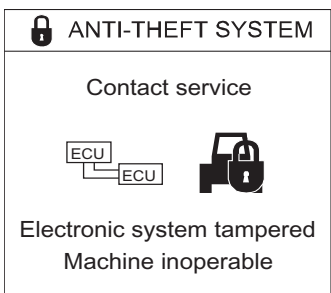

V1139558



V1155510

### No coverage

- If the WECU has not been connected to the CareTrack portal for the number of days set by Volvo's service tool, the machine will be immobilized.
- The no coverage days warning will appear at every start with number of remaining days set by Volvo's service tool.
- The active trigger and no coverage counter can be reset using a one-time code or Volvo's service tool.
- If the machine gets a connection to the CareTrack portal, the machine will be mobilized (de-immobilized) and the coverage counter is reset.

### ECU tampered

- When the machine is turned on, the WECU and GPMECU1 check the machine serial number of the other ECUs. If the machine's serial number is different, the GPMECU1 prevents machine start immediately and a warning message will appear on the IC.
- If the WECU is disconnected from key on cable and the machine is turned on, the GPMECU1 prevents machine start immediately and a warning message will appear on the IC.
- The warning condition is revoked when the trigger has disappeared.

## 74 Instrument panels Display unit

### Anti-theft system, setup menu

This menu is used for setting up the anti-theft system. This menu is divided into two sub-menus as follows.

- 1 **Pin-code menu:** The machine owner's PIN code is required to access this menu. (6 digits)

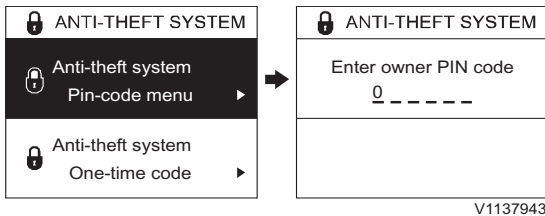

#### Enter owner PIN code

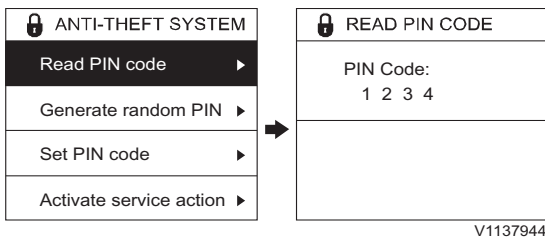

- **Read PIN code:** This sub-menu allows the machine owner to read the current PIN code. (4 digits)

#### PIN Code

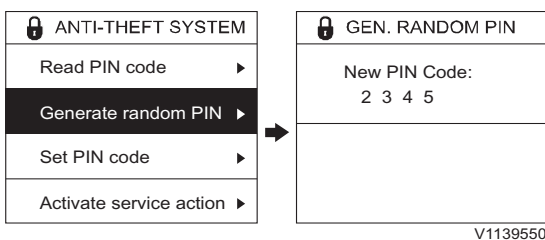

- **Generate random PIN:** This sub-menu allows the machine owner to generate a random PIN code. (4 digits)

#### New PIN Code

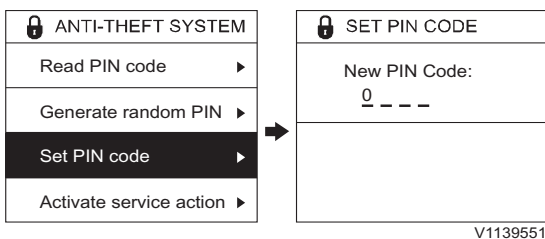

- **Set PIN code:** This sub-menu allows the machine owner to set a preferred PIN code. (4 digits)

#### New PIN Code

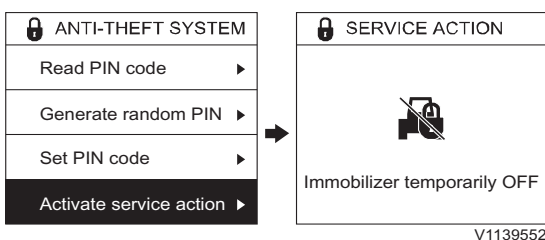

#### Immobilizer temporarily OFF

- **Activate service action:** This sub-menu is used for activating service actions such as moving the machine, replacing the machine battery and disconnecting the GPS antenna. This disables the anti-theft system except for remote immobilization, no coverage immobilization and machine serial number check, and the WECU informs the CareTrack portal. The anti-theft system will be activated when the ignition is turned on the next time.

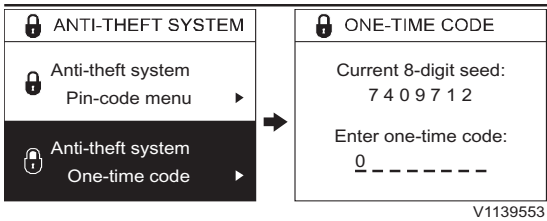

V1139553

Current 8-digit seed  
Enter one-time code

**2 One-time code:** This is used for setting a one-time code when the machine is immobilized with level 3 remote immobilization or no coverage warning condition.  
The machine owner gets the one-time code from the dealer. The dealer gets an 8-digit random code in the CareTrack portal with 8-digit seed (number shown on IC) and machine serial number.

### Alarm texts for anti-theft system







#### Information

- The blue information symbol is shown.
- The buzzer sounds two times.
- Alarm text is shown for seven seconds and then changes to operating display.

<p>GO BACK TO SITE</p> <p>Geofence broken</p> <p>V1137933</p>	<p>Timefence broken</p> <p>V1137935</p>	
<p>Go back to site Geofence broken</p>	<p>Timefence broken</p>	

**Check**







- The amber central warning symbol is shown.
- The buzzer sounds four times.
- Press SELECT button to obtain more information about the malfunction.
- Alarm text is shown until confirmation is performed by pressing ESC button.
- Repair or contact a workshop authorized by Volvo for information.

<div style="border: 1px solid black; padding: 10px; text-align: center;">  <p>Geofence broken Immobilization at next stop</p> <p style="font-size: small;">V1137934</p> </div> <p>Geofence broken Immobilization at next stop</p>	<div style="border: 1px solid black; padding: 10px; text-align: center;">  <p>Timefence broken Immobilization at next stop</p> <p style="font-size: small;">V1137936</p> </div> <p>Timefence broken Immobilization at next stop</p>	<div style="border: 1px solid black; padding: 10px; text-align: center;">  <p>Anti-Theft system tampered Immobilization at next stop</p> <p style="font-size: small;">V1155538</p> </div> <p>Anti-Theft system tampered Immobilization at next stop</p>
<div style="border: 1px solid black; padding: 10px; text-align: center;">  <p>No coverage Days before immob: XXX</p> <p style="font-size: small;">V1139554</p> </div> <p>No coverage Days before immob</p>	<div style="border: 1px solid black; padding: 10px; text-align: center;">  <p>No coverage Immobilization at next stop</p> <p style="font-size: small;">V1137942</p> </div> <p>No coverage Immobilization at next stop</p>	<div style="border: 1px solid black; padding: 10px; text-align: center;">  <p>Remote immobilization activated by level 3 Immobilization at next stop</p> <p style="font-size: small;">V1137939</p> </div> <p>Remote immobilization activated by level 3 Immobilization at next stop</p>
<div style="border: 1px solid black; padding: 10px; text-align: center;">  <p>Remote immobilization activated by owner Immobilization at next stop</p> <p style="font-size: small;">V1137940</p> </div> <p>Remote immobilization activated by owner Immobilization at next stop</p>		



**Warning**

- The red central warning symbol is shown.
- The buzzer will sound until the required action has been performed.
- The alarm text will be shown until the required action has been performed.
- Repair or contact a workshop authorized by Volvo for information.

<p> ANTI-THEFT SYSTEM</p> <div style="border: 1px solid black; padding: 10px; text-align: center;">               Machine immobilized  <small>V1139556</small> </div> <p>Machine immobilized</p>	<p> ANTI-THEFT SYSTEM</p> <div style="border: 1px solid black; padding: 10px;"> <p>The machine is immobilized due to:</p> <ul style="list-style-type: none"> <li>- Geofence broken</li> <li>- Timefence broken</li> <li>- System tampered</li> <li>- Machine movement</li> <li>- Battery power lost</li> <li>- Remote immobilization</li> <li>- No coverage</li> </ul> </div> <p style="text-align: right;"><small>V1155511</small></p> <ul style="list-style-type: none"> <li>- Geofence broken</li> <li>- Timefence broken</li> <li>- System tampered</li> <li>- Machine movement</li> <li>- Battery power lost</li> <li>- Remote immobilization</li> <li>- No coverage</li> </ul>	<p> ANTI-THEFT SYSTEM</p> <div style="border: 1px solid black; padding: 10px; text-align: center;"> <p>Contact service</p> <div style="display: flex; justify-content: center; align-items: center;">   </div> <p>Electronic system tampered Machine inoperable</p> </div> <p style="text-align: right;"><small>V1139558</small></p> <p>Contact service Electronic system tampered Machine inoperable</p>
<p> ANTI-THEFT SYSTEM</p> <div style="border: 1px solid black; padding: 10px; text-align: center;"> <p>Contact service</p> <div style="display: flex; justify-content: center; align-items: center;">  </div> <p>Anti-Theft system tampered Machine immobilized</p> </div> <p style="text-align: right;"><small>V1155510</small></p> <p>Contact service Anti-Theft system tampered Machine immobilized</p>	<div style="border: 1px solid black; padding: 10px; text-align: center;"> <p>Contact service</p> <div style="display: flex; justify-content: center; align-items: center;">   </div> <p>Electronic sys power lost Machine will be inoperable</p> </div> <p style="text-align: right;"><small>V1137938</small></p> <p>Contact service Electronic sys power lost Machine will be inoperable</p>	



New X1 work tool
<input checked="" type="radio"/> Push
<input type="radio"/> Toggle
<input type="radio"/> Proportional

V1137912

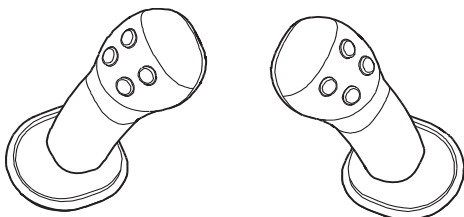

V1065552

Control lever with on/off switch

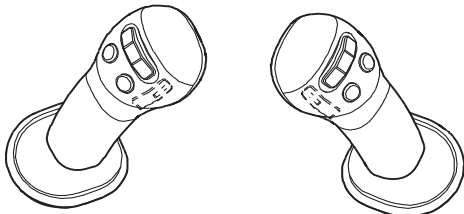

V1065553

Control lever with proportional switch

## Control types for X1 and X3 operation

If a machine has a "proportional control option" for X1 or X3, the user can set one of these 3 types. Otherwise the user is only allowed to set one of 2 types that are "Push" or "Toggle". Refer to page 94 for more details on optional levers.

- Push
- Toggle
- Proportional

### Control using on/off switch on the control lever

- 1 Toggle type in the IC (Instrument Cluster)  
Actuator for X1 or X3 is activated by pressing the on/off switch on the control lever and it will stay active even when the switch is released. The actuator will be deactivated when the same switch is pressed again or the other switch for opposite direction is pressed.
- 2 Push type in the IC (Instrument Cluster)  
Actuator for X1 or X3 is activated while the on/off switch is pressed (On position). The function will be deactivated when the on/off switch is released.

### Control using proportional switch on the control lever

- 1 Toggle and Push-button type in the IC (Instrument Cluster)  
These controls with proportional switch are similar as the ones with on/off switch but it has a special point to activate the actuator because the proportional switch also has a proportional value.  
In toggle type, the actuator will be activated by moving the proportional switch to one direction and it will be deactivated when the switch is moved to same direction again or to opposite direction.
- 2 Proportional type in the IC (Instrument Cluster)  
Actuator for X1 or X3 is activated proportional to the movement of the proportional switch.

## Instrument panel, right

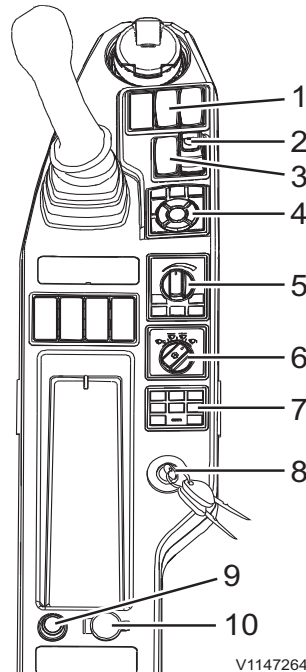

V1147264

- 1 Air compressor switch (optional equipment)
- 2 Attachment quick coupler switch, right (optional equipment)
- 3 Travel speed switch
- 4 IC (Instrument Cluster) control keypad
- 5 Machine control keypad
- 6 Wiper and washer control switch
- 7 Audio remote control switch with Bluetooth
- 8 Ignition switch
- 9 Cigarette lighter (optional equipment)
- 10 Power socket

### 1 Air compressor switch (optional equipment)

This switch is used to operate the air compressor inside the cab.

- Position 0: Air compressor is OFF
- Position 1: Air compressor is ON

#### NOTE!

The switch is returned automatically.

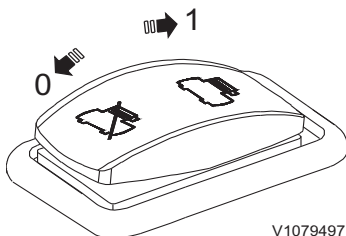

V1079497

## 80 Instrument panels Instrument panel, right

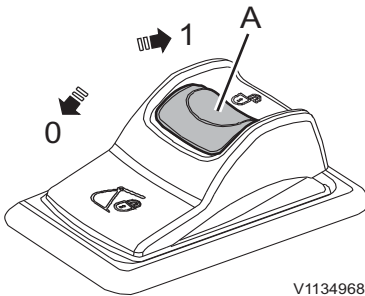

A Lock device

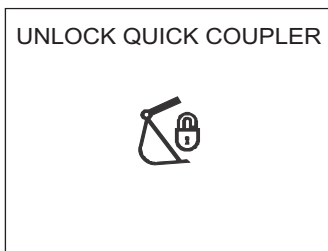

V1147253

Unlock quick coupler

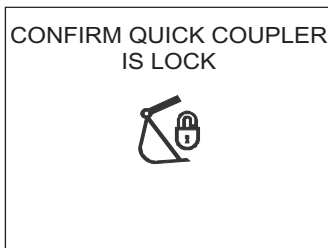

V1147255

Confirm quick coupler is locked

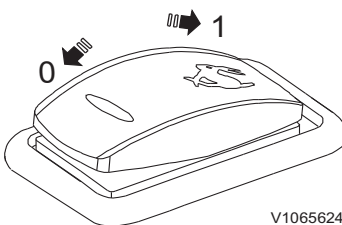

V1065624

### 2 Attachment quick coupler switch, right (optional equipment)

- Position 0: Attachment quick coupler, lock control
- Position 1: Attachment quick coupler, initiating control

Press down to release the red lock device (A) and then press the switch to position (1) to initiate the attachment quick coupler.

When the attachment quick coupler is initiated, the buzzer sounds and the check message and indicator are displayed on the IC (Instrument Cluster).

#### NOTE!

The attachment quick coupler switch for activation on the left instrument panel must be pressed to open the attachment quick coupler. See page 35 for operation.

After installing the attachment quick coupler, press the switch to position (0) to close the attachment quick coupler. When the switch is in position (0), the buzzer sounds and the check message for confirming and indicator are displayed on the IC (Instrument Cluster).

#### NOTE!

Press the attachment quick coupler switch on the left instrument panel to confirm that the attachment quick coupler is locked. See page 35 for the operation.

### 3 Travel speed switch

- Position 0: Travel at LOW speed only
- Position 1: Travel at LOW or HIGH by automatic shift according to travel condition

#### NOTE!

Stop the machine before selecting a different travel speed. Low speed should be selected for grades, on soft ground, in restricted spaces, and when the machine is loaded onto or unloaded from a transport vehicle.

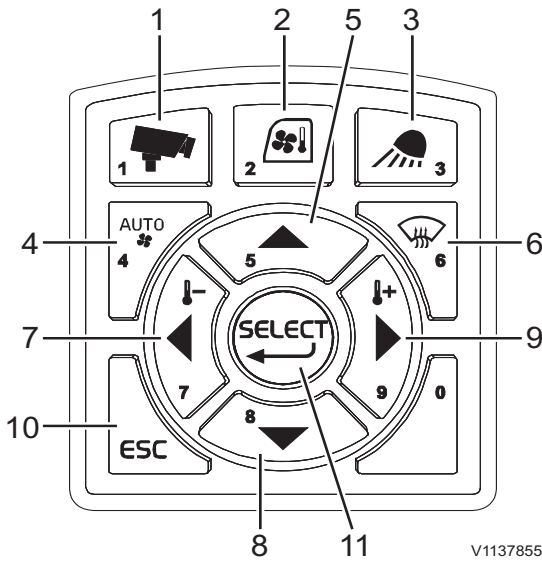

- 1 Camera button
- 2 HVAC control button
- 3 Work lights control button
- 4 HVAC auto-mode select button
- 5 Arrow up button
- 6 Defroster select button
- 7 Arrow left button
- 8 Arrow down button
- 9 Arrow right button
- 10 ESC button
- 11 SELECT button

#### 4 IC (Instrument Cluster) control keypad

##### 1) Camera button (if installed)

This button is used to control the camera screen in the IC (Instrument Cluster).

- A short press on the camera button shows the camera view with the gauges at the top of the screen.
- A long press on the camera button shows the camera configuration bar. For detailed information about camera control, see page 131 and 133.

##### 2) HVAC control button

This button is used to control the HVAC system. See page 115.

##### 3) Work lights control button

This button is used to control the work lights on the boom, cab, deck, and counterweight.

- Press the button short to turn on or off the work lights. All settings remain if the system is turned off.
- Press and hold in the button to set the work lights. Use the arrow buttons to select the required work light, and then press the SELECT button on the IC control keypad to turn on or off the work light. When selecting "All", all work lights are turned on or off.

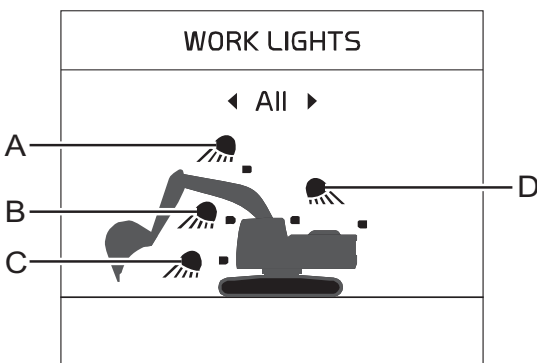

- A Boom work light
- B Cab front light
- C Deck work light
- D Cab rear and counterweight lights

**4) HVAC auto-mode select button**

This button is used to control the HVAC system. See page 115.

**5) Arrow up button**

This button is used to scroll between items and adjust each segment on the screen.

**6) Defroster select button**

This button is used to activate the defroster. See page 115.

**7) Arrow left button**

This button is used to move the cursor to the left. Also press the button in order to decrease values.

**8) Arrow down button**

This button is used to scroll between items and adjust each segment on the screen.

**9) Arrow right button**

This button is used to move the cursor to the right. Also press the button in order to increase values.

**10) ESC button**

This button is used to go back to the previous screen or to cancel without saving. The ESC button is also used to turn off the warning light and sound.

**11) Select button**

This button is used to confirm the item or setup that the user selects.

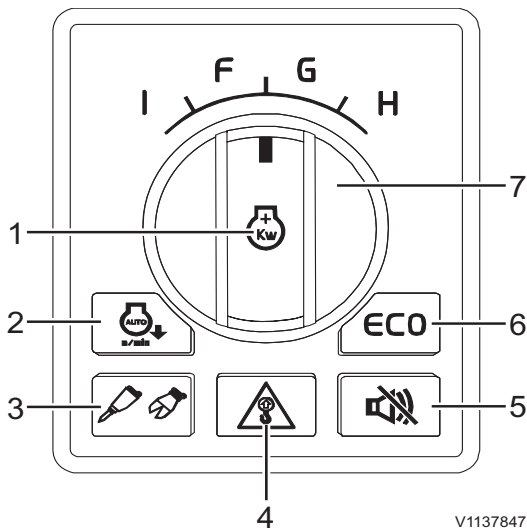

V1137847

- 1 Power max. mode switch
- 2 Auto idle button
- 3 Hammer/Shear button
- 4 Overload warning button
- 5 Travel alarm stop button
- 6 ECO button
- 7 Engine speed/Work mode control switch

## 5 Machine control keypad

### 1) Power max. mode switch

Press down this switch to activate power maximum mode.

**At step 9 of the engine speed control switch,**

Normal condition = H-mode

Press down the switch = P-mode

If the machine is not operated in P-mode for more than 5 seconds and the auto idle selector switch is activated, the engine speed automatically goes down to idle mode. When the machine is operated again, it returns to P-mode again. In P-mode, it becomes H-mode if step 9 is selected after turning the engine speed control switch to another step.

### 2) Auto idle button

Auto idle button activates or deactivates "Auto idle" function of the GPMECU1 (General Purpose Machine Electronic Control Unit1).

The engine speed will be reduced automatically to idle in order to reduce fuel consumption if any of control levers, travel levers (pedals) or engine speed control switch are not operated for 5 seconds. If any one of the above is operated, the engine speed returns to the speed set with the engine speed control switch.

### 3) Hammer/Shear button

This button is used to activate the hammer/shear function.

Before operating the functions below, the hammer/shear button should be activated.

### NOTE!

This instruction can be changed according to the types of operating lever. For more information about operating levers, see page 94.

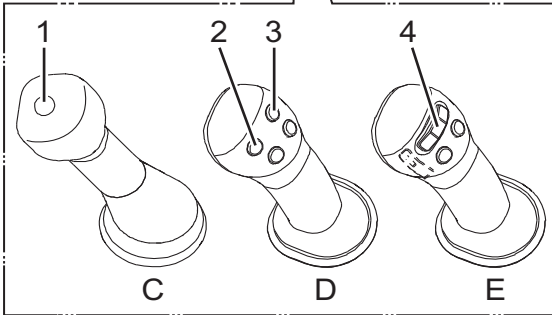
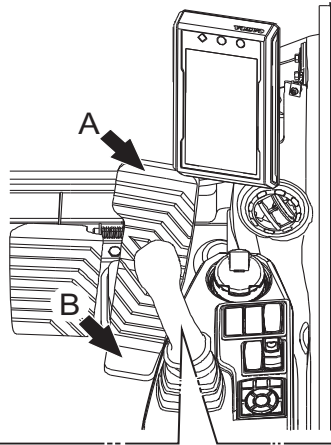

V1137128

**NOTE!**

Select the X1 work tool on the IC (Instrument Cluster), see page 43 for details.

**If a pedal is provided with X1 option (hammer/shear)**

The pedal should be adjusted if it is used for hammer or shear. Refer to page 94 for details.

■ Hammer mode

Hammer will work when the pedal is pressed forward (A).

■ Shear mode

Shear will work when the pedal is pressed forward (A) or backward (B).

**If control lever with one button (C) is installed**

■ Hammer mode

Hammer will work when button (1) is pressed.

**NOTE!**

When the hammer/shear function is not activated if this button is pressed, the power boost will be activated.

**If control lever with four buttons (D) is installed**

■ Hammer mode

Hammer will work when button (2) is pressed.

**NOTE!**

There will be no response when button (3) is pressed.

■ Shear mode

Shear will work when button (2) or (3) is pressed.

**If control lever with proportional switch (E) is installed**

■ Hammer mode

Hammer will work when proportional switch (4) is moved to left side.

**NOTE!**

There will be no response when the proportional switch is moved to right side.

■ Shear mode

Shear will work when proportional switch (4) is moved to left or right side.



#### 4) Overload warning button

Overload warning button activates or deactivates "Overload warning" function. This button is to display a symbol and to generate an alarm if the "overload signal" is detected.

- First event of overloading: The pop-up message will be displayed and a warning alarm sounds. The warning indicator is also shown on indicator screen. The pop-up message will disappear only when the ESC button is pressed.
- When the event occurs again when operating the machine: A warning alarm sounds and the indicator is shown. When reducing the load, the alarm and indicator will turn off.

#### 5) Travel alarm stop button

Travel alarm stop button is used to activate or deactivate "Travel alarm" function of the GPMECU1 (General Purpose Machine Electronic Control Unit1). "Travel alarm" function is activated whenever the ignition switch is on.

#### NOTE!

When starting the machine travel, the travel alarm always sounds for 5 seconds even though the travel alarm stop function is activated.

#### 6) ECO button

ECO function is a mode for fuel economy when working with the machine.

When pressing the ECO button on the keypad, then pump control works for fuel economy. The button will light up and also an ECO symbol is shown on the IC (Instrument Cluster) when activated. Press the button again to disable the function and the button light and symbol on the IC will turn off.

#### NOTE!

When the ignition switch is on, ECO mode is always activated automatically. (except North America region)

#### NOTE!

This mode is only available for P-, H-, G1-, G2-, G3-, and G4-mode of the engine speed/work mode control switch.

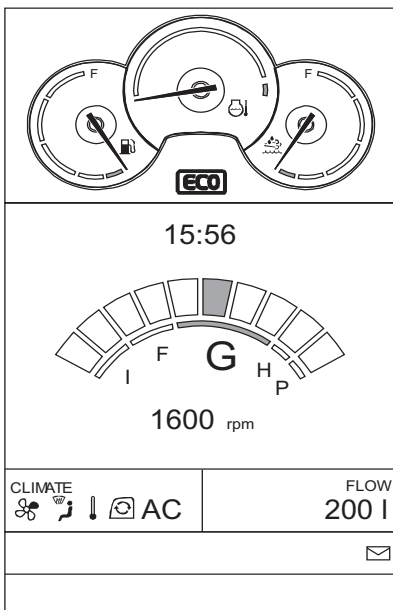

V1137848





86 Instrument panels  
Instrument panel, right

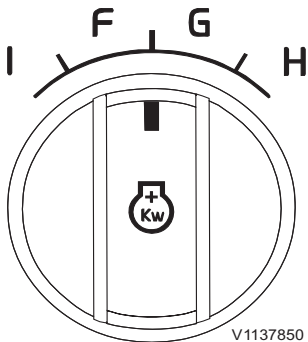

7) Engine speed/Work mode control switch

Nine (ten in cases where P-mode is used) different throttle positions are available through the control of this switch. Turning this switch, the engine speed will change incrementally. According to the selected engine speed, work mode will be set automatically and setting mode is displayed on the main screen in the front instrument panel.

Except North America

Mode		Switch step	Engine speed ( $\pm 40$ rpm) (no load/load)	Remarks
Power max.	P	9	1900 / 1800 over	For maximum productivity during hard digging and trenching
Heavy	H		1800 / 1700 over	For moderately hard operations
General	G1	8	1700 / 1600 over	For economical operation during general applications
	G2	7	1600 / 1500 over	
	G3	6	1500 / 1400 over	
	G4	5	1400 / 1300 over	
Fine	F1	4	1300 / -	For Maximum lifting power and moderate control
	F2	3	1200 / -	
Idle	I1	2	1000 / -	For low idle, warm-up, and high-precision operation
	I2	1	800 / -	

North America

Mode		Switch step	Engine speed ( $\pm 40$ rpm) (no load/load)	Remarks
Heavy	H	9	1900 / 1800 over	For maximum productivity during hard digging and trenching
General	G1	8	1800 / 1700 over	For economical operation during general applications
	G2	7	1700 / 1600 over	
	G3	6	1600 / 1500 over	
	G4	5	1400 / 1300 over	
Fine	F1	4	1300 / -	For Maximum lifting power and moderate control
	F2	3	1200 / -	
Idle	I1	2	1000 / -	For low idle, warm-up, and high-precision operation
	I2	1	800 / -	

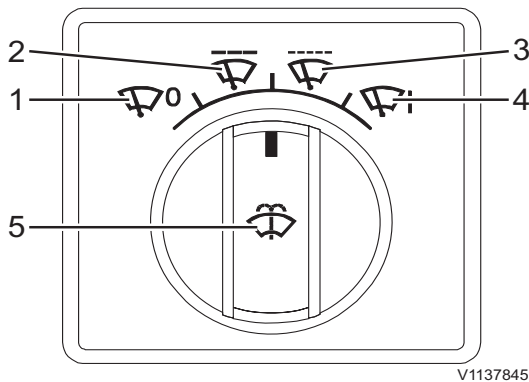

## 6 Wiper and washer control switch

Turn the wiper and washer control switch to the desired position.

### 1) Wiper off

2) Wiper interval 1: After one operation, off for 5 seconds

3) Wiper interval 2: After one operation, off for 2 seconds

### 4) Wiper continuous

5) Washer: Press down this switch to work the washer

## **NOTICE**

Do not keep the washer switch pressed in for more than 20 seconds. Do not use the washer, if the reservoir for washer fluid is empty.

## **NOTE!**

When using the joystick shortkey;

- Press the joystick shortkey button briefly on the left control lever for the wiper operation.
- Keep pressing the button for the wiper and washer operation.

88 Instrument panels  
Instrument panel, right

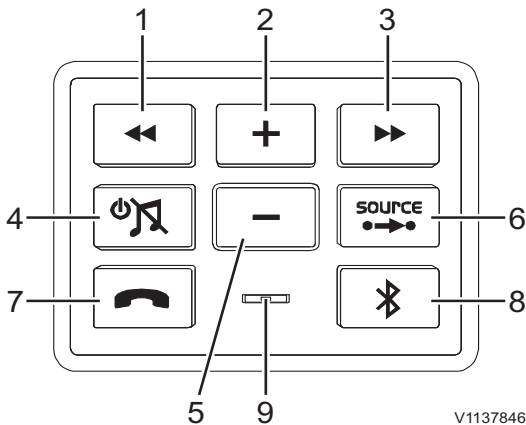

- 1 Auto-select channel button (downward)  
Music select button (backward)
- 2 Volume up button
- 3 Auto-select channel button (upward)  
Music select button (forward)
- 4 Power on/off, Mute toggle button
- 5 Volume down button
- 6 Source change button
- 7 Call button
- 8 Bluetooth button
- 9 Call mic

**7 Audio remote control switch with Bluetooth**

**1) Auto-select channel button (downward)**

Press the button to search channels automatically. It searches the lower frequencies automatically and stops at a receivable frequency.

**Music select button (backward)**

It selects the previous song in the play list in your cell phone.

When music plays for more than 1 second, it turns back to the start of the song, and if you press the button again, it returns to the previous song.

**2) Volume up button**

Press the button to increase the volume. Keep pressing it to increase volume gradually.

**3) Auto-select channel button (upward)**

Press the button to search channels automatically. It searches the higher frequencies automatically and stops at a receivable frequency.

**Music select button (forward)**

It selects the next song in the play list in your cell phone.

**4) Power on/off, Mute toggle button**

Press the button to turn On/Off the audio power and to change between Mute/Output.

- Press shortly → Mute/Press shortly → Unmute
- Keep pressing the button → Power off

**5) Volume down button**

Press the button to reduce volume. Keep pressing it to reduce the volume gradually.



#### 6) Source change button

By pressing the FM/AM button, the radio starts and radio modes change (RADIO/USB/AUX).

By pressing this button, you can change the source of music played by the audio system. When you press this button in Bluetooth mode, it changes into Connected Audio Control Mode.

#### 7) Call button

Press Bluetooth (connected audio control mode) button for actions related to calls, including calling/hanging up/answering/rejecting.

When the phone rings, this button flashes green, and during a conversation, the light is on with fixed green.

- Not calling: Calling
- In calling: Hanging-up
- Flashing (phone ringing): Answering
- Keep pressing the button while flashing: Rejecting
- Call function of the button above calls the previous number

#### 8) Bluetooth button

By pressing this button, the following functions will work according to the machine's Bluetooth connection status.

- Not connected: Requesting connection to the previously connected device
- Connected: Change to Bluetooth mode
- Keep pressing the button when connected: Disconnect Bluetooth

#### 9) Call mic

When you talk using a hands-free device, you can transmit a voice with this mic.

90 Instrument panels  
Instrument panel, right

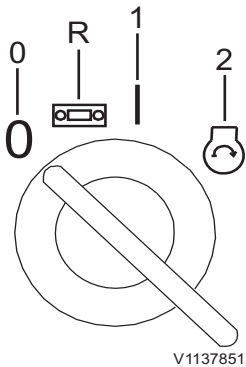

- OFF position (0)
- Radio position (R)
- Operating (preheating) position (1)
- Start position (2)

## 8 Ignition switch

This ignition switch has four positions. Make sure to activate the battery disconnect switch before trying to start engine.

### OFF position (0)

Turn the ignition switch to position (0) to turn off engine.

### Radio position (R)

Turn the ignition switch to position (R) to turn on the radio.

### Operating (preheating) position (1)

The machine is equipped with an automatic engine preheating system. When the ignition switch is turned to position (1), the vehicle's electronic system will be active, thus activating the automatic engine preheating system.

### Start position (2)

When the ignition switch is turned to position (2) the starter motor will be engaged to crank the engine, provided that the battery disconnect switch has been activated. The starter motor will not crank as long as the control lockout lever is in unlocked (up) position. Refer to page 109 for details on the control lockout lever.

## Instrument panels Instrument panel, right 91

### 9 Cigarette lighter (optional equipment)

Press it down, and in a few seconds it will return to original position. At this time it is ready to use (24 V).

#### **NOTICE**

The voltage in the cigarette lighter socket is 24 V. Therefore, do not connect any 12 V appliances.

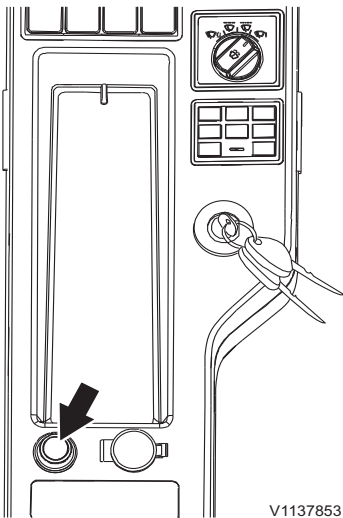

### 10 Power socket

This socket is for electrical appliances such as a mobile phone charger. Capacity: under 12 V (10 A)

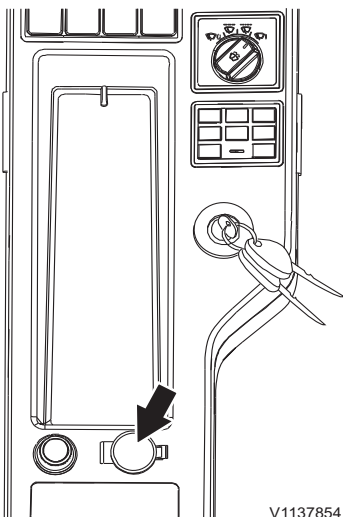

## Instrument panel, rear

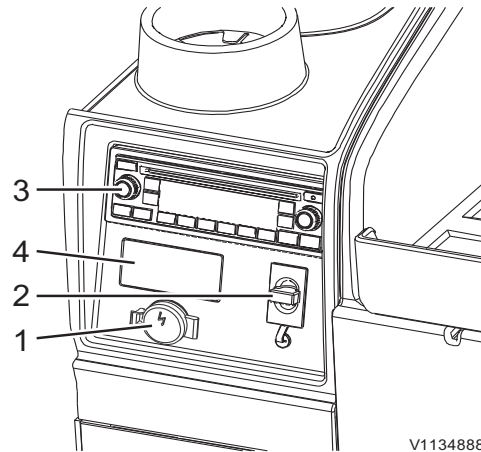

V1134888

- 1 Power socket
- 2 Service socket
- 3 Audio system (optional equipment)
- 4 Auxiliary heater (optional equipment)

### 1 Power socket

This socket is for electrical appliances such as a mobile phone charger or refrigerator.  
Capacity: 24V (10A)

### 2 Service socket

This socket is for Volvo's service tools (MATRIS and Tech Tool).

### 3 Audio system (optional equipment)

See page 125.

### 4 Auxiliary heater (optional equipment)

See page 136.

## Other controls

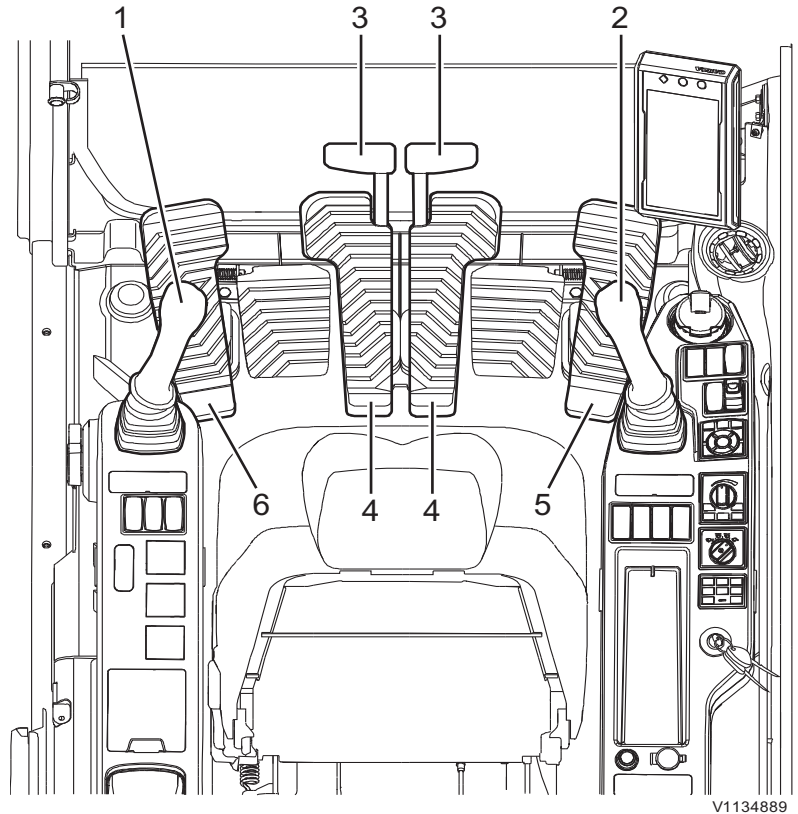

V1134889

1	Left control lever
2	Right control lever
3	Travel levers
4	Travel pedals
5	Optional pedal (X1)
6	Optional pedal (Straight travel) Optional pedal (Variable adjustable boom)

The control levers of this machine is set from factory to operate in ISO/SAE standard operating pattern for optimum machine performance.

Some machines may have the optional pattern change valve. Refer to page 94 for more details.

On machines equipped with the optional pattern change valve, the indicator of chosen pattern will be shown on the IC (Instrument Cluster).



## Controls

### 1 Left control lever

This lever is for swing superstructure and moving dipper arm.

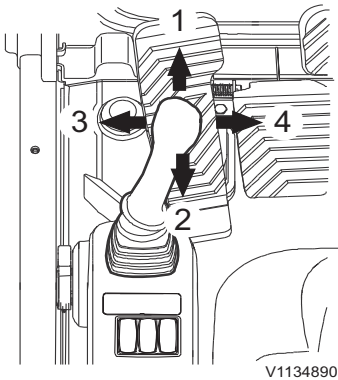

- 1 Dipper arm out
- 2 Dipper arm in
- 3 Left swing
- 4 Right swing

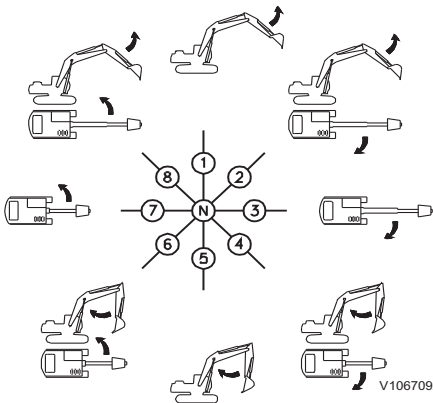

- N Neutral (superstructure and dipper arm in neutral position)
- 1 Dipper arm out
- 2 Dipper arm out and swing superstructure right
- 3 Swing superstructure right
- 4 Dipper arm in and swing superstructure right
- 5 Dipper arm in
- 6 Dipper arm in and swing superstructure left
- 7 Swing superstructure left
- 8 Dipper arm out and swing superstructure left

## 2 Right control lever

This lever is for moving boom and bucket.

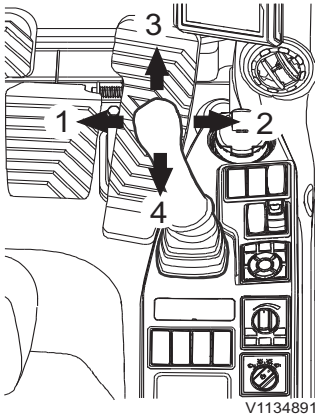

- 1 Bucket in
- 2 Bucket out
- 3 Boom lower
- 4 Boom raise

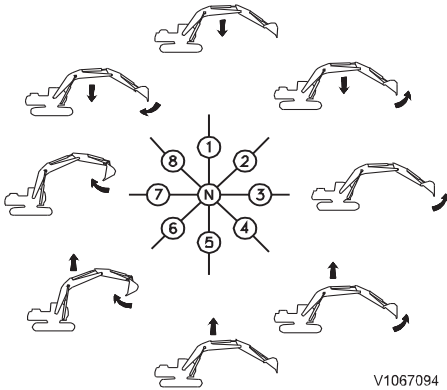

- N Neutral (boom and bucket are maintained at rest position)
- 1 Lower boom
- 2 Lower boom and bucket out
- 3 Bucket out
- 4 Raise boom and bucket out
- 5 Raise boom
- 6 Raise boom and bucket in
- 7 Bucket in
- 8 Lower boom and bucket in

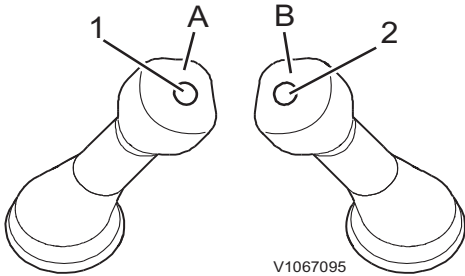

**Control lever with one button**

- A Left operating lever
- B Right operating lever
- 1 Horn button
- 2 Boost/hammer button

**NOTE!**

When the hammer select switch is activated, the boost function does not work.

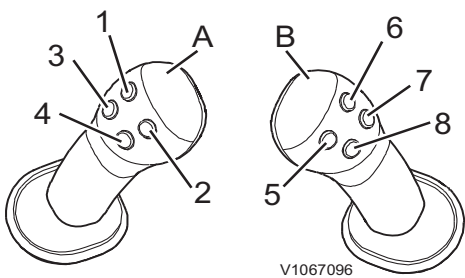

**Control lever with four buttons**

- A Left operating lever
- B Right operating lever
- 1 Rotator button
- 2 Rotator button
- 3 Horn button
- 4 Joystick shortkey button
- 5 Hammer/shear button
- 6 Shear/unassigned
- 7 Float button
- 8 Boost button

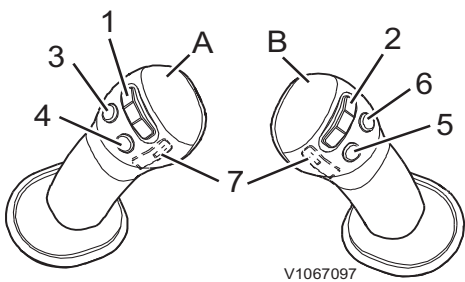

**Control lever with three buttons and proportional switch**

- A Left operating lever
- B Right operating lever
- 1 Proportional switch (rotator)
- 2 Proportional switch (hammer/shear)
- 3 Horn button
- 4 Joystick shortkey button
- 5 Boost button
- 6 Float button
- 7 Unassigned

**NOTE!**

Before operating the control levers for X1 or X3 operation, make sure to read and understand the different control types for the different buttons and switches, refer to page 78 for details.

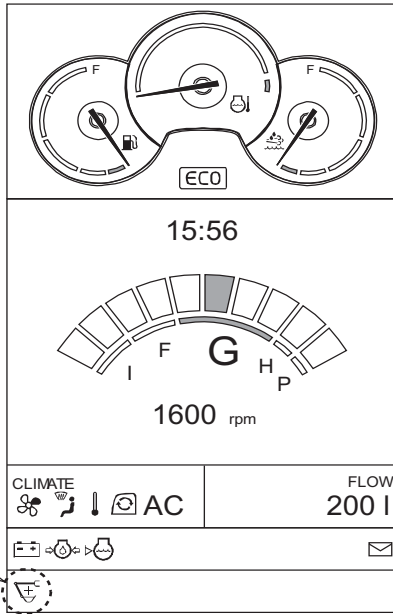

V1134892

Indicator for power boost

### Power boost function

The power boost is designed to increase dipper arm / bucket forces, and lifting capacities. When digging in P, H or G modes in extremely hard digging conditions, it is recommended to press the power boost button before starting the digging cycle.

Digging force will be increased for 9 seconds, which is sufficient time for the operator to load the bucket. After the 9-second period, the power boost is turned off automatically.

The power boost indicator is shown on the indicator screen of IC (Instrument Cluster) whenever it is activated. In F-mode, the power boost is activated continuously for maximum lifting capacity.

98 Other controls  
Controls

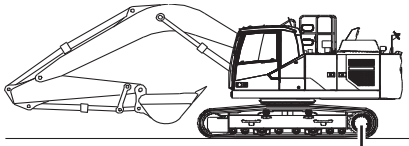

A V1147331

A Sprocket

3 Travel levers

4 Travel pedals

These are used to move and stop the machine.

**NOTICE**

In this Operator's Manual front, forward, rear, rearward, right and left are based on the premiss that the sprockets are placed behind the cab. Pay attention to this before control levers and pedals are used.

If you want to travel the machine continuously, keep in mind below operating conditions.

Ground conditions	Operation
Flat, normal or soft soil	Do not travel continuously for more than 2 hours. If you want to travel for more than 2 hours at high speed, stop for more than 20 minutes. Otherwise, track rollers and idlers could be overheated and lead to oil leakage. <b>NOTE!</b> Travel the machine to forward direction (to idler side) to reduce wear to moving parts of the undercarriage.
Uneven or tough soil (mixed of gravels, stones, boulders, other obstacles or on a slope)	Travel the machine at low speed and do not travel continuously for more than 1 hour. If you want to travel for more than 1 hour, stop for more than 20 minutes. Otherwise, track rollers and idlers could be overheated and lead to oil leakage. <b>NOTE!</b> Travel the machine to forward direction (to idler side) to reduce wear to moving parts of the undercarriage.

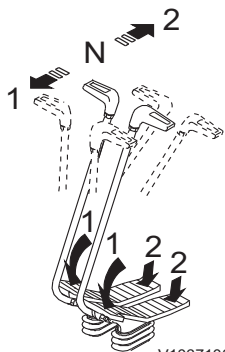

V1067100

N Neutral (machine stops)

1 Forward Push the lever forward or press down front end of the pedal to advance the machine, when the sprocket is at the rear of the machine.

2 Reverse Pull the lever rearward or press down rear end of the pedal to reverse the machine, when the sprocket is at the rear of the machine.

**NOTE!**

When the sprockets are at the front side of the machine, the machine will be moved to the opposite direction as to above.

- The distance the travel levers/pedals are pulled or pushed determines the travel speed of the machine. That is, if the levers/pedals are pushed or pulled fully, the machine will travel at the maximum speed, provided that the high travel speed has been selected and the engine RPM is at full throttle position.
- The machine brakes are engaged automatically when the travel controls are moved to the neutral position. To reduce the travel speed, slowly return the travel controls to the center (neutral) position.
- In cold weather, the travel function may be heavier than normal due to the oil viscosity.

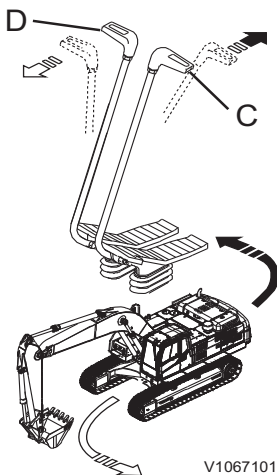

**Left turn**

- 1 When the sprockets are at the rear side of the machine Push the right lever (D) forward, the RH track rotates forward and the machine travels forward as it turns to the left.  
Pull the left lever (C) backward, the LH track rotates in reverse and the machine travels backward as it turns to the left.
- 2 When the sprocket is at the front side of the machine Operate levers (C or D) in the opposite direction as to above.

100 Other controls  
Controls

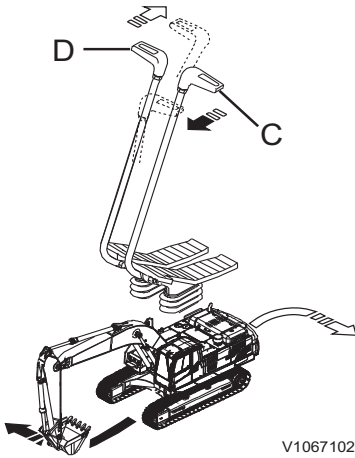

**Right turn**

- 1 When the sprockets are at the rear side of the machine  
Push the left lever (C) forward, the L/H track rotates forward and the machine travels forward as it turns to the right.  
Pull the right lever (D) backward, the R/H track rotates in reverse and the machine travels backward as it turns to the right.
- 2 When the sprocket is at the front side of the machine Operate levers (C or D) in the opposite direction as to above.

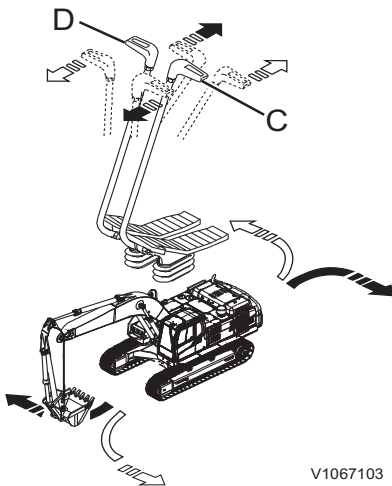

**Spin turn**

- 1 When the sprockets are at the rear side of the machine  
Pull the left lever (C) backward, the L/H track rotates in reverse; simultaneously push right lever (D) forward, the R/H track rotates forward and the machine turns on the spot quickly to the left.  
Pull the right lever (D) backward, the R/H track rotates in reverse; simultaneously push left lever (C) forward, the L/H track rotates forward and the machine turns on the spot quickly to the right.
- 2 When the sprocket is at the front side of the machine  
Operate levers (C or D) in the opposite direction as to above.

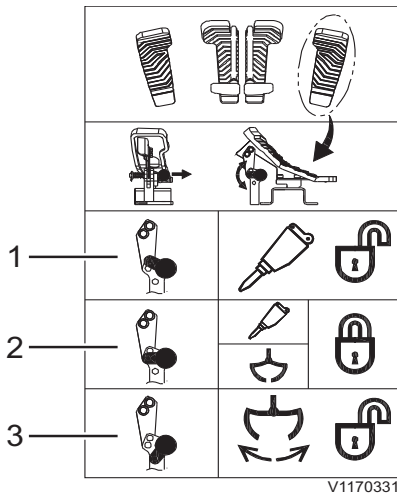

### 5 Optional pedal (X1)

Position 1: Operating hammer

Position 2: Lock the pedal

Position 3: Operating shear or crusher

#### NOTICE

Make sure that the pedal is in locked position when it is not used in order to prevent unwanted manoeuvres.

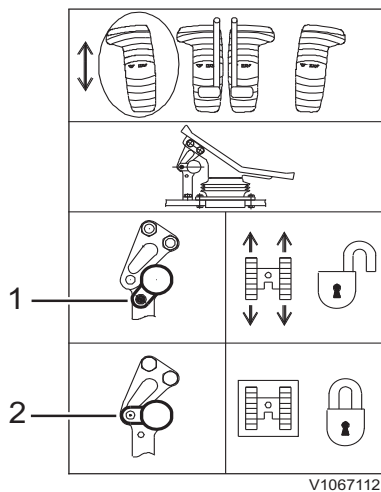

### 6 Optional pedal (straight travel)

Position 1: Operating straight travel

Position 2: Lock the pedal

#### NOTICE

Make sure that the pedal is in locked position when it is not used in order to prevent unwanted manoeuvres.

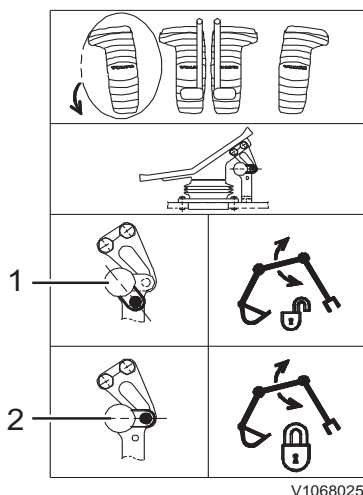

### Optional pedal (Variable adjustable boom)

Position 1: Operating variable adjustable boom

Position 2: Lock the pedal

#### NOTICE

Make sure that the pedal is in locked position when it is not used in order to prevent unwanted manoeuvres.



### Optional parts

#### Bucket/grapple valve position

Select the correct position by turning the nut with a wrench.

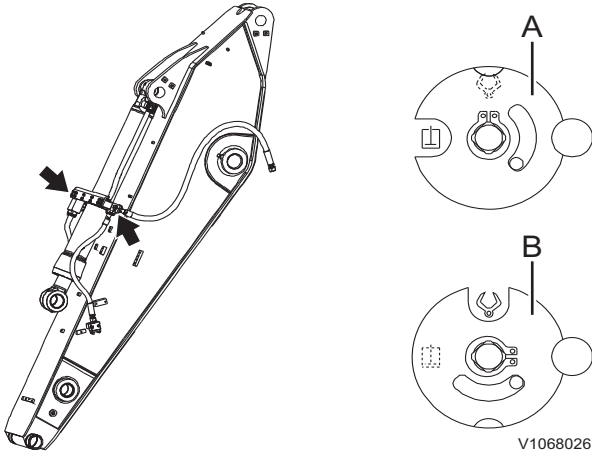

- A Bucket position
- B Grapple position

#### Changing control pattern of the machine (optional equipment)

- Position S: ISO/SAE type
- Position B: Backhoe loader type

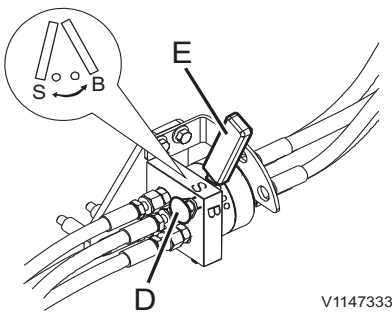
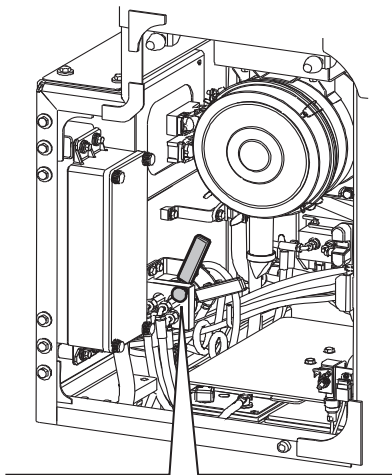

### **!** WARNING

Risk of serious accidents.  
Unfamiliar control patterns could cause confusion and accidents resulting in serious injury.  
**Use extreme caution when using the control levers after changing the control pattern and until you become familiar with the new pattern.**

### NOTICE

Selected control pattern is shown on the front instrument panel. It is important to check this before using the machine.

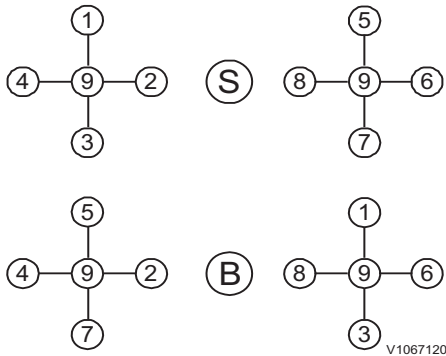









The machine control pattern can easily be changed to the ISO/SAE system or to the backhoe loader hydraulic system by changing the position of pattern change valve (if fitted).

Use the following procedure to change the position of the pattern change valve (The standard position of machine is ISO/SAE pattern type (S).

- 1 Pull the knob (D) down and move the lever (E) to S (ISO/SAE type) position or to the B (Backhoe loader type) position by turning.
- 2 After you set the machine control pattern, release the knob.

The patterns on the left side of the illustration show the possible configurations for the left control lever. The patterns on the right side of the illustration show the possible configurations for the right control lever.

 <p>V1067121 Dipper arm out (1): Move the control lever to this position in order to move the dipper arm outwards.</p>	 <p>V1067122 Swing right (2): Move the control lever to this position in order to swing the superstructure to the right.</p>	 <p>V1067123 Dipper arm in (3): Move the control lever to this position in order to move the dipper arm inwards.</p>
 <p>V1067124 Swing left (4): Move the control lever to this position in order to swing the superstructure to the left.</p>	 <p>V1067125 Boom lower (5): Move the control lever to this position in order to lower the boom.</p>	 <p>V1067126 Bucket dump (6): Move the control lever to this position in order to dump the bucket.</p>
 <p>V1067127 Boom raise (7): Move the control lever to this position in order to raise the boom.</p>	 <p>V1067128 Bucket close (8): Move the control lever to this position in order to close the bucket.</p>	<p>HOLD (9): When the control lever is released from any position, the control lever will return to the HOLD position. Movement of the superstructure will stop.</p>

104 Other controls  
Controls

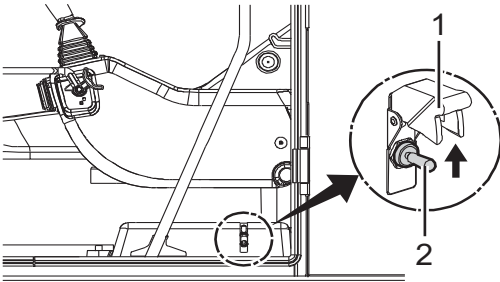

V1137921

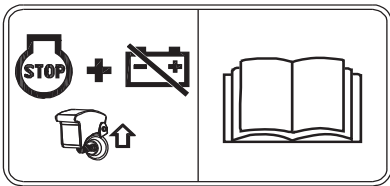

V1137926

### Emergency stop switch

**NOTE!**

Emergency stop switch must be used only in case of emergency situation.

If it is abused or misused by the operator, it could cause serious failure of the engine and machine. Never use the emergency stop switch for the purpose of shutting off the normal machine.

Turn the ignition switch to the OFF position. If the engine does not stop or in emergency, perform the following procedure.

- Open cover (1) and push switch (2) upward to stop the engine.

**NOTE!**

This switch turns off the engine as well as the battery disconnect switch at the same time.

- Return the switch to the original position. The engine will be enabled to start.

**NOTE!**

Do not operate the machine again until the malfunction has been corrected.



---

## Cab

### ROPS (Roll Over Protective Structure)

The cab is designed to ensure minimum crash protection space according to ROPS standard for excavator (ISO12117-2).

The installation of any additional equipments resulting in exceeding maximum tested machine weight on a ROPS identification plate, may void ROPS certification.

Do not jump out of cab if the machine should roll over. Keep stay in seat wearing seat belt.

If any part of the cab's protective structure is affected by plastic deformation or failures, the cab shall be replaced immediately.

#### **NOTE!**

Never carry out any unauthorized alterations to the cab, for example lowering the roof height, drilling, welding on brackets for fire extinguisher, radio aerial or other equipment, without first having discussed the alteration with personnel at the Volvo Engineering Department. This department will decide whether the alteration may cause the approval to become void.

It is important that all parties concerned are aware of these regulations.



### Protection from falling or scattering materials (optional equipment)

Install the necessary protection guards according to working conditions where falling or scattering materials are capable of entering the operator's cab.

#### **FOG (Falling Object Guard) and FOPS (Falling Object Protective Structure)**

FOG and FOPS should be adopted when the machine is expected to work in an area where materials are capable of falling to the cab. Especially, in mining applications, FOG shall be adopted.

#### **Safety net**

Install safety net to minimize the possibility of breaking windshield when working with a breaker.

The above recommendations are based on standard working, install the necessary additional protection guards in accordance with job site conditions and local government regulations. Contact authorized Volvo dealer to meet local regulations.

Any damage can affect the strength of the structure. Contact a qualified service technician for repairing safety structure after damage.

Prevent persons from entering or remaining in the dangerous area.

### **NOTICE**

Check the clearance between bucket and cab or spill guard by carefully moving the bucket as close to the cab as possible. The risk of the bucket knocking against the cab is greater if attachment quick coupler is used or if the bucket is provided with lifting eyes.

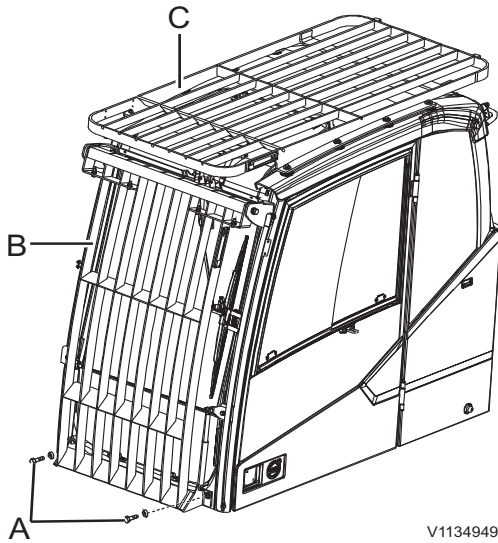

- A Screws
- B+C FOG
- C FOPS

### Windshield with FOG, cleaning

- 1 Remove the screws (A), and then tilt the FOG.
  - 2 Clean the windshield.
  - 3 Fasten the screws (A) with regulated torque by pushing the FOG. ( $48 \pm 4.9 \text{ Nm}$  /  $4.9 \pm 0.5 \text{ kgfm}$  /  $35.5 \pm 3.6 \text{ lbf ft}$ )
- Do not operate the machine while FOG (Falling Object Guard) is tilted. Otherwise, FOG can be damaged by the bucket.

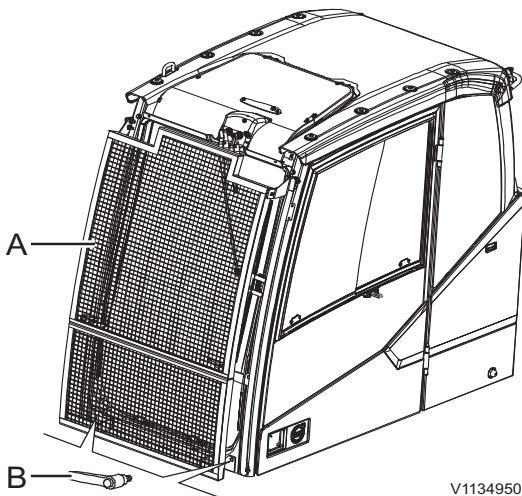

- A Safety net
- B Handle

### Windshield with safety net, cleaning

- 1 Remove the handle (B), and then take away the safety net.
- 2 Clean the windshield.
- 3 Install the safety net.
- 4 Fasten the handle (B) by pushing the safety net.

108 Other controls  
Cab

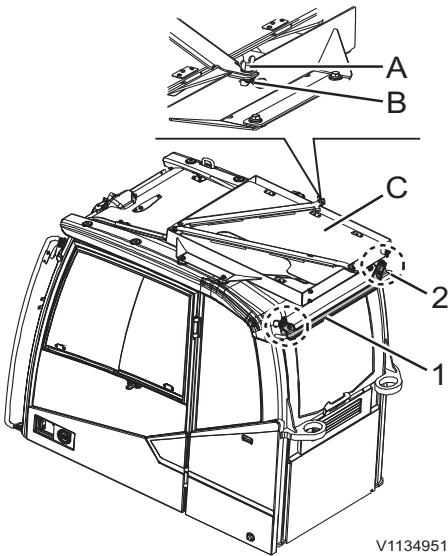

- A Wing nut
- B Pin
- C Covers
- 1 Rear bracket
- 2 Rear handrail

**Anti-vandal kit (optional equipment)**

**NOTE!**

Clean mud, grease, oil, and debris from track surface, steps, walkways, and working platforms before installing the anti-vandalism covers.

Anti-vandal covers are stored on the cab.

The wing nut (A) should be tightened and the pin (B) should also be in right position not to be loosen when operating the machine.

Six brackets are needed to install the covers.

- To install the rear bracket (1), remove the rear handrail (2) and reinstall it with rear bracket.
- Install two front brackets (4). For right side of front bracket, remove the front handrail (3) and reinstall it with front bracket.
- Install two lower brackets (5).
- Install the side bracket (6).

**Tightening torque:**

(1):  $24 \pm 2.4 \text{ Nm} / 2.5 \pm 0.3 \text{ kgf m} / 17.8 \pm 1.8 \text{ lbf ft}$

(2):  $85 \pm 8.8 \text{ Nm} / 8.7 \pm 0.9 \text{ kgf m} / 62.9 \pm 6.5 \text{ lbf ft}$

(3),(4),(5):  $48 \pm 4.9 \text{ Nm} / 4.9 \pm 0.5 \text{ kgf m} / 35.5 \pm 3.6 \text{ lbf ft}$

(6):  $10 \pm 1.0 \text{ Nm} / 1.0 \pm 0.1 \text{ kgf m} / 7.4 \pm 0.7 \text{ lbf ft}$

**NOTE!**

When storing the covers (C), make sure that the locking screws do not cause interference between covers.

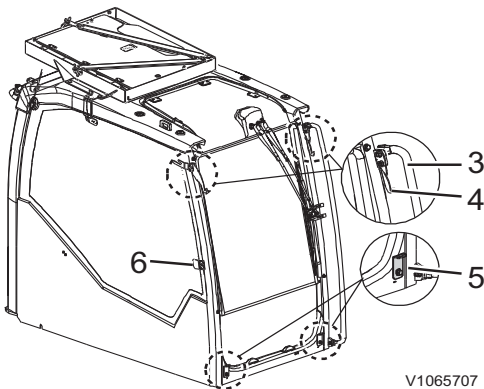

- 3 Front handrail
- 4 Front brackets
- 5 Lower brackets
- 6 Side bracket



## Control lockout system

### WARNING

Risk of serious injury.

Uncontrolled touch of control lever can cause unexpected movement of machine or parts. This could result in serious injury.

**Always lock the control lockout lever before starting the engine or before leaving the operator's seat.**

#### Unlocked position (A)

The control lockout lever is in **"Unlocked"** position (A) for working and travelling operations.

**When the control lockout lever is in this position the engine can not be started.**

#### Locked position (B)

The control lockout lever is used to lock out the attachment, swing and travel unit.

Place this lever on the left control console to **"Locked"** position (B) to lock out the hydraulic control levers and pedals.

**When the control lockout lever is in this position the engine can be started.**

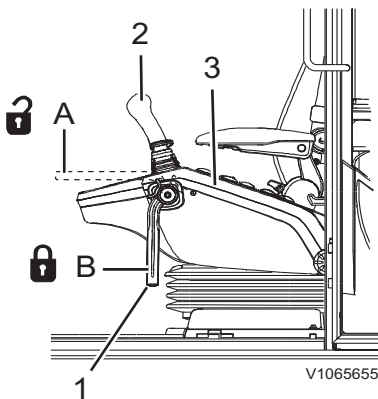

- 1 Control lockout lever
- 2 Left control lever
- 3 Left control console
- A Unlocked position
- B Locked position



## Operator comfort

### Operator seat

The operator seat meets the requirements according to EN ISO7096. The operator seat is designed to provide maximum comfort and reduce vibration to the operator during normal machine operation.

**NOTE!**

Adjusting the seat should always be done when the machine is stationary.

**NOTE!**

Make sure that no objects are placed within the moving area of the operator's seat.

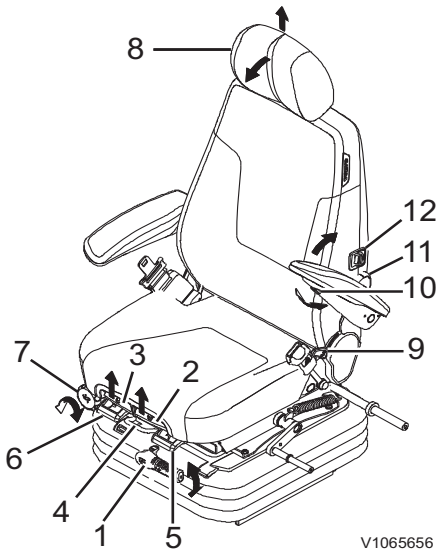

- 1 Weight adjustment
- 2 Fore & aft adjustment, seat cushion
- 3 Angle adjustment, seat cushion
- 4 Horizontal adjustment, top seat
- 5 Horizontal adjustment, top seat and consoles
- 6 X-Isolator adjustment (optional equipment)
- 7 Height adjustment, consoles
- 8 Headrest adjustment
- 9 Backrest angle adjustment
- 10 Armrest adjustment
- 11 Lumbar support adjustment
- 12 Seat heating switch (optional equipment)

**! WARNING**

Risk of serious injury.

Uncontrolled touch of control lever can cause unexpected movement of machine or parts. This could result in serious injury.

**Always lock the control lockout lever before starting the engine or before leaving the operator's seat.**

**NOTICE**

Installation and maintenance of the operator seat may only be carried out by authorised and competent personnel.

**NOTICE**

To obtain maximum comfort and eliminate the risk of accidents, you must make sure that all seat adjustments have been carried out correctly before starting the machine.

**NOTE!**

The seat is intended for use by one seated occupant only.

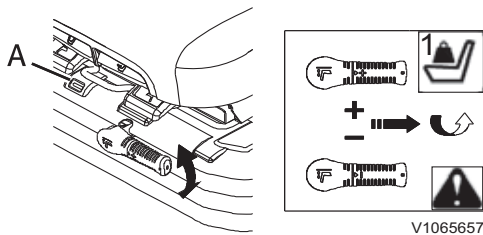

V1065657

A Ride indicator

## Mechanical suspension seat

### 1 Weight adjustment

Adjust the seat to the drivers weight by turning the weight adjusting handle. The set weight should be within the green zone of the ride indicator.

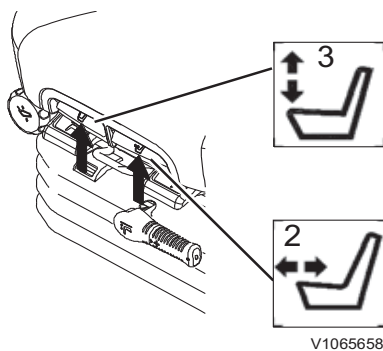

V1065658

### 2 Fore & aft adjustment, seat cushion

Lift the lever (2) and adjust the seat cushion fore & aft.

### 3 Angle adjustment, seat cushion

Lift the lever (3) and adjust the angle of the seat cushion. It may be necessary to reduce occupant pressure on the seat cushion when performing this adjustment.

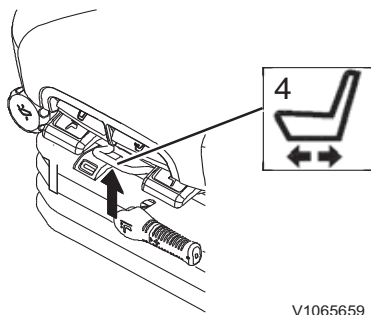

V1065659

### 4 Horizontal adjustment, top seat

It is possible to move the seat forwards and backwards relative to the control consoles. Lift the handle (4) and move the seat so that the consoles are in the desired position relative to the seat. The locking lever must latch in the desired position. It should not be possible to move the seat into another position when it is locked.

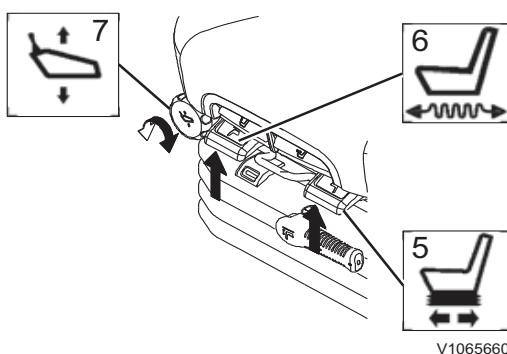

V1065660

### 5 Horizontal adjustment, top seat and consoles

The seat and the consoles can be adjusted forwards and backwards. Lift the lever (5) and move the seat and consoles to the desired position. The locking lever must latch in the desired position. It should not be possible to move the seat into another position when it is locked.

### 6 X-Isolator adjustment (optional equipment)

It is possible to adjust the seat to provide fore and aft isolation. It can be used to reduce fore and aft shocks of the seat. Lift the lever (6) to activate the isolator, push down to deactivate this adjustment.

### 7 Height adjustment, consoles

Rotate the handle (7) and adjust the height of the control consoles.

112 Other controls  
Operator comfort

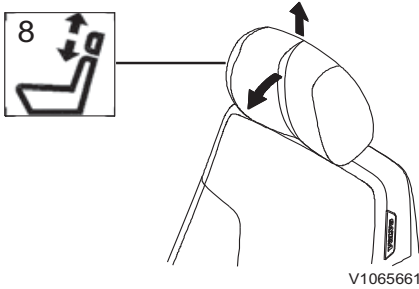

**8 Headrest adjustment**

The headrest can be adjusted for height by pulling up or down. End stops limit the movement. It can be also adjusted for angle by pushing forwards or backwards. End stops limit the movement.

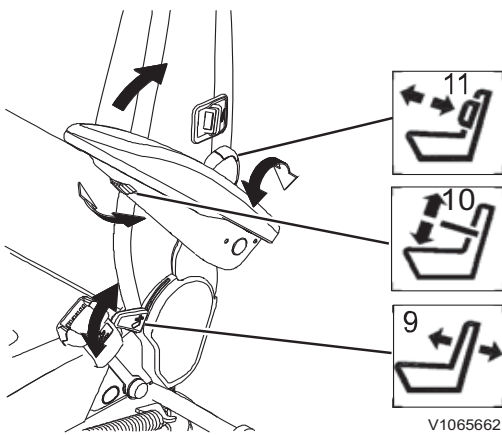

**9 Backrest angle adjustment**

Pulling up the control handle (9) releases the backrest latch. The back of the seat can then be reclined backwards or forwards to the desired position. Releasing the handle allows the backrest to move to a latching position.

The locking lever must latch in the desired position. It should not be possible to move the backrest into another position when it is locked.

**10 Armrest adjustment**

Inclination of the armrest can be changed by turning the adjustment knob (10) mounted on the underside of the armrest. The armrests can be manually tipped up if required.

**11 Lumbar support adjustment**

Rotate the knob (11) in the direction of the arrow to increase the amount of lumbar support (five positions). Further rotation in the same direction causes the lumbar support to return to minimum.

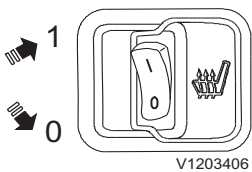

**12 Seat heating switch (optional equipment)**

This is used to warm up the operator seat. The seat heating will activate when this switch is in position (1) and the temperature is under 26 °C (79 °F). The seat heating stops when the temperature is up to 36 °C ( 97 °F), and will activate again when the temperature turns down under 26 °C (79 °F) again.

- 0 Seat heating, OFF
- 1 Seat heating, ON

## NOTICE

To reduce the risk of fire the seat heating must be switched off before you leave the seat.

### Air suspension seat (optional equipment)

The operator seat is also available with air suspension for even better comfort. The adjusting possibilities are the same as for a mechanical suspension seat except adjustment of air suspension.

To adjust air suspension of the seat,

- 1 Turn the ignition switch "ON" or start engine.
- 2 Lift operator's weight off the seat.
- 3 Lift and hold the lever (A) until air bag is completely inflated.
- 4 Sit and push down the lever (A) to deflate.
- 5 Stop deflating when seat starts lowering. The set weight should be within the green zone of the ride indicator.

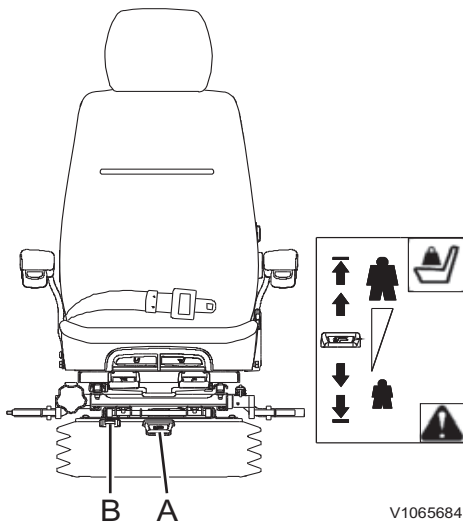

V1065684

- A Adjusting lever  
B Ride indicator

### NOTE!

After adjusting the suspension with operator's weight, the suspension height should be in the position within suspension stroke.

## Seat belt

### WARNING

Risk of serious injury!  
Unexpected machine movement can cause the operator to be ejected from the machine, causing serious injuries.

**Operate the machine only while seated in the operator seat with the seat belt fastened.**

The seat belt is critical to operator safety and must be worn at all times during machine operation to prevent the operator from being ejected from the cab or the operator platform if the machine rolls over or is involved in an accident. A fastened seat belt also helps the operator to maintain control of the machine if it moves suddenly or in an unexpected way. Failure to wear a seat belt during machine operation could result in serious injury or death. The seat belt is intended for one adult only. Keep the belt rolled up when not in use.

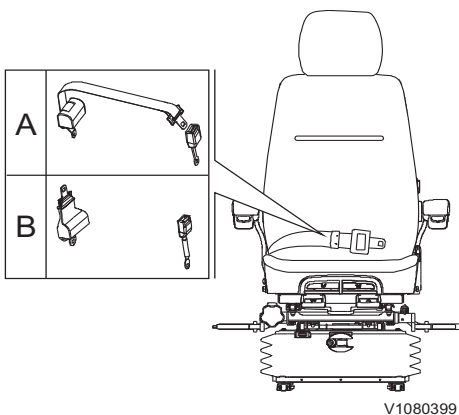

- A Retractable type (2 inches)
- B Retractable type (3 inches)

### WARNING

Risk of serious injury or death.  
A damaged seat belt could cause serious injury or death.

**Check the seat belt and associated parts before start of machine operation.**

Check the seat belt and associated parts daily. Ensure mounting hardware is tight. Replace the entire seat belt immediately if there is any wear, the webbing is worn, cut, has loose stitching, the belt is deformed or the seat belt retractor does not work. Replace the seat belt if the machine has been involved in an accident where the belt has been subjected to high strain or loading. Inspect mounting hardware. Changes to the belt or its mountings must never be made. Only clean with warm water, do not use soap or detergent. Let the belt dry while it is fully pulled out before rolling it in.

Volvo Construction Equipment recommends replacing seat belt assemblies every 3 years regardless of appearance.

## Climate control system

### HVAC system (Heating, Ventilation, Air Conditioning)

The machine can be equipped with different kinds of systems, for example, with air conditioning unit or heater with air conditioning unit. Before operating the system, check the detailed information for your machine.

#### 1) HVAC control button

- Press the button briefly to turn on/off the HVAC system. All settings remain if the system is turned off.
- Press and hold in the button to setup the HVAC system.

#### NOTE!

Even if the HVAC system is turned off, when CCM (Climate Control Module) gets an auxiliary heater signal, the CCM turns on the cooling fan setting 1st step in manual mode.

#### 2) Arrow up button

This button is used to scroll between items and adjust each segment on the screen.

#### 3) Defroster select button

Press the button to activate the defroster. Fresh air mode is selected automatically. In auto mode, if this button is pressed, mode shall change to manual mode.

#### NOTE!

After 20 minutes, this setting is automatically returned to the previous mode.

#### 4) Arrow right button

This button is used to scroll between items and adjust each segment on the screen. Press this button in order to increase the temperature.

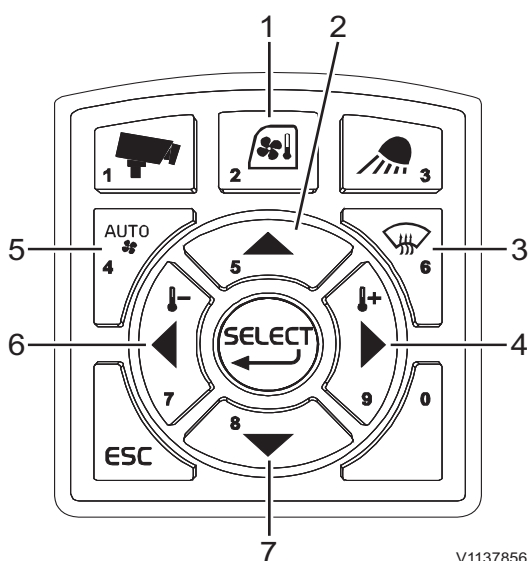

V1137856



### 5) HVAC auto-mode select button

This button is used to select the auto-mode for temperature setting. Required temperature can be changed on the setup menu.

### 6) Arrow left button

This button is used to scroll between items and adjust each segment on the screen. Press this button in order to decrease the temperature.

### 7) Arrow down button

This button is used to scroll between items and adjust each segment on the screen.

## HVAC setup

Press and hold in the HVAC control button (1) to setup the HVAC system.

### A) Climate mode selection

This is for selecting climate mode. (auto, manual, or defrost)

Mode selection and fan speed in manual mode are controlled with the arrow left or arrow right button.

### B) Temperature control

■ **Auto mode:** Temperature can be adjusted with the arrow left or arrow right button.

Default setting value is 22°C (71.6°F) and the setting range is 16°C ~ 32°C (60.8°F ~ 89.6°F). If the temperature sensor in cab fails, auto mode shall turn off.

See page 43 for details on how to change the temperature unit from degrees Centigrade to Fahrenheit.

■ **Manual mode:** Temperature is divided into 8 steps and it can be adjusted with the arrow left or arrow right button. According to the selected step, the temperature will be changed automatically.

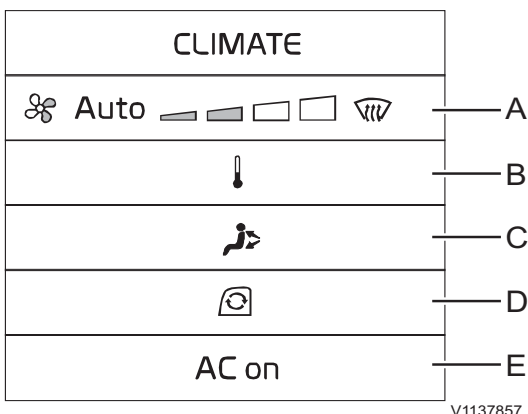

V1137857

**C) Air flow direction**

This is for selecting the direction of the air flow.

**D) Air flow circulation**

This is for selecting the circulation of the air flow.  
(recycle the air inside the cab or draw fresh air from the outside into the cab)

When defrost mode is activated, fresh air mode is selected automatically.

**E) Air conditioner on/off**

This is for turning the air conditioner on/off.



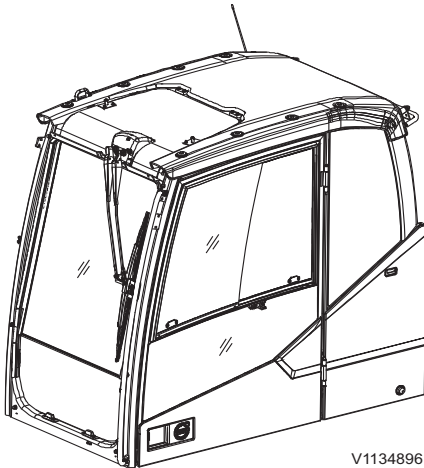

V1134896

## Windows

### Front windshield, opening

#### **NOTICE**

Move the control lockout lever down to its lower position before you open or close the windscreen.

- 1 Lower the attachment to the ground and stop the engine.
- 2 Push both buttons (E) in order to unlatch the windshield from the locked position (G) while holding both grips (F), and then move the windshield upward.

#### **NOTE!**

Stop lifting as soon as the windshield is unlatched.

- 3 Hold both grips (F) only and pull the windshield upward and rearward, and then fix it in the locked position.

#### **NOTE!**

If the windscreen is cracked, it must be replaced immediately. Contact a qualified service technician for replacing.

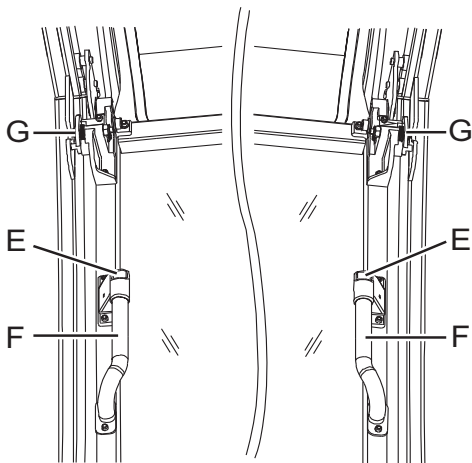

V1065687

### Front windshield, closing

- 1 Lower the attachment to the ground and stop the engine.
- 2 Push the both buttons (E) with holding both grips (F) to move the windshield out of the lock position.
- 3 Grip handle (F) only and pull the windshield downward slowly.
- 4 Fix the windshield securely and tighten in the locked position (G).

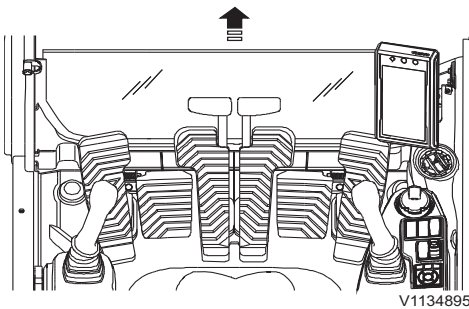

### Lower window, removing

- 1 Open the front windshield.
- 2 Grip the upper part of lower windshield with both hands and pull it upward.
- 3 Put the removed windshield in the storing position inside the cab door.
- 4 Turn the locking handle to lock position (B).

#### NOTE!

Ensure that the lower windshield is locked correctly in the storing position.

#### NOTE!

Be careful not to drop the windshield when releasing the locking handle.

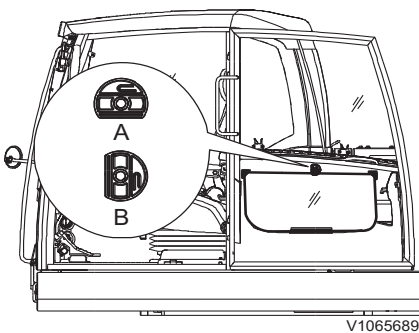

Locking handle for lower window

A Unlock position

B Lock position

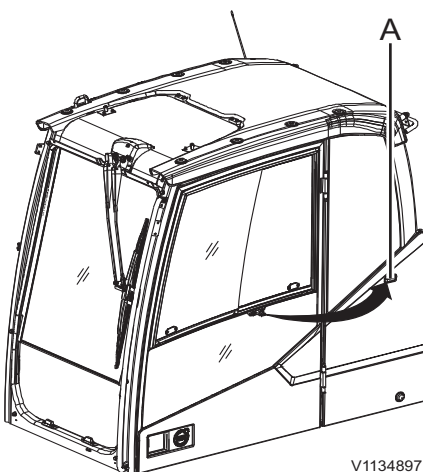

### Door

Door lock (A) is used to keep the cab door secure in the open position.

- 1 Push the door against outside of the cab.
- 2 Ensure it is securely fixed to the lock (A)

Press the lever (B) inside the cab to release the door.

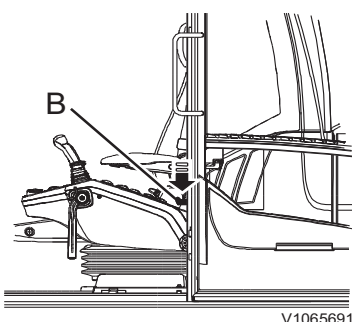

120 Other controls  
Operator comfort

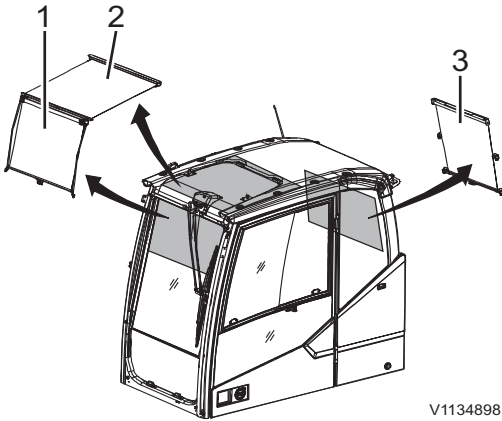

V1134898

- 1 Front sun shade
- 2 Roof sun shade
- 3 Rear sun shade

## Sun shade

Use the front, roof and rear sun shades to protect from the sun light coming in through windows.

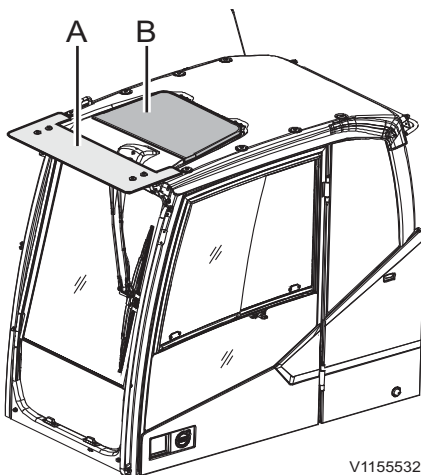

V1155532

- A Rain shield
- B Sun shield

## Rain shield

(optional equipment)

A rain shield prevents rain from falling on the operator's feet when windshield is open.

### **NOTICE**

With certain attachment combinations there is a risk that the attachment may strike the cab. Avoid damage by being careful when working close to the machine.

## Sun shield

(optional equipment)

A sun shield on the roof reduces incoming light and heat radiation further.

When installing the sun shield roof, consider other optional equipments, for example, rain shield, anti-vandal kit and so on.

## Hour meter

The hour meter shows the total number of hours the engine has operated. It records the hour only when the engine is running.

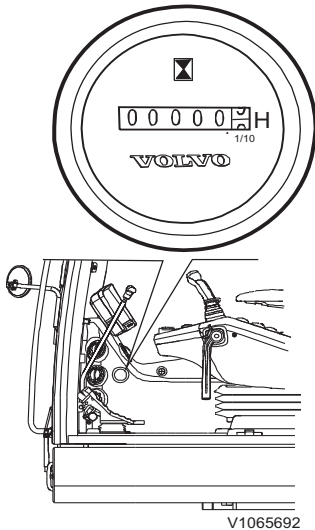

## Roof

### Roof hatch, open

- 1 Grip the handle (1) and turn it to open direction (2).
- 2 Open the roof (3).

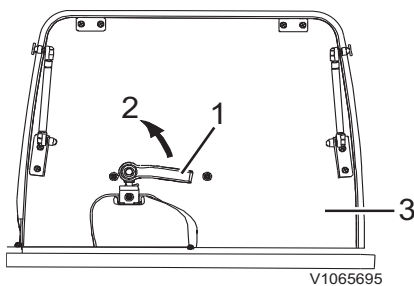

- 1 Handle
- 2 Open direction
- 3 Roof hatch

### **NOTICE**

The roof hatch must be securely locked when transporting.

### **NOTE!**

Cab with fixed roof hatch is provided as an optional equipment. In this case, there is no handle and gas spring.

122 Other controls  
Operator comfort

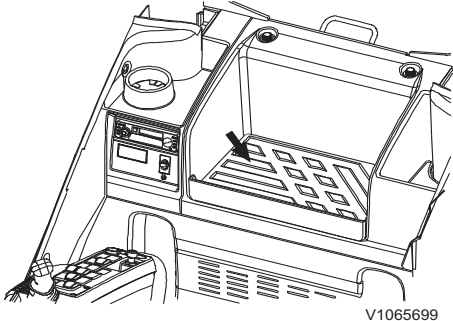

V1065699

### Storage compartment

A storage compartment is located at the rear side of operator seat.

**NOTE!**

Do not store tools in the storage compartment. This could damage the compartment.

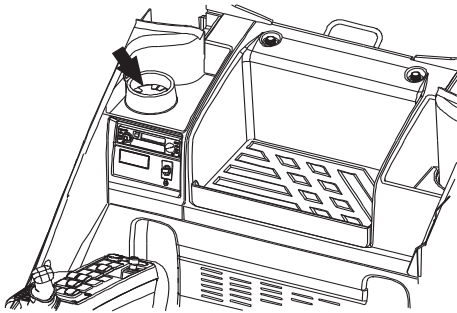

V1065697

### Cup and drink holder

Use the cup and drink holder to hold a soft drink can in place.

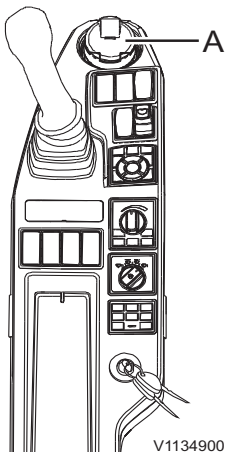

V1134900

### Ashtray (optional equipment)

Pull the top edge of the ashtray (A) in order to open it.

Pull the ashtray upward out of the console when cleaning it.

**NOTE!**

Make sure that you close the ashtray after use in order to prevent any possibility of fire.

**NOTE!**

The ashtray can be put into the cup and drink holder.

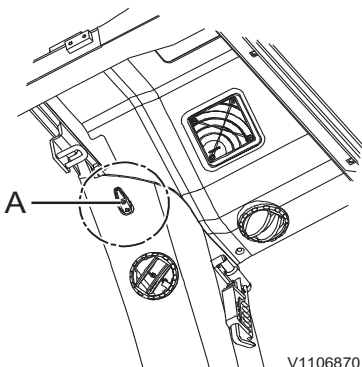

V1106870

### Coat hook

The coat hooks (A) are inside the cab.

**NOTE!**

Do not hook any item that may obstruct the view of the operator.

## Operator's manual, storage

Operator's manual storage is located at the backside of seat. Keep the manual in the storage so that it is always at hand.

## Fire extinguisher, location

(optional equipment)

Mount fire extinguisher as follows, Remove two screws inside of caps (1) installed on the rear side in a cab and then install the fire extinguisher.

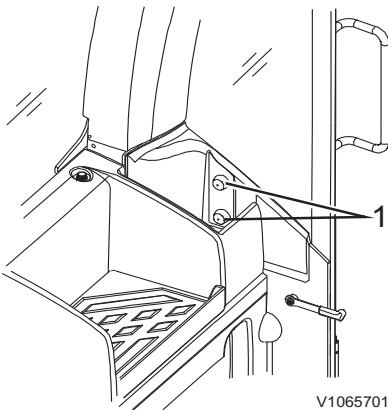

V1065701

## Emergency exit

The cab has two emergency exits, the door and the rear windshield.

Regardless of the rear windshield types, break the glass with the hammer attached on the rear side in a cab.

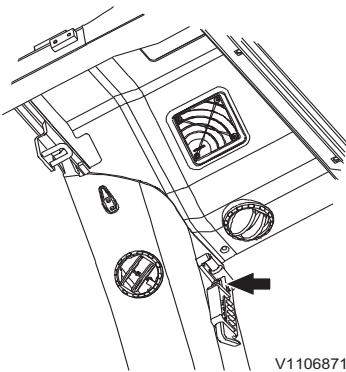

V1106871

Hammer

### **NOTICE**

The hammer must not be removed from its position or be used at other occasions than in an emergency situation. If the hammer should be lost, it must be replaced immediately.

### **NOTICE**

There is a knife on the hammer for the emergency exit. Cut off the seat belt with the knife, if the buckle cannot be undone.

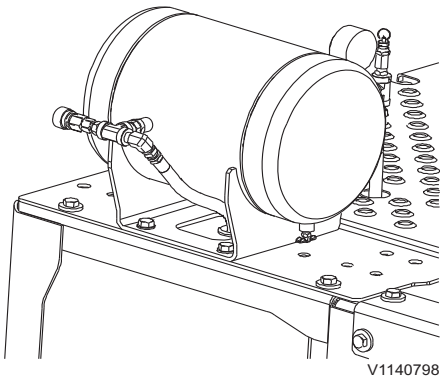

Air compressor tank

## Air compressor

(optional equipment)

The air compressor is used primarily to clean the dust from inside the cab, and the engine air cleaner.

- 1 Press the air compressor switch to ON position to operate the compressor, see page 79.

### NOTE!

When the tank pressure of the compressor is under 0.74 MPa (7.5 kgf cm<sup>2</sup>) (107 psi), the compressor works. However, when the tank pressure is 0.98 MPa (10 kgf cm<sup>2</sup>) (142 psi) or the motor has run over 20 minutes, the compressor shuts down.

- 2 Clean out the dust with the air gun.

### NOTE!

The air gun and hose are stored inside the cab.

## Caution for operation

- Never use compressed air for cleaning clothes or persons.

## WARNING

Risk of serious injury.

Compressed air, water jets or steam may cause damage to unprotected skin and eyes.

**Always wear personal protective gloves, goggles and clothing when using compressed air, water jets or steam.**

- Do not touch the surface of compressor while it is running. The case temperature can reach about 130°C.
- Bleed the air in the tank after using the compressor.
- Do not disassemble and modify the compressor.
- Do not use the compressor extensively in humid areas or on rainy days.





## Audio system

### 1 Radio setting method by region

- Europe: Press the AM/FM button, and then press preset 6 for 2 seconds.

#### **NOTE!**

Setting is completed when "EU" message is shown.

- North America: Press the AM/FM button, and then press preset 1 for 2 seconds.

#### **NOTE!**

Setting is completed when "NA" message is shown.

- Others: Press the AM/FM button, and then press preset 5 for 2 seconds.

#### **NOTE!**

Setting is completed when "INT" message is shown.

### 2 Tuning ranges

	Band	Frequency
<b>Europe</b>	FM	87.50 ~ 108.00 MHz
	AM (MW)	531 ~ 1629 KHz
	LW	144 ~ 288 KHz
<b>North America</b>	FM	87.50 ~ 108.00 MHz
	AM	530 ~ 1710 KHz
<b>Others</b>	FM	87.50 ~ 108.00 MHz
	AM	531 ~ 1629 KHz



126 Other controls  
Operator comfort

Radio and USB-MP3 Player (optional equipment)

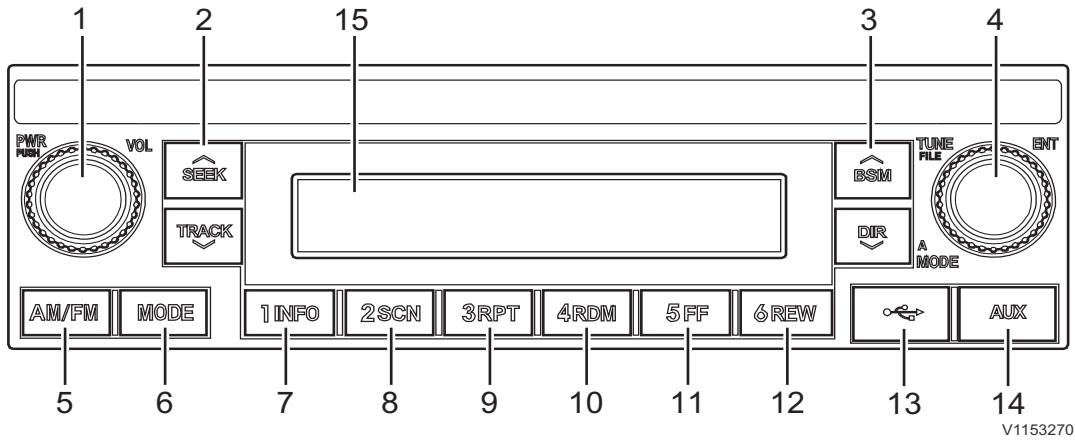

V1153270

1	Power and Volume	9	Preset 3 / Repeat
2	Seek and Track	10	Preset 4 / Random
3	BSM and DIR	11	Preset 5 / Fast Forward
4	Tune, A mode, and File	12	Preset 6 / Rewind
5	AM / FM	13	USB
6	Mode	14	AUX
7	Preset 1 / Info	15	LCD panel
8	Preset 2 / Scan		



■ **Power and Volume setting button (1)**

- Power button  
Press the power button to turn on the audio system. While the audio is operating, press the button to turn off the power.
- Volume button  
Turn the volume button clockwise to increase the volume and counter-clockwise to decrease the volume.

■ **SEEK and TRACK button (2)**

- Broadcast automatically search button (SEEK / TRACK)  
The buttons are used to automatically search for broadcasts, pressing the button will automatically search and stop at a frequency with the best reception.  
SEEK: Searches frequencies higher than current frequency  
TRACK: Searches frequencies lower than current frequency
- Track up / down button (SEEK / TRACK)  
While playing a USB-device, press the SEEK button to play the beginning of the next song. Press the TRACK button to return to the beginning of the current song. Press the button again to play the beginning of the previous song.

■ **BSM and DIR button (3)**

- Best Station Memory button (BSM)  
Press the BSM button to automatically save frequencies with the best reception in presets (1 INFO ~ 6 REW).
- Directory up / down button (BSM / DIR)  
If there are more than 2 folders in the USB-device, pressing the BSM up / DIR down button will move to the previous or next directory. If there are no folders in the USB-device, then pressing the button will move up / down within the folder in 10 file increments.



■ **TUNE, A MODE, and FILE button (4)**

- Broadcast manual search button (TUNE)

The button is used to search for frequencies manually, a tune of the SEEK STEP will change the frequency.

Turn the button clockwise to increase the frequency and counter-clockwise to decrease the frequency.

- Sound setting button (A MODE)

Press the sound setting (A MODE) button to set sound.

Each press of the button will change the sound setting in the following order.

BASS → MIDDLE → TREBLE → BALANCE → FADER → LOUD

After selecting the desired setting, turn the sound setting (A MODE) button clockwise / counter-clockwise to adjust the sound setting value.

- Finding and Playing file (FILE)

While a USB-device is playing, turn the FILE button left / right to find the desired song and press the FILE button to play.

■ **Radio select (AM / FM) button (5)**

- Each press of the AM / FM button will change the radio mode in the following order.

FM1 → FM2 → AM → FM1



- 
- **MODE select button (6)**  
 Press the MODE button to change to RADIO / USB / AUX modes.

    - USB select button  
 While playing a different mode, press the MODE button to convert to USB mode. Connecting a USB-device to the audio system will automatically convert to USB mode even if another mode is playing and then songs on the USB-device are played automatically.
    - AUX select button  
 While playing a different mode, press the MODE button to convert to AUX mode. Connecting your portable media player to the audio system will automatically convert to AUX mode even if another mode is playing and then songs on the portable media player are played automatically.
  - **PRESET buttons (7, 8, 9, 10, 11, and 12)**  
 Select the preset button (7, 8, 9, 10, 11, and 12) to which you want to save the selected frequency. Press and hold the preset button. The frequency will be saved to the preset button to the sound of a beep. The saved frequency number will be displayed on the LCD panel.
  - **INFO button (7)**  
 Each time the INFO button is pressed, the info on the currently playing song will be displayed in the following order.  
 File Name → Folder Name → Title Name → Artist Name → Album Name → Play Time
  - **Scan and Directory scan button (8)**  
 While music is playing, press briefly on the SCN button to scan each song within the current directory for 10 seconds in sequential order. While music is playing, press and hold the SCN button to scan each song in the USB-device for 10 seconds in sequential order.

■ **Repeat and Directory repeat button (9)**

While music is playing, press briefly on the RPT button to repeat the currently playing song.

Press and hold the RPT button to sequentially repeat all songs within the current directory.

(However, for Directory RPT, music files in the USB-device must be saved in directory format.)

■ **Random and Directory random button (10)**

While music is playing, press briefly on the RDM button to randomly play the songs in the current directory.

While music is playing, press and hold the RDM button to randomly play all songs in the USB-device.

■ **Fast forward button (11)**

While a USB is operating, press and hold the FF button to fast-forward the song. When fast-forward is complete, the next song will play from the beginning even if you continue holding the button. Pressing the button briefly will not operate FF.

■ **Rewind button (12)**

While a USB is operating, press and hold the REW button to rewind the song. When rewind is complete, the current song will play from the beginning even if you continue holding the button. Pressing the button briefly will not operate REW.

■ **USB-connector (13)**

It is the connector for direct connection of a USB-device. Connecting a USB-device to the audio system will play the songs on the USB-device.

**NOTE!**

When using an external USB-device, make sure to keep the device disconnected and connect only some time after turning on the vehicle's ignition switch. The USB-device may be damaged if the USB-device already is connected when the ignition switch is turned on. (A USB-device is not an electric automotive part.)

■ **AUX-connector (14)**

It is the connector for connecting your portable media player using an AUX cable. AUX cable is not supported.

**NOTE!**

The device will not operate when playing a format which is not MP3 or WMA file formats.

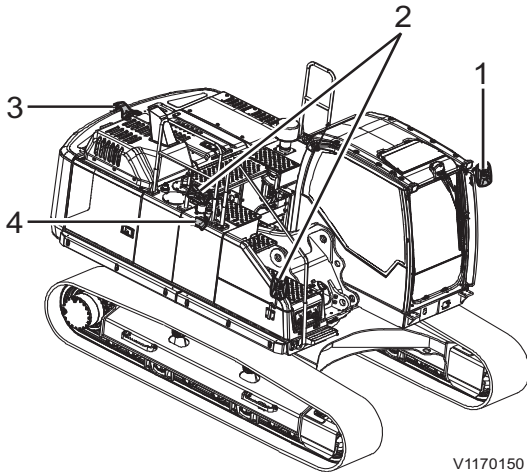

V1170150

Mirrors and cameras (if installed)

## Vision system

The machine has a lot of equipment for the operator to minimize visibility hazards. Using this equipment, the operator must always ensure good visibility of the surroundings when operating the machine.

- 1 Left mirror
- 2 Right mirrors

### NOTE!

Right mirrors are used as aids for better visibility.

- 3 Rear-view camera
- 4 Side-view camera

### NOTE!

Any modifications done to the machine that affect the operator's visibility must be verified by a Volvo dealer.

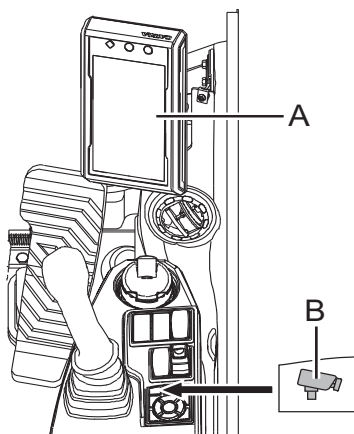

V1151952

## Camera system (if installed)

The camera screen in the IC (Instrument Cluster) (A) is shown if any condition of below is met:

- by pressing the camera button (B) on the keypad or
- when operating any control lever (joystick) / pedal or
- without keypad signal during 10 seconds.

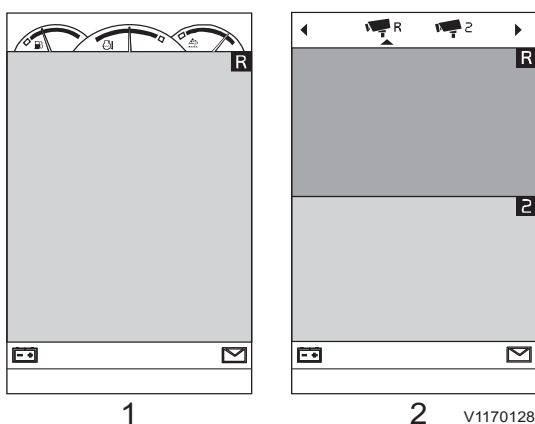

V1170128

- 1 Camera view with gauges
- 2 Camera view with configuration bar

- A short press on the camera button shows the camera view with gauges (1):  
This camera view (1) shows the camera screen (depending on the selected configuration) with the fuel level, engine coolant temperature, and AdBlue®/DEF level.
- A long press on the camera button shows the camera view with configuration bar (2):  
This camera view (2) shows the camera screen with the camera configuration bar at the top. The camera configuration bar is used to show or hide camera views on the IC (Instrument Cluster). Press the camera button (B) on the keypad to rotate the camera views clockwise. Select one of the camera icons and press SELECT on the keypad to show or hide this camera view.

132 Other controls  
Operator comfort

---

**Rear-view camera (if installed)**

The rear-view camera (C) is installed on top of the counterweight.

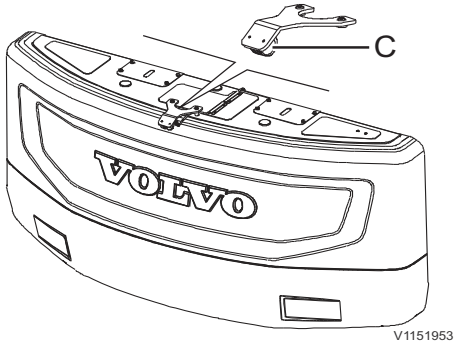

**Side-view camera (if installed)**

The side-view camera (D) is installed on the guardrail on the machine's right side.

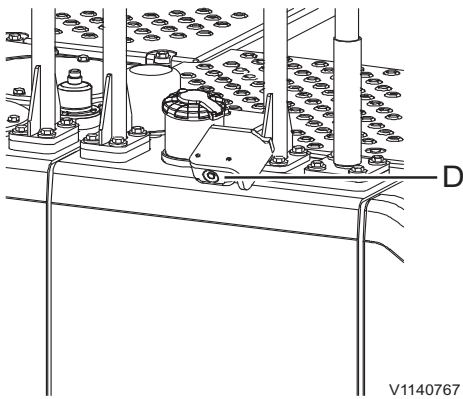

## Volvo Smart View

### (Optional equipment)

Volvo Smart View (VSV) shows a real-time, overhead view of the machine during operation. This system helps your visibility and to see all angles (360°).

#### NOTE!

Volvo Smart View is a synthetic view which is intended to be used as a convenient vision-assist system. Always check visually around the machine, especially the stitching areas, to be sure.

#### NOTE!

A Volvo dealer may have to perform a VSV-calibration if any installed camera position is changed.

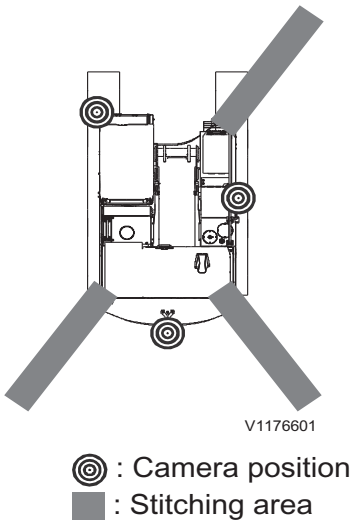



134 Other controls  
Operator comfort

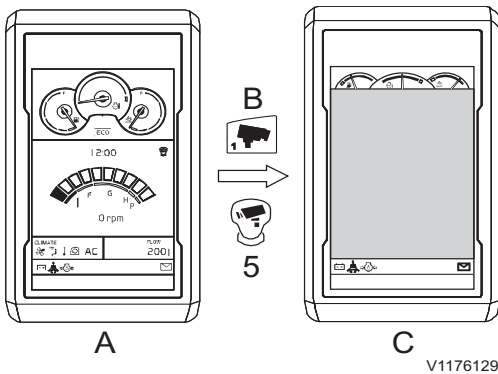

- A Main screen of IC
- B Camera button on keypad
  - **Short press:** VSV-screen
  - **Long press:** VSV-configuration
- C Volvo Smart View screen

If the camera button (B) or joystick shortkey (5) is pressed briefly: single view is shown according to the view sequence below. Press the button (B) or (5) until the desired view is shown.

**Split-view<sup>(1)</sup> → Top view 1 (long range view) → Top view 2 (short range view) → Side mirror view → Rear view → Right side view → Off**

- **Top view 1 (long range view):** synthetically created allround view generated from the installed cameras. This view could be used for checking objects/people at relatively long distance around the machine.
- **Top view 2 (short range view):** synthetically created allround view generated from the installed cameras. This view could be used for checking objects/people near the machine
- **Side mirror view:** Left and right mirror view are also displayed on **Top view 1**. This view could be used for checking objects/people to the side of the machine (especially stitching areas).
- **Rear view:** this view is only transmitted by the rear view camera.
- **Right side view:** this view is only transmitted by the right side view camera.
- **Off:** turn OFF the VSV-system. Main screen is displayed on IC.

**NOTE!**

Always turn on the camera view(s) when operating the machine. For more information, see page 43 and 131.

1. this view can be displayed when presetting is done

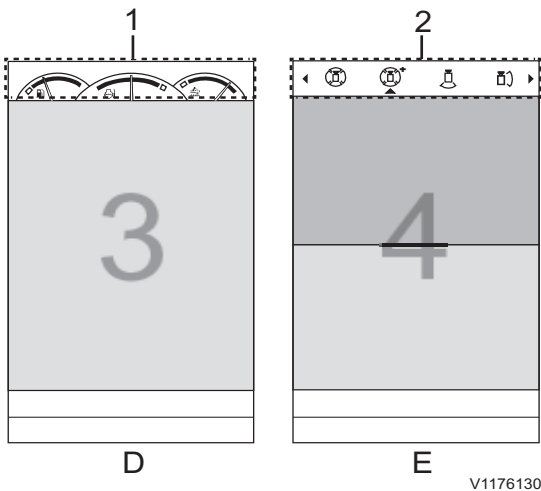

D VSV-screen  
E VSV-configuration screen

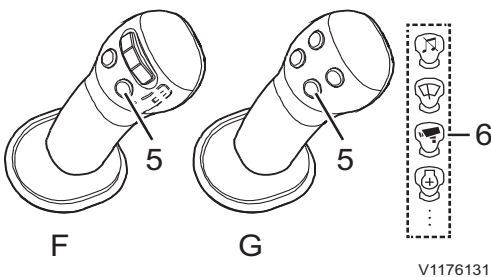

**Shortcut (multifunctions) button (5) on left lever**

- F Proportional switch type
- G Four-button type

If the camera button (B) is pressed for more than 1 second:  
configuration bar (2) is shown. Select two types of views with 4 icons.

**Split-view setting**

- Top view 2 (short range view) ↔ Side mirror view ↔
- Rear view ↔ Right side view

**NOTE!**

The displayed gauges (1) can be different according to machine type.

**NOTE!**

VSV-system supports single view (3) among five views or split-views (4) within **Top view 2**, **Mirror view**, **Rear view** and **Right side view**.

VSV can be turned ON using the shortcut button (5) if this button is assigned to the camera function (6). For more information about joystick shortcut, see page 43. (**MENU** → **Setup** → **Joystick shortcut** → **Camera**)

If necessary, an additional camera may be installed according to user need. In this case, the VSV-system can be turned ON using camera button (B) on the keypad. An additional camera view is only shown using joystick shortcut button (5). (**MENU** → **Setup** → **Joystick shortcut** → **Extension camera**)

**NOTE!**

According to machine options, an extension camera can not be installed. Contact an authorized Volvo dealer to install an extension camera and for additional information.

## Auxiliary heater

### (Optional equipment)

Check which of the two auxiliary heater control unit versions is installed in your machine.

The auxiliary heater is used for heating the engine coolant by a fuel combustion unit while the engine is stopped. It consists of the fuel tank, fuel pump, water pump, the timer and the heating unit. The auxiliary heater facilitates the engine start and heating the cab in severe cold weather.

The heated coolant is circulated through the engine block → water pump → auxiliary heater → heater core → engine block.

The auxiliary heater timer can be used to make the necessary settings for operation of the heater.

### Button functions

If the display is not lit the timer must be activated. SHORTPRESS on one of the four buttons, the start display appears in the display, then continue with the operation or setting.

All functions can be set and, if necessary, changed with only 4 buttons.

#### 1 Power on / confirm button

##### ■ SHORTPRESS button

- if the display shows OFF → Timer On, the start display appears.
- A selected function is confirmed.
- Inputs are confirmed.

##### ■ LONGPRESS button : The button must be pressed for longer than 2 seconds.

- The heater is switched on immediately if On or OFF appears in the display.

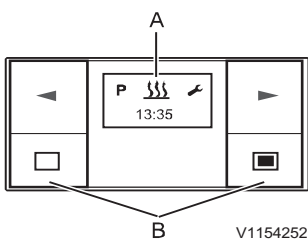

A Display window  
B Buttons

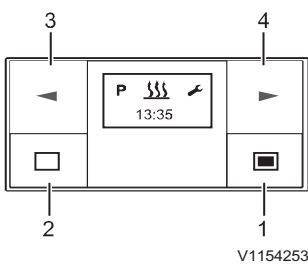

- 1 Power on / confirm button
- 2 Power off / cancel / exit setting button
- 3 Backward button
- 4 Forward button

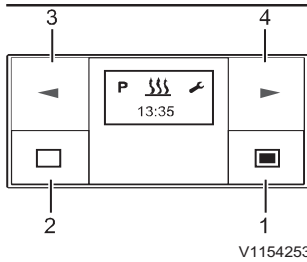

- 1 Power on / confirm button
- 2 Power off / cancel / exit setting button
- 3 Backward button
- 4 Forward button

## 2 Power off / cancel / exit setting button

### ■ SHORTPRESS button

- The displayed, activated function is ended, other activated functions are retained.
- With each SHORTPRESS the display changes to a next-higher level up to Timer OFF.
- The start display appears and no function is active: → Timer OFF.
- Timer is in submenu → the setting is exited, already set values are not saved.
- If the display shows OFF → Timer On, the start display appears.

### ■ LONGPRESS button : The button must be pressed for longer than 2 seconds.

- All functions are ended.
- If the display shows OFF → Timer On, the start display appears.

## 3 Backward button

- Timer is in the Main menu and the start display appears → in the Menu bar the next, left-hand symbol appears in the middle and flashing.
- Timer is in the submenu → the displayed value is changed (smaller), or the next selection is displayed.
- If the display shows OFF → Timer On, the start display appears.

## 4 Forward button

- Timer is in the Main menu and the start display appears → in the Menu bar the next, right-hand symbol appears in the middle and flashing.
- Timer is in the submenu → the displayed value is changed (larger), or the next selection is displayed.
- If the display shows OFF → Timer On, the start display appears.

138 Other controls  
Operator comfort



V1154254

Main menu  
A Menu bar  
B Status area



V1154255

Submenu  
A Menu bar : activated function  
B Input area



V1154256

Operation and setting/adjustment

Main menu

Menu bar

The following menu items can be selected.

Symbol	Function
	Heating ON / OFF
	Settings
<b>P</b>	Program / Preselection

Status area

If no menu item is activated, the current time is displayed in the status area.

If a menu item is activated (heating, settings or program / preselection), different information is displayed in the status area.

Submenu

In the submenu, the symbol of the selected menu item appears in the middle of the display. The corresponding set value is displayed flashing in the entry area and can be set using the Backward button (3) or Forward button (4) and confirmed with the Confirm button (1).

Start display after switching ON

if no menu item is activated, the start display appears with a flashing heater symbol in the Menu bar, with the current time in the status area.

Other possible actions are:

- Heating immediately with LONGPRESS button (1).
- Heating on with SHORTPRESS button (1), in addition confirm and set the operating time.
- Select a new menu item.



V1154257



V1154258

### 1 Heating ON / OFF

#### ■ Heating immediately with LONGPRESS (without settings)

- 1 Press the LONGPRESS button (1) for longer than 2 seconds.
- 2 Screen shows remaining operating time.
- 3 If LONGPRESS is pressed during heating mode, the display switches to the heating submenu set and set operating time. During heating mode it is possible to switch to another menu item.

#### ■ Heating on with SHORTPRESS and with settings

- 1 Press the SHORTPRESS button (1) for less than 2 seconds.

#### NOTE!

The following settings and confirmations (operating time) are always required.

- 2 If necessary, use the BACKWARD or FORWARD button to set the operating time. Press the confirm button (1) to confirm the operating time.

#### ■ Heating OFF

- Press the button (2) for longer than 2 seconds. → all active functions are ended.
- Press the button (2) for less than 2 seconds. → heater OFF.

After the heating off the start display appears. if the vehicle lighting is off the display lighting goes out after 10 seconds.

#### The following actions are possible during the heating off display:

- Use the forward or backward button to select a menu item. Press the SHORTPRESS button (2), the start display appears.
- Press the SHORTPRESS button (1), the heating submenu is displayed.

140 Other controls  
Operator comfort

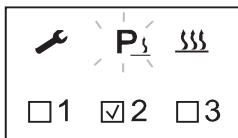
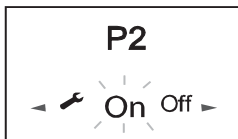
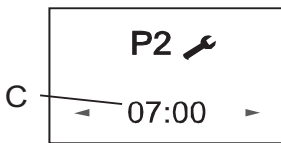
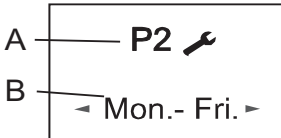
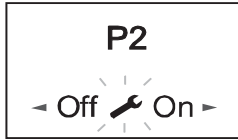
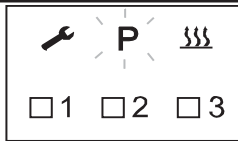

V1154261

- A Preset unit
- B Preset day
- C Departure time
- D Operating time

2 General information on programming the preset time

Timer can be used to program 3 preset times. The 3 preset times can either all take place on one weekday or can be distributed between different weekdays. 3 weekday ranges are available to choose from, these can each be started daily with a preset time.

■ Weekday ranges:

- Day: Once
- Sat-Sun: 2x Heating
- Mon-Fri: 5x Heating
- Mon-Sun: 7x Heating

- If the system is activated with programmed weekday range, all weekdays are worked through consecutively; after that renewed programming is required.
- If the timer with a programmed weekday range Mon – Fri is activated on Wednesday, the heater heats on Thursday and Friday, the heater is not operated on Saturday and Sunday. From Monday to Wednesday of the following week the operation is continued with the set defaults (5x heating). After a weekday range has been worked through renewed programming is required.

■ Departure time operating mode (factory setting)

Under the following conditions the preselected heating mode is not started on the current day.

- The current day and the preselected day are identical.
- The current time lies within the time period, departure time minus operating time.



**Example:**

Current day / preselected day: Mon

Current time: 06:45

Departure time: 07:00

Operating time: 60 minutes

Duration: 06:00 to 07:00

The current time lies within the time period, the heater is not switched on.

The program will be run during the next week.

■ **Program preset times**

- 1 Use the backward or forward button to select the Program symbol in the menu bar.
- 2 Confirm the Program menu by pressing the confirm button (1).

If the Program symbol is marked with **P**, a or several program memories is/are already activated.

Activated program memories are marked in the display with a .

3 Settings

This function is for setting current day and time.

- 1 Use the backward or forward button to select the setting symbol in the menu bar.
- 2 Confirm the setting menu by pressing the confirm button.
- 3 Use the backward or forward button to select the submenu which want to change the setting.
- 4 Press the confirm button to confirm the setting value.

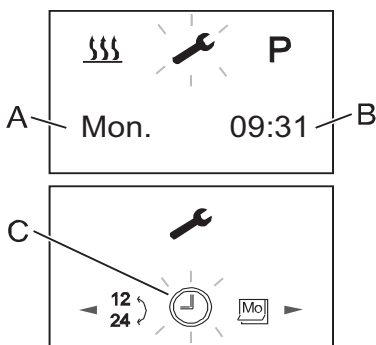

V1154262



- A Current day
- B Current time
- C Settings submenu bar



142 Other controls  
Operator comfort

**Error messages**

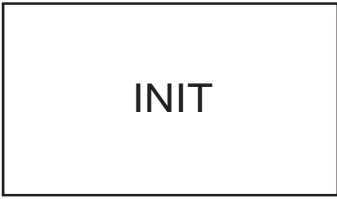
In the event of a fault the following displays are possible:

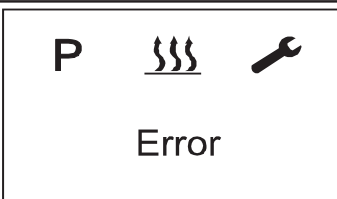
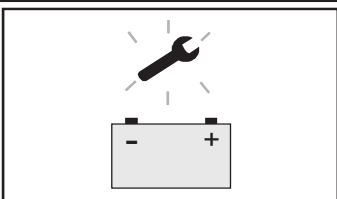
Display	Description	Remedy
 <p>V1154443</p>	<ul style="list-style-type: none"> <li>- Automatic detection is active.</li> <li>- The auxiliary heater timer has been disconnected from the power supply and then reconnected.</li> </ul>	<p>Wait until the automatic detection has finished, then set the time and weekday.</p>
 <p>V1154444</p>	<ul style="list-style-type: none"> <li>- No communication.</li> </ul>	<p>Check and if necessary renew the heater fuse. Contact a workshop authorized by Volvo.</p>
 <p>V1154445</p>	<ul style="list-style-type: none"> <li>- Heater fault.</li> </ul>	<p>Contact a workshop authorized by Volvo.</p>
 <p>V1154447</p>	<ul style="list-style-type: none"> <li>- Voltage too low.</li> </ul>	<p>Charge battery, if necessary contact a workshop authorized by Volvo.</p>

**NOTE!**

If you are unable to remedy the error or fault, contact a workshop authorized by Volvo.



### Winter season preparation for auxiliary heater

Operator should exhaust remaining summer diesel in fuel line of auxiliary heater before winter season comes. Remaining summer diesel can cause plugging in fuel line if temperature drops in sudden because of wax crystallization. Run auxiliary heater at least 15 minutes until remaining diesel is exhausted.

When operator runs machine in winter season, it is recommended to fill fuel tank over 70%. If fuel tank has much empty space, it makes moisture inside of fuel tank. It can go to fuel line of auxiliary heater and frozen moisture sometimes makes fuel feeding problem.

### Fuel quality requirements for auxiliary heater

If the heater is run from a separate fuel tank, comply with the following rules.

- If ambient temperatures over 0 °C;  
Use diesel fuel according to DIN EN 590.
- If ambient temperatures from 0 °C to -20 °C;  
Use winter diesel fuel according to DIN 590.
- If ambient temperatures from -20 °C to -40 °C;  
Use Arctic diesel or Polar diesel.

#### NOTE!

- Used oil is not allowed.
- After refuelling with winter or cold diesel or the listed blends, the fuel pipes and the metering pump must be filled with the new fuel by letting the heater run for 15 minutes.
- Volvo does not recommend mixing Kerosene with diesel due to unstable combustion which causes decrease of durability of auxiliary heater and makes bad exhaust gas.
- Volvo recommends to use commercial additives which improve wax crystallization of diesel fuel in cold weather if it is difficult to use Arctic diesel or Polar diesel.



### Operation with bio-diesel fuel

The heater is approved for operation with bio-diesel up to a temperature of -8 °C (the flowability reduces at temperatures below 0 °C).

#### NOTE!

- If operated with bio-diesel (100% operation and blends), the heating output of the heater reduces.
- A reduced heater life is to be expected if constantly operated with 100% bio-diesel.
- Standard diesel fuel contains up to 20% bio-diesel. This does not have any effect on the life of the heater.

Contact a workshop authorized by Volvo for detailed information.

## Auxiliary heater

(Optional equipment)

### WARNING

Risk of fire and explosion.

A running auxiliary heater in the immediate vicinity of flammable gases, fumes, liquids or dust could cause fire and explosion.

**Do not use the auxiliary heater if the machine is in an environment in which flammable gases, fumes, liquids or dust are present or could be present.**

### DANGER

Risk of suffocation.

Exhaust fumes from the auxiliary heater contain carbon monoxide, a colorless, odorless gas, which is fatal when inhaled in a confined area.

**Do not use the auxiliary heater if the machine is located in enclosed rooms without proper ventilation.**

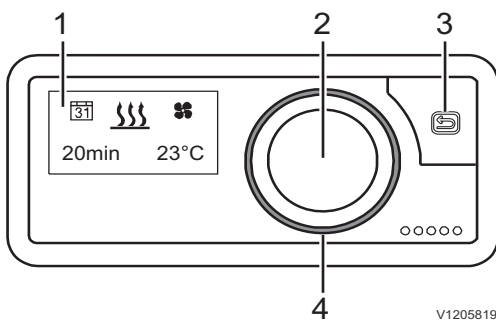

- 1 Display
- 2 Operating button
- 3 BACK button
- 4 LED ring

The auxiliary heater timer is used to select the operation mode, for setting the operating time, for preselecting the starting time and for switching the heater ON or OFF.

#### 1. Display

The display shows the following parameters:

- Current operating mode
- Current interior temperature
- Operating mode
- Timer positions
- Settings
- Error messages



## 2. Operating button

The operating button is used to operate, select and program all the functions and values in the auxiliary heater timer.

**Turning** selects a value/function within a menu.

- Turning to the right increases a value or selects the next menu item to the right.
- Turning to the left decreases a value or selects the next menu item to the left.
- If the timer is in sleep mode (display OFF), pressing or turning “wakes up” the active display mode.

If the heater is switched off, the Start mask will be displayed.

- When the heater is running, the currently remaining operating time of the heater is displayed.

### NOTE!

- A LONGPRESS (minimum 2 seconds) immediately starts the heater. The standard operating time is set at the factory to 30 minutes.
- During operation, a LONGPRESS (minimum 2 seconds) immediately switches off the heater.

## 3. BACK button

The BACK button causes a jump back to the menu or command at the next higher level. If the timer is in sleep mode (display OFF), pressing “wakes up” the active display mode.

- If the heaters is switched off, the Start mask will be displayed.
- When the heater is running, the currently remaining operating time of the heater is displayed.

## 4. LED ring

The LED ring indicates the different operating modes with different colors.

- Red ring: Heating mode
- Blue ring: Ventilation mode
- Orange ring: Residual heat mode
- White ring: System configuration
- Red flashing ring: Fault in the heater or in the timer.

## Operation and settings

### Activating the timer

If the display is not lit, the timer has to be activated. Pressing the operating button or BACK button  displays the Start mask.

### Display

The display is lit:

- During operation of the timer
- When the heater is ON (the display goes out after approx. 30 seconds).

Display goes out:

- No settings are made.
- No heater is switched on.

The timer then goes to sleep mode. Before going to sleep mode, an overview mask is displayed. The timer has to be activated (see above) before a new input can be made.

### Activating a function

The symbol of the function to be activated appears in the middle and flashes in the display.

Flashing function / flashing value

- Select the flashing function in the menu bar by pressing the operating button.
- Increase or decrease the flashing value by turning the operating button. Then confirm the selected value by pressing the operating button.

### Cancel settings

Any settings being made can be cancelled with the BACK button .

### NOTE!

Settings and changes must always be confirmed by pressing the operating button, otherwise they will be lost.

### Setting the operating time

The operating time can be set individually using the operating button.

- Turning to the right increases the operating time.
- Turning to the left decreases the operating time.
- Setting range for the operating time:  
minimum 10 minutes to maximum 120 minutes in one minute steps.

148 Other controls  
Operator comfort

- The operating time can be prolonged to infinite. Above the 120th minute, the input is made in 60-minute steps.

**Operating modes**

**Heating mode**

In this mode, the heater heats the vehicle engine via the coolant circuit and the cab via the HVAC system (Heating, Ventilation, Air Conditioning).

**Ventilation mode**

In this mode, the heater supplies the cab with fresh outdoor air via the HVAC system (Heating, Ventilation, Air Conditioning).

**Residual heat mode**

In this mode, the heating system uses the residual heat in the coolant circuit of the warm engine and distributes heated air in the cab.

**Menus and functions**

**Menu Bar**

The following menus can be selected from the menu bar (turn the operating button to the right):

Symbol	Function
	Heat
	Ventilate
	Residual heat
	Settings
	Timer

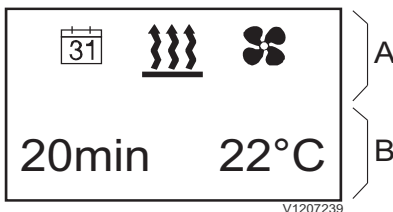

- A Menu bar
- B Status area

**Status area**

When the menu (heating, ventilation, settings, timer or residual heat) is activated, various items of information are displayed in the status area.

**Input area**

In the menu bar, the symbol of the selected menu item appears in the middle of the display. The corresponding setting value flashes in the input area and can be altered by turning the operating button to the left or right and confirmed by pressing.

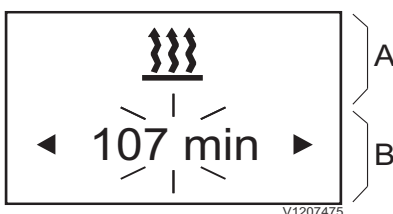

Example: Heating ON, operating time 107 minutes

- A Menu bar
- B Input area

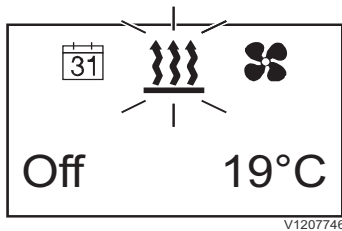

Start mask, heating

### Heating

In the Start mask, a flashing heater symbol in the menu bar and the current temperature and status of the heater are displayed.

Possible actions are:

- Heating immediately with LONGPRESS
  - Press operating button for longer than 2 seconds.
  - Heating mode starts immediately with the last operating time used. The LED ring lights up red and the residual heating mode time is displayed.

#### NOTE!

The function LONGPRESS ON is not available in ventilation and residual heat mode.

- Heating ON with settings
  - Press the operating button.
  - Select the operating time by turning the operating button.
  - Confirm the operating time by pressing the operating button.
  - Heating mode starts with the set operating time. The LED ring lights up red, the residual heating time and the current temperature are displayed.
  - Heating mode ends at the end of the set operating time.

Changing the operating time during heating mode:

- Press the operating button.
- Select and confirm flashing menu
- Select and confirm the settings by turning and pressing the operating button.
- Set the desired operating time by turning and press to confirm.
- Heating mode is continued with the set operating time. The LED ring lights up red and the residual heating mode time is displayed.

HEATING OFF during heating mode:

- Press the operating button.
- Select and confirm flashing menu .
- When OFF flashes on the display, press the operating button again.
- Heating mode is terminated.

#### NOTE!

LONGPRESS terminates heating mode immediately and the heater is also switched off.



150 Other controls  
Operator comfort

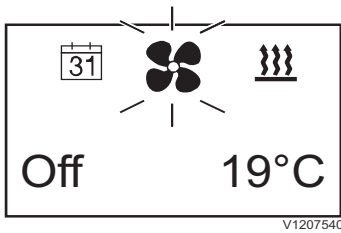



Start mask, ventilation

### Ventilation

In the Start mask, a flashing fan symbol  in the menu bar and the current temperature and status of the heater are displayed.

- Press the operating button.
- Select the operating time by turning the operating button and confirm, or confirm the displayed operating time.
  - Ventilation mode starts with the set operating time. The LED ring lights up blue and the residual ventilation mode time is displayed.
- Ventilation mode ends at the end of the set operating time.

Changing the operating time during ventilation mode:

- Press the operating button.
- Select and confirm flashing menu .
- Select and confirm the settings  by turning and pressing the operating button.
- Set the desired operating time by turning and press to confirm.
  - Ventilation mode is continued with the set operating time. The LED ring lights up blue, the residual ventilation mode time and the current temperature are displayed.

Ventilation OFF during ventilation mode:

- Press the operating button.
- Select and confirm flashing menu .
- When OFF flashes on the display, press the operating button again.
- Ventilation mode is terminated.

### **NOTE!**

LONGPRESS terminates ventilation mode immediately and the heater is also switched off.

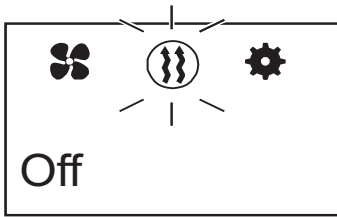

V1207541

Start mask, residual heat

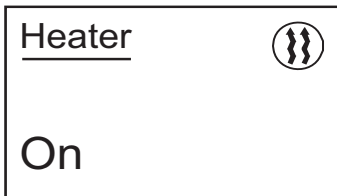

V1207542

Residual heat mode ON

### Residual heat mode

In the Start mask, a flashing heater symbol in a circle (ii) in the menu bar and the current status of the heater are displayed.

In the residual heat mode, the heating system uses the residual heat in the coolant circuit of the warm engine and distributes heated air in the cab.

In this operating mode, only the water pump and fan are in operation.

#### **NOTE!**

Residual heat mode cannot be used if the coolant temperature is too low.

#### Residual heat mode ON

- Press the operating button and select ON.
  - Residual heat mode starts if there is residual heat in the engine coolant.
  - The LED ring lights up orange. The operating time of the heating mode depends on the available residual heat.
  - The operating status and mode of the heater appear on the display.

#### Residual heat mode OFF

- Press the operating button and select OFF.
  - Residual heat mode stops.

#### **NOTE!**

LONGPRESS stops the residual heat mode immediately.

## 152 Other controls Operator comfort

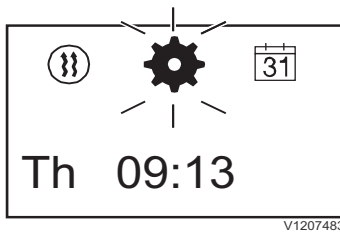

Start mask, settings

### Settings

In the Start mask, a flashing gear wheel  in the menu bar and the set day of the week and the current time are displayed.

Possible actions are:

- Standard settings for day of the week, time and temperature format
- Heating at high altitudes: ON / OFF
- Low temperature during heating: ON / OFF
- Fault diagnosis: Display of error messages
- Reset user settings

### Standard settings

Set time:

-  Select and confirm.
- Set the hours and confirm.
- Set the minutes and confirm.

Set time format:

-  Select and confirm.
- Select between 12 h and 24 h format and confirm.

Set weekday:

-  Select and confirm.
- Set the day of the week and confirm.

Set temperature format:

-  Select and confirm.
- Select between degrees Celsius and degrees Fahrenheit and confirm.

### Low temperature heating mode

The low temperature heating mode is a comfort function at higher outdoor temperatures.

The function modifies the control thresholds of the heater in order to harmonize heating mode, e.g. in the summer months.

-  Select and confirm.
- Select between ON and OFF and confirm.

### Resetting the user settings

-  Select and confirm.
- YES resets the user settings in the timer and deletes the programmed times, date and other settings.
- NO retains the existing user settings in the timer.



### Timer

The timer selection menu controls up to three programmable timer positions. The timer positions can either all take place on one weekday or can be distributed between different weekdays or weekday ranges.

Weekday ranges, e.g.

Monday – Friday: 5 x heat

Monday – Sunday : 7 x heat

If a programmed weekday range is activated, all the days of the week are processed in turn as long as the timer is active. Renewed programming is not necessary.

### **NOTE!**

- If the timer is activated with a programmed weekday range Monday – Friday on Sunday, the heater heats from the following Monday to Friday with the set defaults. (5x heating)
- If the timer is activated with a programmed weekday range Monday – Friday on Wednesday, the heater heats on Wednesday, Thursday and Friday. In the following week, operation is continued with the set defaults on Monday and Tuesday. (5x heating)
- When a weekday range has been processed, the time position has to be reactivated for the following week.

The heater starts on the selected day on reaching the set starting time.

## 154 Other controls Operator comfort

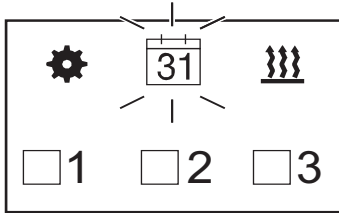

V1207486

Display if no timer is activated.

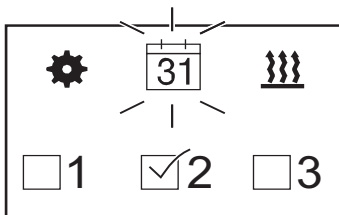

V1207487

Display if a timer is activated, here T2.

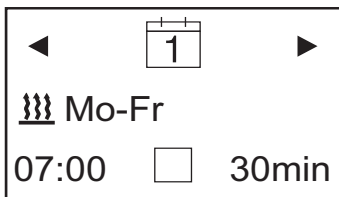

V1207488

T1 with factory settings

### Programming the timer

- Display ON, the Start mask appears.
- Select in the menu bar with the operating button.
- Confirm timer selection by pressing the operating button.  
The first timer position T1 appears. Turn the operating button to select the alternative timer positions T2 or T3.
- The factory settings are:
  - Heating mode
  - Weekday range Monday – Friday
  - Starting time: 7:00 h
  - Operating time: 30 minutes
- Call up timer T1 by pressing the operating button.  
You are now in configuration mode.

### NOTE!

The heater is connected to the battery, the operating time of the heater should not exceed the following working time of the machine. This will ensure that the battery is sufficiently charged.

Example:

Operating time of the heater: 25 minutes

Working time of the machine: minimum 25 minutes

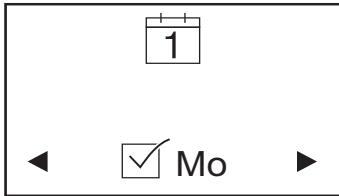

V1207489

Operating day

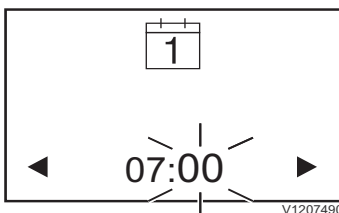

V1207490

Starting time

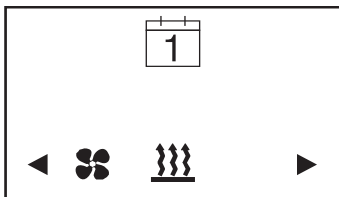

V1207491

Operating mode



V1207492

Operating time



V1207493

T1 settings

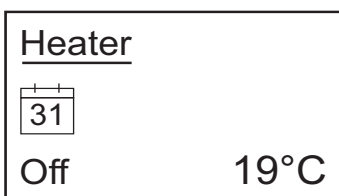

V1207539

Timer activated

### Possible settings

- Timer T1 ON / OFF by turning and pressing the operating button.
- After selecting ⚙️ in the menu bar, select the day of the week / weekday range by turning the operating button.  
Each day of the week is selected individually and confirmed by pressing. Pressing a second time deselects the day of the week again.  
At the end of the selection, turn the operating button to [OK] and press to confirm.
- Setting the starting time.  
Turning and pressing confirms first the hour, then the minutes.

- Selection of heating or ventilation mode.

- Select the operating time.  
minimum 10 minutes – maximum 120 minutes

- After activation of timer T1, the following appears on the display:
  - Heating mode
  - Weekday range Monday – Friday
  - Starting time: 6:30 h
  - Operating time: 25 minutes
- Timer T1 is activated. The heater will be started at the set time on the next working day and will run for 25 minutes.
- If a timer is activated, the timer symbol appears on the display.



Timer positions T2 and T3 can be configured in the same way.

**NOTE!**

To edit an existing timer, first select the timer and then press the operating button to switch to configuration mode. Then carry out the steps as described above.

**Deactivate timer**

To deactivate a timer position, first select the timer with the operating button. Press once and with OFF flashing, press the operating button again. All operating settings of the timer remain saved.

**NOTE!**

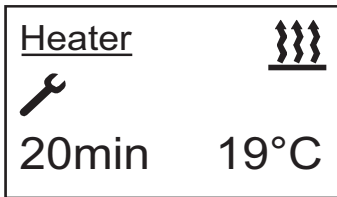

When a weekday range has been processed, the time position has to be reactivated for the following week.



### Fault diagnosis

If a fault occurs, the symbol  appears on the display during operation.





The LED ring flashes red as soon as a fault occurs. It stops flashing when the error message has been cancelled by pressing the operating button.

Fault diagnosis can also be called up with the function  in menu .

- Select  and confirm.
- Select and confirm the heater or timer.
- The faults are displayed in the order of their occurrence.







Further information see table below.

### Possible error messages on the display

Display	Description	Remedy
 Service <small>V1205824</small>	Fault in the heater.	Contact a qualified service technician.
 Undervoltage <small>V1205825</small>	Undervoltage applied at the heater control box without interruption for at least 20 seconds.	Check battery for a drop in voltage. Charge the battery, if necessary contact a qualified service technician.
 Overvoltage <small>V1205826</small>	Overvoltage applied at the heater control box without interruption for at least 20 seconds.	Check battery, if necessary contact a qualified service technician.
 Fuel Supply or Pump <small>V1205827</small>	Fault in the fuel supply or fuel pump.	Check the fuel line to the heater for free passage. Check cables for continuity, short circuit and damage. Pull the plug off the fuel pump and inspect for damage. Check the fuel level in the fuel tank. Contact a qualified service technician.



158 Other controls  
Operator comfort

Display	Description	Remedy
 Water Circuit or Pump <small>V1205828</small>	Water temperature in the heater too high.	Check the water pump for proper function. Check the water circulation in the water circuit. The heater can be reset to the delivery condition by removing the heater fuse. Contact a qualified service technician.
 Overheat. Heater locked. <small>V1207217</small>	Overheating of the heater detected. The heater is interlocked for safety reasons.	Check the heater and the water circuit for leaks. The heater can be reset to the delivery condition by removing the heater fuse. Contact a qualified service technician.
 Restricted Operation <small>V1207218</small>	Emergency running of the heater.	There is a fault in the heater. Restricted operation is still possible. Contact a qualified service technician.
 Ext. Temp. Sensor defective <small>V1207219</small>	The external temperature sensor is defective.	Contact a qualified service technician.
 Int. Temp. Sensor defective <small>V1207220</small>	The internal temperature sensor is defective.	Contact a qualified service technician.
 Rotary Knob jammed <small>V1207221</small>	The operating button is blocked.	Can the operating button be freed again by hand? Contact a qualified service technician.

Display	Description	Remedy
<div style="border: 1px solid black; padding: 5px; text-align: center;"> <p>◀ 4 ▶</p> <p>Pushbuton jammed</p> <p><small>V1207222</small></p> </div>	The button is blocked.	Can the button be freed again by hand? Contact a qualified service technician.
<div style="border: 1px solid black; padding: 5px; text-align: center;"> <p>◀ 7 ▶</p> <p>Timer mode not allowed</p> <p><small>V1207223</small></p> </div>	Timer mode is not permitted during ADR mode. (a)	Contact a qualified service technician.
<div style="border: 1px solid black; padding: 5px; text-align: center;"> <p>◀ 8 ▶</p> <p>Operation not supported</p> <p><small>V1207224</small></p> </div>	The heater is in auxiliary heating mode via Switching Plus and cannot be operated via Timer control unit during this time.	Contact a qualified service technician.
<div style="border: 1px solid black; padding: 5px; text-align: center;"> <p>◀ 9 ▶</p> <p>CAN communication error</p> <p><small>V1207225</small></p> </div>	Communication error on the CAN bus link.	Contact a qualified service technician.

a) ADR mode is reserved for vehicles transporting hazardous goods on the road. Not applicable for the machine.

**NOTE!**

If you are unable to remedy the error or fault, contact a qualified service technician.

**Winter season preparation for auxiliary heater**

Operator should exhaust remaining summer diesel in fuel line of auxiliary heater before winter season comes. Remaining summer diesel can cause plugging in fuel line if temperature drops in sudden because of wax crystallization. Run auxiliary heater at least 15 minutes until remaining diesel is exhausted.

When operator runs machine in winter season, it is recommended to fill fuel tank over 70%. If fuel tank has much empty space, it makes moisture inside of fuel tank. It can go to fuel line of auxiliary heater and frozen moisture sometimes makes fuel feeding problem.

### Fuel quality requirements for auxiliary heater

If the heater is run from a separate fuel tank, comply with the following rules.

- If ambient temperatures over 0 °C;  
Use diesel fuel according to DIN EN 590.
- If ambient temperatures from 0 °C to -20 °C;  
Use winter diesel fuel according to DIN 590.
- If ambient temperatures from -20 °C to -40 °C;  
Use Arctic diesel or Polar diesel.

#### NOTE!

- Used oil is not allowed.
- After refuelling with winter or cold diesel or the listed blends, the fuel pipes and the metering pump must be filled with the new fuel by letting the heater run for 15 minutes.
- Volvo does not recommend mixing Kerosene with diesel due to unstable combustion which causes decrease of durability of auxiliary heater and makes bad exhaust gas.
- Volvo recommends to use commercial additives which improve wax crystallization of diesel fuel in cold weather if it is difficult to use Arctic diesel or Polar diesel.

### Operation with bio-diesel fuel

The heater is approved for operation with bio-diesel up to a temperature of -8 °C (the flowability reduces at temperatures below 0 °C).

In case of storage periods longer than 30 days it is advisable to use FAME-free products, as ageing effects can have a negative effect on the fuel, especially regarding its flow properties and filterability.

#### NOTE!

Blending with max.30% FAME according to EN14214 is permitted.



---

## Operating instructions

This chapter contains rules which must be followed in order to operate the machine safely. However, these rules are to be followed in conjunction with laws or other national regulations applicable to road safety and labour welfare.

Alertness, judgement and respect for applicable safety regulations are conditions for avoiding risk of accidents.

### Running-in instructions

During the first 100 hours, the machine should be operated with a certain care. It is important to check oil and fluid levels often during the running-in period.

## Visibility

### **WARNING**

Risk of serious accidents.

Machine parts, equipment or load could obstruct the operator's view. Operating or driving with obstructed operator's view could cause serious accidents.

**Use a signal man if operator's view is obstructed.**

It may not be possible to provide direct visibility to all areas around the machine. To achieve acceptable visibility, additional devices such as warning systems, mirrors, and closed-circuit television cameras (CCTV) may be used.

In order to minimize hazards that may be caused by restricted visibility, rules or procedures shall be established by the job site management. For example:

#### **NOTE!**

Some parts of the basic machine may restrict visibility, for example, the cab's pillars, frames, exhaust pipe, engine hood, as well as optional equipment such as buckets, pallet forks, grapples, and so on. The load that is handled with these attachments may also restrict visibility.

- Ensure that operators and job site workers have received thorough safety instructions.
- Control the traffic patterns for the machine and other vehicles. Avoid travelling in reverse if possible.
- Restrict the machine's operating area.
- Use a signalman to help the operator. Use signals according to the signal diagram, see page 258.
- Provide two-way communication equipment if necessary.
- Ensure that job site workers communicate with the operator before approaching the machine.
- Use warning signs.



---

Standard ISO 5006 "Earthmoving machinery- Operator's field of view" deals with the operator's visibility around the machine and is meant to be used for measuring and evaluating the visibility.

The machine is tested by methods and performance criteria according to this standard. The visibility method used may not include all aspects of the operator's visibility, but provides information for determining if additional devices for indirect visibility, such as warning systems, are necessary.

The test was performed on machines with standard equipment and attachment. If the machine is modified or fitted with other equipment or attachment, which results in impaired visibility, it should be re-tested according to ISO 5006.

If other equipment or attachments are used and the visibility has been impaired, the operator should be informed.

Conforming to the standard is a requirement in EU-countries and provides for improved visibility around the machine.

Operating instructions

164

Mirror and camera (if installed) settings

Mirrors, adjusting

ISO 5006 states that an imaginary boundary line around the machine must be visible to the operator.

- Park the machine straight and on level ground.
- Adjust the mirrors until the imaginary boundary line is visible to the operator, see figure below.

**NOTE!**

Cameras may be also used to create visibility on the rectangular boundary. (Cameras are not adjustable on the machine.)

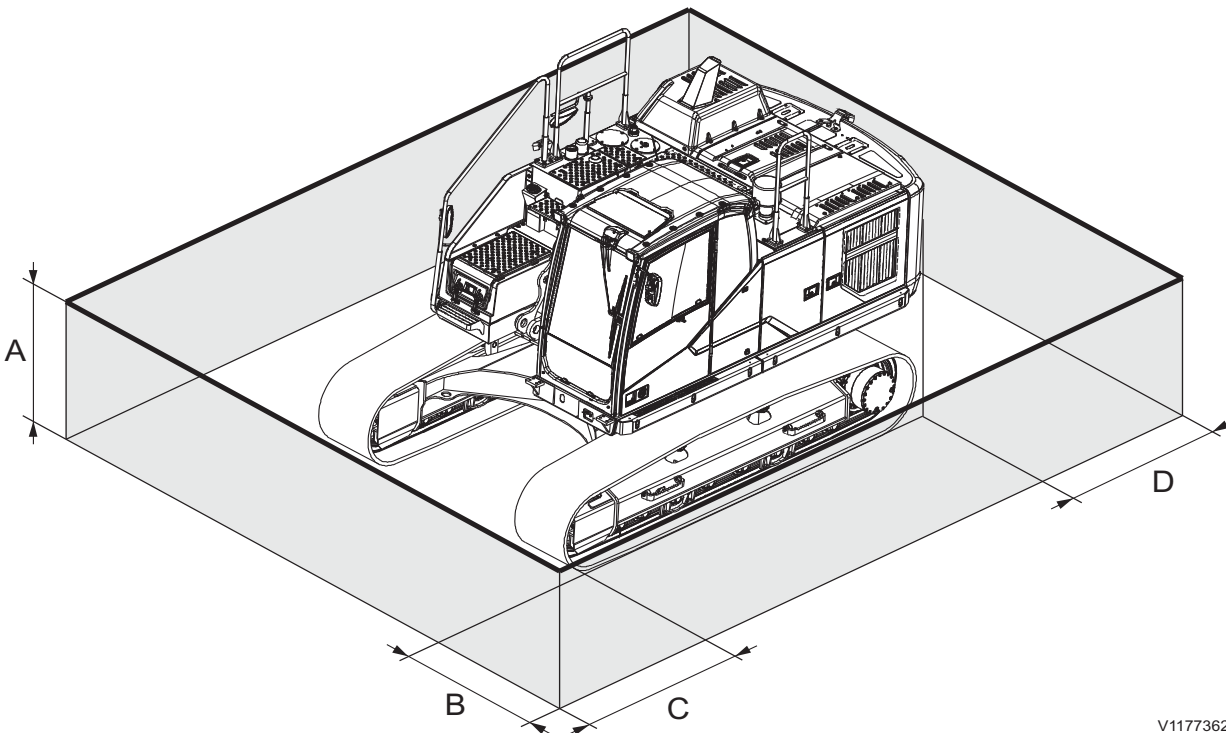

Close-up visibility boundary according to ISO 5006 (thick line)

- A 1.2 m (47.2 in)
- B 1.0 m (39.4 in)
- C 1.0 m (39.4 in)
- D 1.0 m (39.4 in)

V1177362

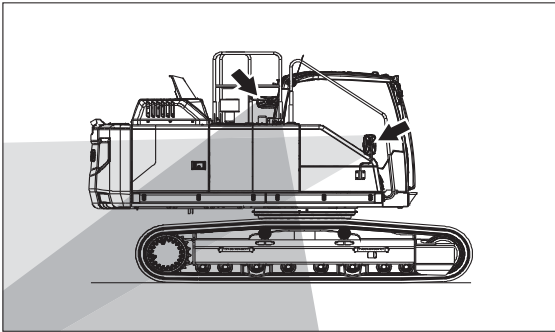

V1177363

Machine's right view

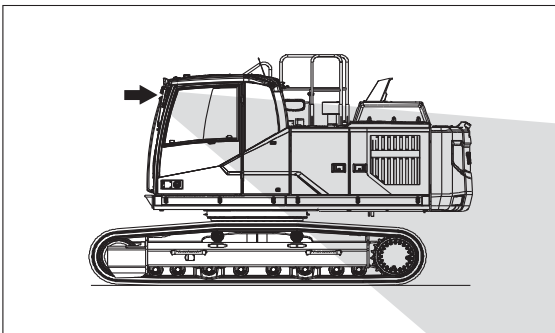

V1177364

Machine's left view

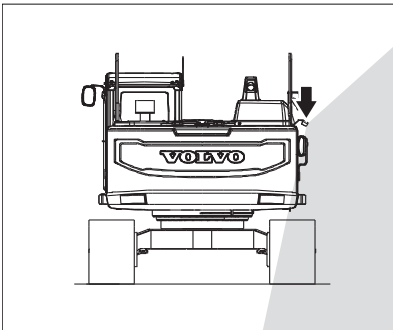

V1177366

Machine's rear view

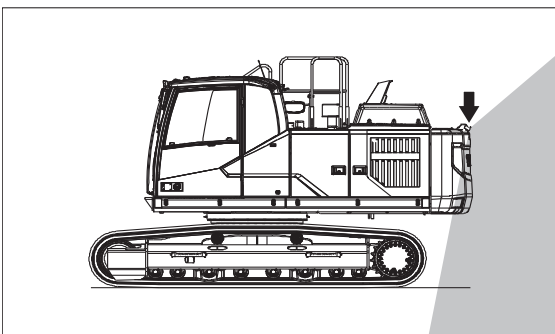

V1177367

Machine's left view

### Rear-view mirrors

Using the rear-view mirrors, check that you have as good visibility as possible towards the machine's superstructure and lower frame, and with as wide angle as possible. If not, adjust the rear-view mirrors until good visibility is obtained, see figures.

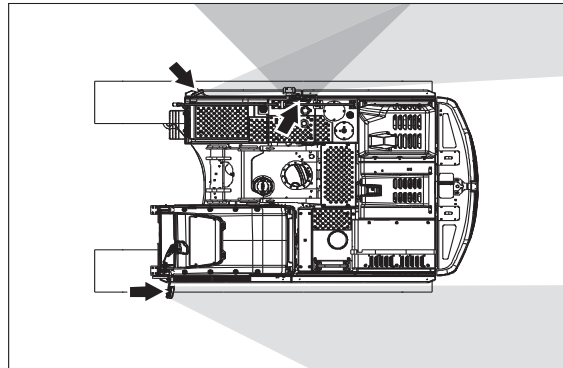

V1177365

Machine's top view

### Rear-view and Side-view cameras (if installed)

Check the rear-view and side-view camera's display screens, which are focused on the visible areas, for good visibility.

#### NOTE!

Cameras are not adjustable on the machine.

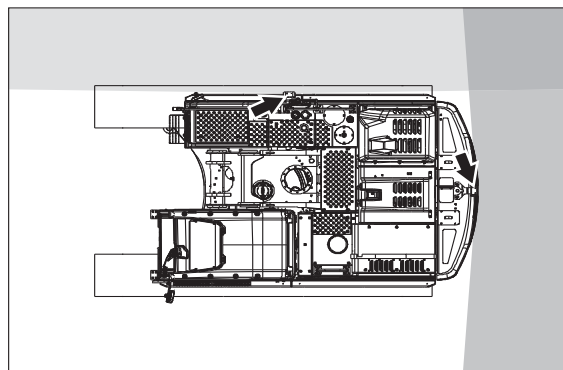

V1177368

Machine's top view





### Measures before and during operation

- Walk around the machine and check that there are no obstacles next to the machine.
- Check that mirrors and other visibility-enhancing devices are in good condition, clean, and correctly adjusted.
- Clean the cameras, if cameras are installed.

#### NOTE!

When you have direct access to the cameras for cleaning, be sure to use an appropriate external ladder or an appropriate platform.

- Check that the horn, back-up/travel alarm and rotating beacon (optional equipment) are working correctly.
- Check if the management has established rules or procedures for the work site.
- Always pay attention around the machine to identify any obstacles.
- Prevent persons from entering or remaining in the work area, i.e., the area around the machine and at least 7 m (23 ft) beyond the maximum reach of the attachment. However, depending on the job site's organization, the operator may allow a person to remain in the work area, but must then observe caution and operate the machine only when the person can be seen or has given clear indications of where he or she is.  
Never allow any person to walk or stand under raised equipment or suspended loads.

## Safety rules when operating

### Operator obligations

#### **WARNING**

Risk of fatal accidents.

Unauthorised persons within the work area around the machine could lead to serious crushing injury.

- **Clear all unauthorised personnel from the working area.**
- **Keep a lookout in all directions.**
- **Do not touch control levers or switches during start.**
- **Sound the horn before beginning operation.**
- The operator must operate the machine in such a way that the risk of accidents is minimized for both the operator and persons present on the work site.
- The operator must be thoroughly familiar with how to operate and maintain the machine and should undergo adequate training on the machine.
- The operator must follow the rules and recommendations in the Operator's Manual, but must also pay attention to any legislation and national regulations or specific requirements or risks that apply at the work site.
- The operator must be thoroughly rested and must never operate the machine when under the influence of alcohol, medicine, or other drugs.
- The operator is responsible for any load while working with the machine.
  - There must be no risk of the load falling off while operating.
  - Refuse to take a load which is an obvious safety risk.
  - Respect the stated maximum load for the machine. Pay attention to the effect of different distances to the centre of gravity and the effects of different attachments.

## 168 Operating instructions Safety rules when operating

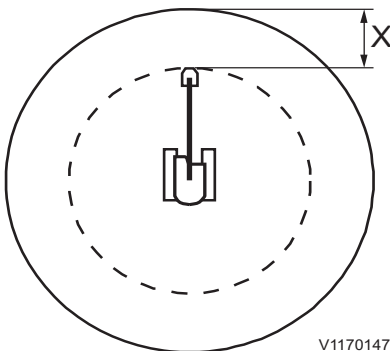

- The operator must check that the mirrors and cameras (if installed) are in good condition, clean, and adjusted correctly for good visibility before operating the machine.

### NOTE!

Cameras (if installed) are not adjustable on the machine. Check that the camera screen is displayed correctly on the IC (Instrument Cluster) when pressing the camera button on the keypad.

- The operator must be in control of the machine's work area.
  - Prevent persons from walking or standing under raised excavating equipment or suspended loads, unless it has been made safe or supported.
  - Prevent persons from entering or remaining in the work area, i.e., the area around the machine and at least 7 m (23 ft) beyond the maximum reach of the attachment. However, depending on the job site's organization, the operator may allow a person to remain in the work area, but must then observe caution and operate the machine only when the person can be seen or has given clear indications of where he or she is.
  - Prevent persons from being in the cab of a vehicle that is in a location with a risk that the cab may be hit by other machines or falling objects, for example, stones or logs. This does not apply if the cab is sufficiently strong or is protected to withstand the impact of such external forces.
  - Make sure that you know the weight limitation of the ground on which the machine is working.

The operator may only take an instructor on board, if there is an approved instructor's seat in the machine.

### **WARNING**

Risk of fatal accidents.

Using attachments for lifting or transporting persons may lead to fatal accidents with serious crushing injury or death.

**Never use attachments for lifting or transporting persons.**



## Accidents

- Accidents and also incidents should be reported to the site management immediately.
- If possible leave the machine in position.
- Only take necessary action so as to reduce the effect of damage, especially personal injuries. Avoid action which may make an investigation more difficult.
- Wait for further instructions from the site management.

## Operator safety

- The machine must be operational, that is faults which can cause accidents must be rectified.
- Suitable clothing for safe handling and a hard hat should be worn.
- Mobile phone should not be used when operating the machine. Follow all national regulations for mobile phone use during operation!
- Always sit in the operator seat when starting the engine/machine.
- Keep your hands away from areas where there is a risk of crushing, for example covers, door and window.
- Always use the seat belt.
- Check that the seat belt is not damaged or worn.
- Use steps and handholds when entering or leaving the machine. Use the three-point grip, that is two hands and one foot or two feet and one hand. Always face the machine - do not jump!
- The door must be closed.
- Check that the attachment is properly attached and locked.
- The vibration (shaking) which arises when operating may be harmful to the operator. Reduce this by:
  - adjusting the seat and tightening the seat belt.
  - picking the smoothest operating surface for the machine (levelling the surface when necessary).
  - adapting your speed.
- In case of travelling on uneven ground, do not let the machine lean more than 10° to one side.
- The cab has two emergency exits, the door and the rear window.
- Only walk and step on surfaces which are provided with anti-slip protection.



- During electrical storms, do not attempt to enter or exit the machine.
  - If you are off the machine, stay well away from the machine until the storm passes.
  - If you are in the cab, remain seated with the machine stationary until the storm passes. Do not touch controls or anything metal.
- In all kinds of works (travelling, digging, loading, hammering, and so on), place the idler side in front to reduce the travel drive damage due to incorrect operating position.
- When DPF regeneration;
  - Make sure that there is no flammable material around the machine, this is important to prevent risk of fire.
  - Move the machine to safety area, if there is a risk that people may get too close and then perform the regeneration.

 **WARNING**

**Risk for fire.**

**Regeneration generates hot exhaust and causes hot exhaust pipe. Do not perform regeneration in a flammable environment.**



### Operating on public roads

- Road signs, traffic restricting arrangements and other safety devices, which may be required when considering traffic speed and intensity or other local conditions, must be used.
- When moving the machine with a suspended load, special attention must be observed. when required, request the help of a signal man.
- Warning beacon may be used:
  - On attached or connected implement, which is wider than the vehicle itself.
  - When the vehicle constitutes a hindrance or danger to other traffic.
  - When working on or by the side of the roadway.



## Measures before operating

### **NOTICE**

The safety regulations and operating instructions issued by the manufacturer must be strictly observed.

- Read the Operator's manual.
- Carry out daily service, see page 283. In cold weather, make sure that the freezing point of the coolant is sufficiently low and that the lubricating oil is intended for winter use.
- Clean / scrape ice off the windows.
- Clean the dust around engine, battery and cooler.
- Check the level of hydraulic fluid, refill if required.
- Check that there is sufficient fuel in the fuel tank.
- Check that there are no faulty, loose parts or leaks, which can cause damage.
- Check that the battery disconnected switch is switched on.
- Check for cracks on frame and tracks.
- Check that hoods and covers are closed.
- Make sure fire extinguisher if equipped is fully charged.
- Inspect steps and handholds for damage or loose parts. Make necessary repairs if needed.
- Check that there are no persons in the vicinity of the machine.
- Adjust the operator seat and fasten the seat belt.
- Adjust and clean the mirrors.
- Inspect working and other lights for proper operation.
- Travel alarm should be on before operating the machine.
- Inspect the failure of gauges in the instrument panels.
- Check the function of the attachment quick coupler (optional equipment).

## Starting engine

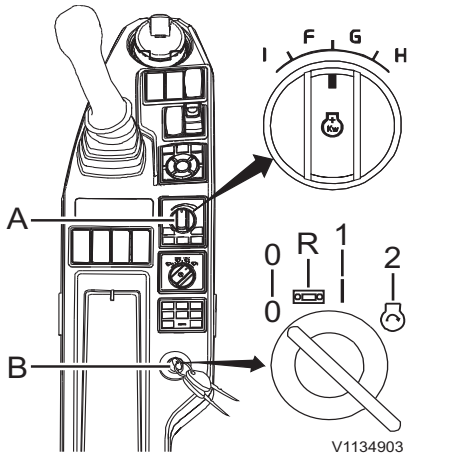

- A Engine speed control switch  
B Ignition switch

- Off position (0)  
Radio position (R)  
Operating (preheating) position (1)  
Start position (2)

### NOTE!

Make sure the control lockout lever is in downward (lockout) position, otherwise the engine can not be started.

### WARNING

Risk of fatal accidents.

Unauthorised persons within the work area around the machine could lead to serious crushing injury.

- Clear all unauthorised personnel from the working area.
- Keep a lookout in all directions.
- Do not touch control levers or switches during start.
- Sound the horn before beginning operation.

### NOTICE

Do not keep the ignition switch in starting position for more than 20 seconds, as this may seriously damage the starting system. If the engine does not start, turn the switch back to stop position and wait a couple of minutes before the next starting attempt.

### NOTICE

If the engine sounds or runs strangely or if strong vibrations arise, the ignition switch must be turned to stop position immediately.

### NOTICE

Wait until the electronic system is completely shut down before restarting.

- 1 Turn the engine speed control switch (A) to the low speed position and turn the key to operating position.
- 2 Sound the horn and let other workers and bystanders know you are starting the machine. For the startup sequence, see page 43.
- 3 Turn the key to the start position.
- 4 Release the key when the engine has started.
- 5 Warm up the machine.



174 Operating instructions  
Starting engine



V1065729

Preheating indicator

## Starting engine in cold weather

- 1 Turn engine speed control switch (A) to the low speed position.
- 2 Turn the key to the running (preheating) position and keep it there while the preheating is working. The preheating indicator will be displayed on the indicator screen of IC (Instrument cluster).
- 3 When the preheating is finished, sound the horn and let other workers and bystanders know you are starting the machine.
- 4 Turn the key to the starting position.
- 5 Release the key when the engine has started.
- 6 Warm up the machine. Run at low speed and with a light load until the oil in the engine and hydraulic system has warmed up.

### NOTICE

Run the engine at low idling speed for 10–15 minutes to warm the engine and the hydraulic system at temperatures below  $-15^{\circ}\text{C}$  ( $+5^{\circ}\text{F}$ ) before putting the machine to work.

Use recommended lubricating oil for winter use. See page 343.

During the cold season, fill the fuel tank after work has finished for the day to counteract the formation of condensation water in the tank.

## Engine block heater

(optional equipment)

This equipment is used to reduce the engine load which cause the wear in the engine when starting the machine in cold weather region.

### NOTICE

The machine may be equipped with cylinder block heater for either 120 V or 240 V. Compare the specified voltage of the external power supply and with that of the cylinder block heater.

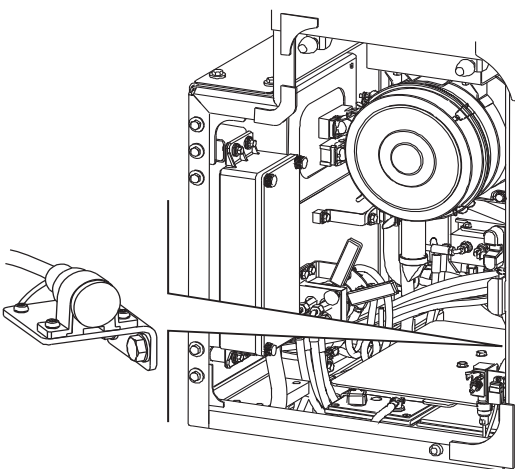

V1147334

Socket for block heater



## Starting with booster batteries

### **WARNING**

Risk of explosion.

Batteries could explode due to the current surge if a fully charged battery is connected to a completely discharged or frozen battery.

**Do not boost start a machine with a completely discharged or frozen battery.**

When starting with booster batteries, check that the booster batteries or other power source have the same voltage as the batteries of the machine. If the batteries in another machine are used the engine of that machine must be turned off.

### **NOTICE**

**Do not attempt to start the engine while the battery charger is still connected to the mains. This may cause serious damage to the electronic control units.**

- 1 Turn OFF the battery disconnect switch.
- 2 Remove the protections from the battery pole studs.

**Connect two 12 V batteries as follows :**

- 3 Connect one of the jump leads between (+) terminal on the battery of the machine and the (+) terminal on the booster battery.
- 4 Connect the other jump lead between the (-) terminal of the booster battery and a grounding point on the machine.

### **NOTICE**

**Do not connect ground to the undercarriage on the machine. This may seriously damage the swing bearing.**



## 176 Operating instructions Starting engine

---

- 5 Connect the batteries of the machine by turning on the battery disconnect switch.
- 6 Start the engine with the ignition switch in a cab.
- 7 Leave the batteries connected for 5-10 minutes after starting the engine.
- 8 Disconnect the jump lead from the chassis connection on the machine, and then disconnect the other end of the jump lead from the (-) terminal on the booster battery.
- 9 Finally disconnect the jump lead between the (+) terminals.
- 10 Re-install the battery pole stud protections.

### Warming up

Machine may respond slowly at low temperatures. Operate carefully until the system has reached normal temperature. Otherwise unexpected movements may occur.

## Hydraulic system, warming up

The oil in machine's hydraulic system is used for operating the hydraulic cylinders of the equipment as well as the hydraulic motors for travelling and swinging. When the oil is cold it is viscous.

Therefore the machine's hydraulic functions operate slower than when the oil is warm.

Malfunctions may result if one or more of the machine functions are forced against end-position without first having warmed up the system.

### NOTE!

Operate the machine functions (travel, swing, and attachments) very slowly and carefully.

### WARNING

Risk of crushing injury.

The hydraulic system could respond slowly at low temperatures and could cause unexpected machine movements.

**Operate carefully until the hydraulic system has reached operating temperature.**

### NOTICE

**Do not rush warming of the oil, since forced warming can damage the machine.**

### WARNING

Risk of crushing.

Sudden movement of attachments may cause serious injury or death to personnel near the machine.

Quick-acting controls operate the optional attachments. Operate the controls carefully.

## 178 Operating instructions Hydraulic system, warming up

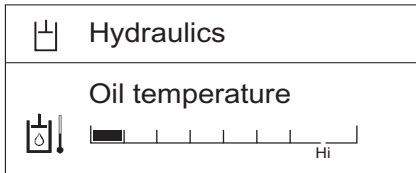

V1140828

Hydraulic oil temperature screen

- 1 Start the engine and let it run at low idle for 5 minutes.
- 2 Then increase engine speed to approx. 1,200 rpm.
- 3 Carefully follow the instructions given below.
  - If the green bar for hydraulic oil temperature covers more than one gradation, perform the next steps 4 and 5.
  - If the green bar for hydraulic oil temperature covers less than one gradation, raise the boom slightly from the ground and operate bucket-in and bucket-out using the control lever for 5 minutes (stop operation for 2-3 seconds after 1 operation, i.e. bucket-in or out). After 5 minutes, if the green bar for hydraulic oil temperature has not reached one gradation, operate bucket-in using the control lever and hold the control lever in that position for 10 seconds to reach relief pressure. Release the control lever for 5 seconds and then repeat the operation until the green bar has reached one gradation.
- 4 Run out the bucket cylinder using the control lever and let the bucket move to its end-position.
- 5 Then carry out a number of boom, dipper arm, swing, and travel movements with the machine to distribute the warmed hydraulic oil to all hydraulic cylinders and motors.

Carry out these movements until the hydraulic system has reached working temperature/rapid working movements.

### Travelling a short distance

Moving the machine a short distance (for example, when loading onto or off a trailer) may be done without a complete warm-up. This operation must be done with great care. Under these conditions the engine speed must not exceed 1,200 rpm and the travel speed control should be in low speed position.



---

## Operating

### **NOTICE**

In order not to jeopardise the lubrication of the engine, the machine must not be inclined more than 35 degrees in either direction. In addition it may be unsuitable to operate at this inclination as the machine may become unstable and unbalanced, depending on the load.

### **NOTE!**

Do not jack the track up more than 35 degrees using attachment. Otherwise counterweight can be damaged.

### **NOTE!**

If the machine is equipped with travel warning system, a warning alarm sounds when levers or pedals are actuated.

For more operating information, see page 94.

## Exhaust aftertreatment system

### Regeneration

#### **WARNING**

Risk of burns.

Engine and exhaust system components get very hot and can cause severe burns.

**Avoid contact with engine compartment covers, engine components and exhaust system until the engine is cooled down.**

#### **NOTE!**

Some smoke might be seen coming from the exhaust stack during regeneration of the aftertreatment system on a machine run on diesel fuel with high sulfur content.

The purpose of regeneration is to raise the temperature in the aftertreatment system so that any trapped substances are burned off to allow the system to regain its full capacity.

#### **Normal operation**

During normal operation, passive regeneration occurs continuously.

#### **Parked regeneration**

Parked regeneration may be necessary if

- previous regeneration steps have failed or have been cancelled repeatedly
- too much time has passed since the last regeneration
- the aftertreatment system has accumulated excessive amounts of particles or sulphur

No work can be performed during a parked regeneration. The engine speed is raised during a parked regeneration. It is not advisable to cancel a parked regeneration which is in progress, except in an emergency.

To start a parked regeneration, the operator must stop the machine, lower the control lockout lever to

	Regeneration
<input type="radio"/>	Stop
<input checked="" type="radio"/>	Start

V1147263

## Operating instructions Exhaust aftertreatment system 181

lock the system and select "Start" in the regeneration menu on the IC (Instrument Cluster).

### NOTE!

The operator can start the regeneration immediately by pressing the SELECT button on the IC (Instrument Cluster) control keypad when an alarm indication for regeneration pops up on the IC (Instrument Cluster).

During regeneration, the HEST (High exhaust temperature) lamp is on, see symbol. This is to indicate that regeneration is in progress and that the exhaust temperature has increased. Do not turn off the engine while the HEST lamp is on.

### NOTE!

The machine must be in an area that is not heat-sensitive while the symbol is lit.

### Service regeneration

If a requested regeneration is delayed for too long, the PM (particulate matter)-load in the DPF (diesel particulate filter) and the amount of sulphur in the SCR (selective catalytic reduction) will be too high for a safe parked regeneration. Then regeneration must be started with Volvo's service tool in order to perform a safe regeneration.

### Fuel consumption

During a parked regeneration, the fuel consumption may increase.

### Delaying regeneration

The operator can delay the regeneration by pressing the ESC button on the IC (Instrument Cluster) control keypad when an alarm indication for regeneration pops up on the IC (Instrument Cluster). The alarm indication will pop up again after 15 minutes or when the engine is restarted. Delayed regeneration may be useful if the machine is in a heat-sensitive environment.

### NOTE!

**It is important to not delay regeneration unnecessarily.**

### Possible consequences of delaying regeneration:

- engine derate.
- higher fuel consumption.
- shorter diesel particulate filter service life.
- damage to the aftertreatment system.

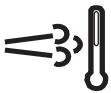

V1083542

HEST (High exhaust temperature) lamp, regeneration in progress



182 Operating instructions  
Exhaust aftertreatment system

**Cancelling parked regeneration**

**NOTE!**

Only cancel in an emergency.

- 1 Select "Stop" in the regeneration menu on the IC (Instrument Cluster).

An alarm indication on the instrument panel confirms that regeneration has been cancelled.

Regeneration is cancelled automatically when:

- a malfunction occurs
- machine operation starts and a parked regeneration is in progress
- the machine is turned off









V1135633





Regeneration cancelled

Alarms that require specific action			
Text on display panel	Display indication	Alarm level	Action
Park soon Parked regeneration needed	Warning, amber  V1128635	- buzzer sounds - amber central warning on	1 Park the machine in a non-heat-sensitive area. 2 Move the control lockout lever down to lock the system. 3 Start regeneration.  <b>NOTE!</b> Regeneration is cancelled if the control lockout lever is set to unlocked position or the engine is turned off. <b>NOTE!</b> The idle speed will be increased during the entire regeneration process.





Operating instructions  
Exhaust aftertreatment system 183

<p>Start regeneration Parked regeneration possible Press [SELECT] to start</p>	<p>Warning, amber</p>   <p>V1128635</p>	<ul style="list-style-type: none"> <li>- buzzer sounds</li> <li>- amber central warning on</li> </ul>	<ol style="list-style-type: none"> <li>1 Park the machine in a non-heat-sensitive area.</li> <li>2 Move the control lockout lever down to lock the system.</li> <li>3 Start regeneration.</li> </ol> <p><b>NOTE!</b> Regeneration is cancelled if the control lockout lever is set to unlocked position or the engine is turned off. <b>NOTE!</b> The idle speed will be increased during the entire regeneration process.</p>
<p>Keep machine parked Regeneration ongoing</p>	<p>Warning, amber</p>   <p>V1128635</p>	<ul style="list-style-type: none"> <li>- buzzer sounds</li> <li>- amber central warning on</li> </ul>	<ol style="list-style-type: none"> <li>1 Keep the machine parked.</li> </ol>
<p>Regeneration cancelled</p>	<p>Warning, amber</p>   <p>V1135633</p>	<ul style="list-style-type: none"> <li>- buzzer sounds</li> <li>- amber central warning on</li> </ul>	<ol style="list-style-type: none"> <li>1 Restart regeneration when possible.</li> </ol>







184 Operating instructions  
Exhaust aftertreatment system

<p>Park machine Parked regeneration required</p>	<p>Warning, amber</p>   <p>V1128635</p>	<ul style="list-style-type: none"> <li>- buzzer sounds</li> <li>- amber central warning on</li> </ul>	<ol style="list-style-type: none"> <li>1 Park the machine in a non-heat-sensitive area.</li> <li>2 Move the control lockout lever down to lock the system.</li> <li>3 Start regeneration.</li> </ol> <p><b>NOTE!</b> Regeneration is cancelled if the control lockout lever is set to unlocked position or the engine is turned off.</p> <p><b>NOTE!</b> The idle speed will be increased during the entire regeneration process.</p>
<p>Park safely Service regeneration needed</p>	<p>Warning, red</p>   <p>V1128638</p>	<ul style="list-style-type: none"> <li>- buzzer sounds</li> <li>- red central warning on</li> </ul>	<ol style="list-style-type: none"> <li>1 Park the machine in a non-heat-sensitive area.</li> <li>2 Move the control lockout lever down to lock the system.</li> <li>3 Turn off the engine.</li> <li>4 Contact a qualified service technician for regeneration.</li> </ol> <p><b>NOTE!</b> Regeneration is only possible using Volvo's service tool.</p>

Operating instructions  
Exhaust aftertreatment system 185

<p>Park machine Service needed Derate active</p>	<p>Warning, red</p>  <p>V1128638</p>	<ul style="list-style-type: none"> <li>- buzzer sounds</li> <li>- red central warning on</li> <li>- engine performance is significantly reduced</li> </ul>	<ol style="list-style-type: none"> <li>1 Park the machine in a non-heat-sensitive area.</li> <li>2 Move the control lockout lever down to lock the system.</li> <li>3 Turn off the engine.</li> <li>4 Contact a qualified service technician for replacement of the diesel particulate filter.</li> </ol> <p><b>NOTE!</b> The soot load can only be reset by qualified service technician.</p>
<p>Regeneration not needed</p>	<p>Information, blue</p>  <p>V1088268</p>	<ul style="list-style-type: none"> <li>- buzzer sounds</li> <li>- blue central warning on</li> </ul>	<ol style="list-style-type: none"> <li>1 No action required.</li> </ol>
<p>Continue operation Low temperature Regeneration pending</p>	<p>Warning, amber</p>  <p>V1128635</p>	<ul style="list-style-type: none"> <li>- buzzer sounds</li> <li>- amber central warning on</li> </ul>	<ol style="list-style-type: none"> <li>1 Continue operating the machine to warm up the exhaust aftertreatment system.</li> </ol>
<p>Service needed Regeneration not possible System failure</p>	<p>Warning, amber</p>  <p>V1203417</p>	<ul style="list-style-type: none"> <li>- buzzer sounds</li> <li>- amber central warning on</li> </ul>	<ol style="list-style-type: none"> <li>1 Service required.</li> <li>2 Contact a qualified service technician.</li> </ol>
<p>Lower CTRL lockout lever Regeneration needed</p>	<p>Warning, amber</p>  <p>V1128635</p>	<ul style="list-style-type: none"> <li>- buzzer sounds</li> <li>- amber central warning on</li> </ul>	<ol style="list-style-type: none"> <li>1 Park the machine in a non-heat-sensitive area.</li> <li>2 Move the control lockout lever down to lock the system.</li> <li>3 Start regeneration.</li> </ol>

Operating instructions  
**186 Exhaust aftertreatment system**

<p>Set engine speed as I2 Parked regeneration needed</p>	<p>Warning, amber</p>   <p>V1128635</p>	<ul style="list-style-type: none"> <li>- buzzer sounds</li> <li>- amber central warning on</li> </ul>	<ol style="list-style-type: none"> <li>1 Set the engine speed control switch as I2 mode.</li> <li>2 Park the machine in a non-heat-sensitive area.</li> <li>3 Move the control lockout lever down to lock the system.</li> <li>4 Start regeneration.</li> </ol>
<p>Park safely Only available when parked</p>	<p>Information, blue</p>   <p>V1088268</p>	<ul style="list-style-type: none"> <li>- buzzer sounds</li> <li>- blue central warning on</li> </ul>	<ol style="list-style-type: none"> <li>1 Park the machine in a non-heat-sensitive area.</li> <li>2 Move the control lockout lever down to lock the system.</li> <li>3 Start regeneration.</li> </ol>
<p>Arctic regen disabled</p>	<p>Information, blue</p>   <p>V1088268</p>	<ul style="list-style-type: none"> <li>- buzzer sounds</li> <li>- blue central warning on</li> </ul>	<ol style="list-style-type: none"> <li>1 Park the machine in a non-heat-sensitive area.</li> <li>2 Check that the arctic regeneration mode in IC (Instrument Cluster) menu is enabled.</li> </ol>



## Emission compliance

The aftertreatment system is monitored by diagnostic systems in the control units to ensure reduced emissions. If the system does not meet the emission requirements, it should not be possible to use the machine for work as usual. This takes place by a reduction of engine power (derate).

### Engine power is reduced if:

- The level in the AdBlue®/DEF tank is too low
- AdBlue®/DEF is of low quality
- There is a problem/malfunction with the aftertreatment system

There are two levels of engine power reduction (derate) that are activated after a certain time depending on the type of problem, as well as if the malfunction reoccurs or not.

### Restoring engine function

If the engine is restarted (by turning the ignition off and on) when engine power has been reduced, then full engine power (called restored engine function) can be obtained twice during derate level 1. This can be done in case of a danger or hazard and, e.g., if the machine has to be moved. This will not extend the time for activation of derate level 2.









188 Operating instructions  
Exhaust aftertreatment system

### Exhaust aftertreatment system, alarms requiring special actions

**NOTE!**

The display text will show "AdBlue®" in machines for the European market and "DEF" in machines for the US market.

AdBlue®/DEF level monitoring		
Display figure	Alarm level	Action
—	- solid symbol	1 Turn off the engine. 2 Fill AdBlue®/DEF in the AdBlue®/DEF tank.
Refill AdBlue  V1126376 AdBlue empty Derate active	- buzzer sounds 4 times - amber central warning on  V1205598 - flashing symbol - torque reduction	1 Turn off the engine. 2 Fill AdBlue®/DEF in the AdBlue®/DEF tank.
Park safely  V1126376 AdBlue empty Full derate soon	- buzzer sounds continuously - red central warning on  V1205599 - flashing symbol - torque reduction	1 Turn off the engine. 2 Fill AdBlue®/DEF in the AdBlue®/DEF tank.
Refill AdBlue  V1126376 AdBlue empty Full derate active	- buzzer sounds continuously - red central warning on  V1205599 - flashing symbol - forced idle or torque and speed reduction (depending on market)	1 Turn off the engine. 2 Fill AdBlue®/DEF in the AdBlue®/DEF tank.











Operating instructions  
Exhaust aftertreatment system

AdBlue®/DEF quality monitoring		
Display figure	Alarm level	Action
<p>Replace AdBlue</p> <p>Wrong AdBlue quality Derate soon</p>	<ul style="list-style-type: none"> <li>- buzzer sounds 4 times</li> <li>- amber central warning on</li> </ul> <ul style="list-style-type: none"> <li>- solid symbol</li> </ul>	<p>Contact a qualified service technician.</p>
<p>Replace AdBlue</p> <p>Wrong AdBlue quality Derate active</p>	<ul style="list-style-type: none"> <li>- buzzer sounds 4 times</li> <li>- amber central warning on</li> </ul> <ul style="list-style-type: none"> <li>- flashing symbol</li> <li>- torque reduction</li> </ul>	<p>Contact a qualified service technician.</p>
<p>Park safely</p> <p>Wrong AdBlue quality Full derate soon</p>	<ul style="list-style-type: none"> <li>- buzzer sounds continuously</li> <li>- red central warning on</li> </ul> <ul style="list-style-type: none"> <li>- flashing symbol</li> <li>- torque reduction</li> </ul>	<p>Contact a qualified service technician.</p>
<p>Replace AdBlue</p> <p>Wrong AdBlue quality Full derate active</p>	<ul style="list-style-type: none"> <li>- buzzer sounds continuously</li> <li>- red central warning on</li> </ul> <ul style="list-style-type: none"> <li>- flashing symbol</li> <li>- forced idle or torque and speed reduction (depending on market)</li> </ul>	<p>Contact a qualified service technician.</p>









190 Operating instructions  
Exhaust aftertreatment system

SCR-system failure monitoring		
Display figure	Alarm level	Action
Check SCR-system  V1201756 SCR-system failure Derate soon	<ul style="list-style-type: none"> <li>- buzzer sounds 4 times</li> <li>- amber central warning on</li> </ul>  V1205598 <ul style="list-style-type: none"> <li>- solid symbol</li> </ul>	Contact a qualified service technician.
Check SCR-system  V1201756 SCR-system failure Derate active	<ul style="list-style-type: none"> <li>- buzzer sounds 4 times</li> <li>- amber central warning on</li> </ul>  V1205598 <ul style="list-style-type: none"> <li>- flashing symbol</li> <li>- torque reduction</li> </ul>	Contact a qualified service technician.
Park safely  V1201756 SCR-system failure Full derate soon	<ul style="list-style-type: none"> <li>- buzzer sounds continuously</li> <li>- red central warning on</li> </ul>  V1205599 <ul style="list-style-type: none"> <li>- flashing symbol</li> <li>- torque reduction</li> </ul>	Contact a qualified service technician.
Check SCR-system  V1201756 SCR-system failure Full derate active	<ul style="list-style-type: none"> <li>- buzzer sounds continuously</li> <li>- red central warning on</li> </ul>  V1205599 <ul style="list-style-type: none"> <li>- flashing symbol</li> <li>- forced idle or torque and speed reduction (depending on market)</li> </ul>	Contact a qualified service technician.
DPF-system failure monitoring		
Display figure	Alarm level	Action
Check DPF-system  V1201756 DPF-system deactivated	<ul style="list-style-type: none"> <li>- buzzer sounds 4 times</li> <li>- amber central warning on</li> </ul>  V1205598 <ul style="list-style-type: none"> <li>- solid symbol</li> </ul>	Contact a qualified service technician.



Operating instructions  
Exhaust aftertreatment system 191

<p>Check DPF-system</p>  <p>V1201756</p> <p>DPF-system missing</p>	<ul style="list-style-type: none"> <li>- buzzer sounds 4 times</li> <li>- amber central warning on</li> </ul>  <p>V1205598</p> <ul style="list-style-type: none"> <li>- solid symbol</li> </ul>	<p>Contact a qualified service technician.</p>
<p>Check DPF-system</p>  <p>V1201756</p> <p>DPF-system failure</p>	<ul style="list-style-type: none"> <li>- buzzer sounds 4 times</li> <li>- amber central warning on</li> </ul>  <p>V1205598</p> <ul style="list-style-type: none"> <li>- solid symbol</li> </ul>	<p>Contact a qualified service technician.</p>



## Stopping

- 1 Select as level ground as possible to park the machine.
- 2 Lower the attachment to the ground.
- 3 Leave the engine running at low idling speed for approx. 2 minutes before shutting off the engine. Otherwise the lubrication of the turbocharger may be jeopardised, resulting in shorter service life and great risk of bearing seizure.
- 4 Turn the ignition switch to stop position.
- 5 Move the control lockout lever down to lock the hydraulic system securely.
- 6 If the machine is to be left for any length of time, the battery disconnect switch should be turned off.

Keep in mind that the theft and burglary risk can be minimised by:

- Removing the ignition switch when the machine is left unattended.
- Locking doors and covers after working hours.
- Turning off the current with the battery disconnect switch.
- Parking the machine where the risk of theft, burglary and damage is minimised.
- Removing all valuables from the cab such as cellular phone, computer, radio and bags.
- Chaining the machine.

By etching in the PIN-number or the national licence plate number of the machine on its windows, it is easier to identify stolen machines.

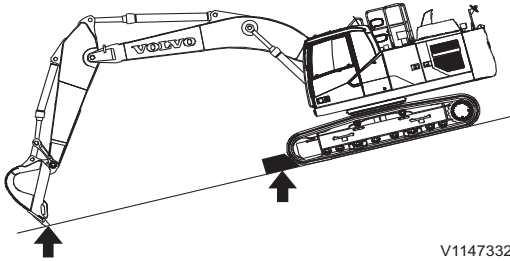

V1147332

## Parking

### NOTICE

Choose level ground for parking the machine. If the machine has to be parked on an incline, the tracks must be blocked with wooden blocks and the bucket teeth pressed into the ground.

- 1 Park the machine with proper condition that the piston rods of the attachments will be protected against moisture, dust and damage.
- 2 Follow the paragraphs 3 - 6 above of "Stopping".
- 3 Make sure that there is enough anti-freeze in the cooling system (see page 312) and in the washer fluid at temperatures below 0 °C (32 °F) when the machine is parked.
- 4 Make sure that the AdBlue®/DEF tank is completely filled.
- 5 The temperature may not be below -40 °C (-40 °F) or above +40 °C (104 °F) if the machine will be parked for up to two months.
- 6 Close and lock all windows, doors and all covers.

### Long-term parking (parking for longer time than two months)

Follow the instructions as for parking and in addition to that:

- 1 The temperature may not be below -40 °C (-40 °F) or above +25 °C (77 °F).
- 2 Wash the machine and touch up the paint finish to avoid rusting.
- 3 Check the machine for leakage of oil or water, and defects of the attachments and the tracks. Replace or repair all damaged or worn parts.
- 4 Treat exposed parts with anti-rust agent, lubricate the machine thoroughly and apply grease to unpainted surfaces like cylinders.
- 5 Fill the fuel tank and the hydraulic oil tank to the maximum marks.
- 6 Make sure that the freezing point of the coolant is sufficiently low (in cold weather).
- 7 Place the machine on level, firm ground where there is no risk of freezing, landslide or flooding.
- 8 When storing machines in extreme cold temperatures, remove batteries and store them at room temperature. Make sure to place the batteries over a wooden/plastic/rubber surface.



- 9 Cover the exhaust pipe (for parking out-of-doors).

**NOTICE**

Start the engine once a month and run it at low idling speed for one hour. Operate all function cycles when working temperature has been reached.

**Check after long-term parking**

- All oil and fluid levels
- Tension of all belts
- Air cleaner
- Batteries
- Lubricate all greasing points
- Wipe off grease from piston rods
- Hydraulic hoses
- Seals
- That the AdBlue®/DEF pump unit filter is replaced if the machine is parked for longer than four months. Contact a qualified service technician.

**NOTE!**

If a preservative has been used on the machine to prepare it for long term storage, follow the manufacturer's instructions for any necessary safety precautions and the method of removal.

## Retrieving and towing

### WARNING

Risk of personal injury.

Faulty or improper lifting equipment could cause the machine to break away from the lifting vehicle, causing accidents, serious injury or death.

**Use certified cables, lifting straps, slings, shackles and hooks with adequate load capacity and never lift the machine with a person in or on the machine.**

### WARNING

Risk of runaway machine.

Improper towing methods or faulty equipment could cause the machine to break away from the towing vehicle, causing accidents, serious injury or death.

**Carefully follow the towing instructions and use only certified towing equipment with adequate load rating.**

### NOTE!

Only use the rear-mounted towing hook and the attaching point for a towing bar for towing the machine.

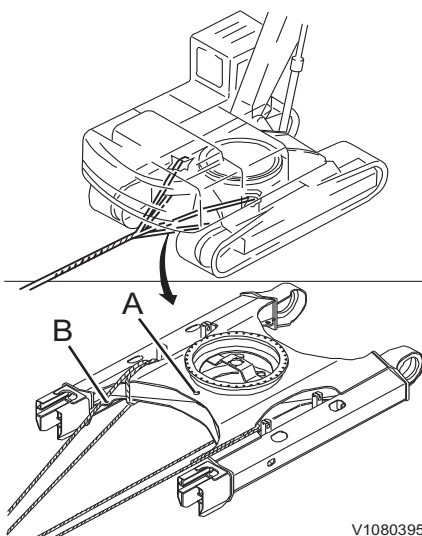

V1080395

Retrieval device is used when the machine is in the event of slipping into swampy ground or being disabled.

- 1 Attach a wire rope to be retrieved or to tow the machine as shown in the illustration. Ensure that the towing linkage is properly connected, adequate for the purposes.
- 2 Towing speed for short distance is maximum 2 km/h and use other transportations for long distance.
- 3 Keep the tow line angle as small as possible
- 4 Angle for pulling should not exceed 20° from the horizontal line of tow lope and longitudinal axis of the machine. Be careful there should not be also interference with parts of the machine.

There is a hole (A) on the lower frame to fit the shackle only for towing light objects.

- 1 The shackle must be used for the hole (A).
- 2 Permissible forces of the hole (A) for towing is as follows.

196 Operating instructions  
Retrieving and towing

■ 13,900 kg (30,643 lb)

**NOTE!**

Do not use shackle holes (B) to retrieve or tow the machine. These holes are only for anchoring when transporting the machine, see page 200.

**Manual release of travel brake**

If it is impossible to operate the machine due to the failure of the components in the track motor, the travel brake should be released. Contact a qualified service technician for detailed information.

- 1 Apply constant hydraulic pressure of 3.9 MPa (40 kgf cm<sup>2</sup>, 569 psi) at port (A) of the track motor using external pressure source to keep the brake released.
- 2 Connect a hydraulic hose between port (B) and port (C) after removing plugs to move the machine.

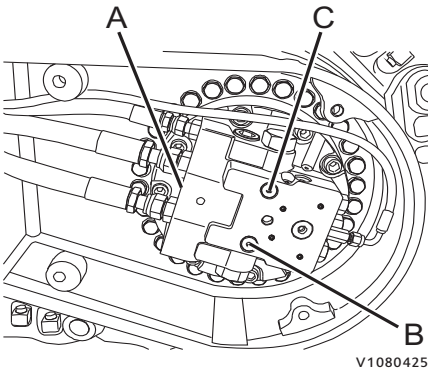

V1080425

- A Brake released port
- B Pressure gauge port
- C Pressure gauge port



## Transporting machine

### Measurements before transporting machine

#### **NOTICE**

The person in charge of the transport must see to that loading, positioning, lashing and transporting the machine on a trailer or other vehicle is done according to applicable laws and regulations for the country or state in question. For further information, contact your dealer.

#### **NOTICE**

If vandal protection is installed on the machine, it should be removed before the machine is transported. Check local or national regulations.

### Total and disassembled specifications, weight and dimension

Weight and dimension are very useful to estimate the method how the disassembled parts are supposed to be transported. To comply with the laws and regulations in certain region, use the specifications of total and disassembled parts. See pages 418, 369 and 428.



## 198 Operating instructions Transporting machine

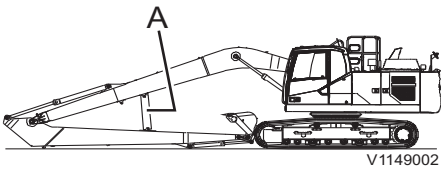

### Transporting the machine with long attachments

Although dipper arm is folded, cylinders are given excessive forces caused by self-gravity of attachments. Insert a stay (A) between dipper arm and boom for transporting.

### Guardrail, disassembling

- 1 Stop the engine.
- 2 Move the control lockout lever down.
- 3 Loosen the mounting screws and disassemble guardrails (A).

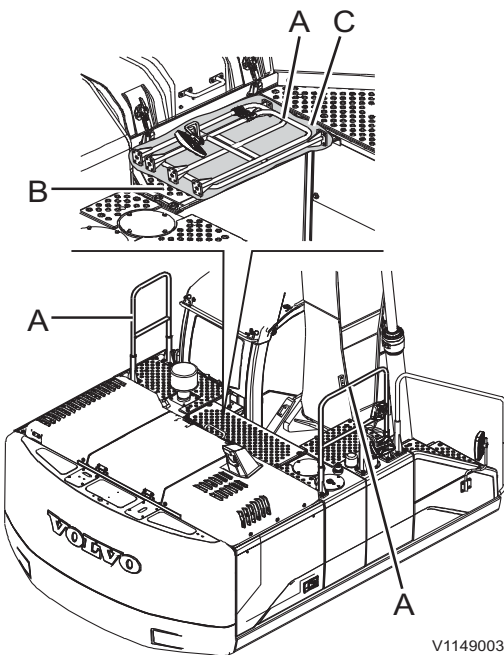

- A Guardrails
- B Main control valve cover
- C Soft protection material

### CAUTION

Risk of injury.

Lifting heavy objects by hand could lead to serious crushing and back injury.

**Use an appropriate lifting device when lifting heavy objects.**

- 4 Store the guardrails on the main control valve cover (B) and tie up together not to release them when transportation.

### NOTE!

Spread a soft protection material (C) between the guardrails and the cover to avoid scratch, crack or other damage.

### Sunlight protection, closing

The sunlight protection may be opened while transporting the machine because of vibration. Therefore it should be closed tightly not to be opened.

### Satellite antenna, folding (optional equipment)

When transporting the machine or using the machine in an area limited the height, the satellite antenna can be damaged.

Fold satellite antenna (A) using spring (B) like the figure. In this case, it may be limited for satellite communication of the machine.

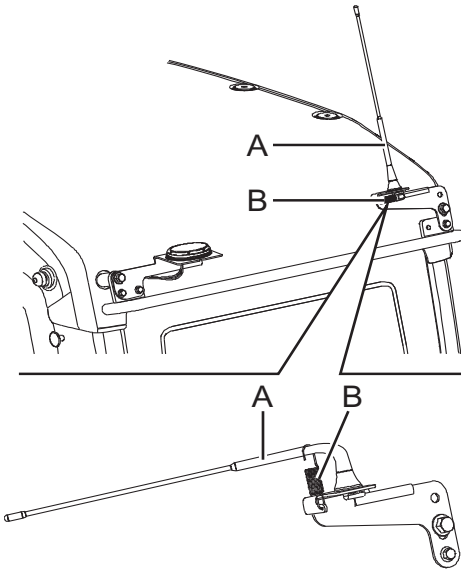

V1099532

- A Satellite antenna
- B Spring

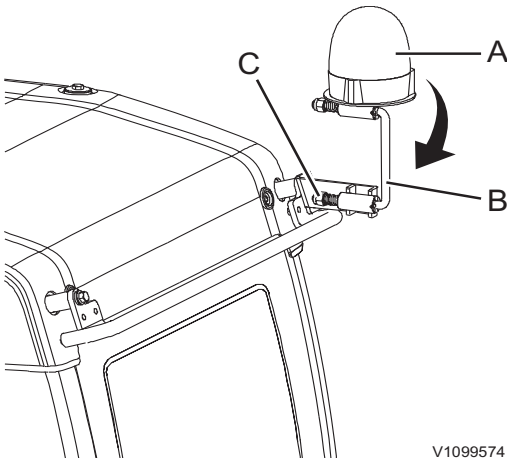

V1099574

### Rotating beacon lamp, folding (optional equipment)

When transporting the machine, fold bracket (B) with rotating beacon lamp (A) not to be damaged.

- 1 Loosen screw (C) and then turn down rotating beacon lamp (A).
- 2 Fasten the screw (C).

200 Operating instructions  
Transporting machine

## Tying down machine

### WARNING

Risk of crushing.

Material may fall off when loading a vehicle.

**Make sure that no persons are standing near the vehicle while loading.**

### NOTE!

Make sure that loading ramps and platforms are free from oil, mud, ice and similar so that the machine does not begin to slip.

### NOTICE

The function for automatic idling must be deactivated with the button on the keyboard in order to avoid that the speed increases during loading and unloading of the machine.

### NOTICE

Select low engine speed and low travelling speed for loading and unloading the machine.

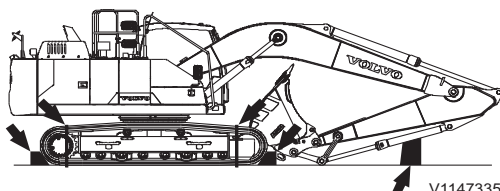
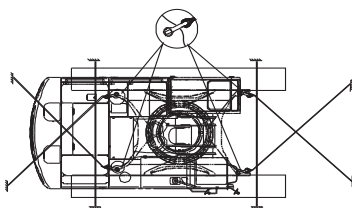
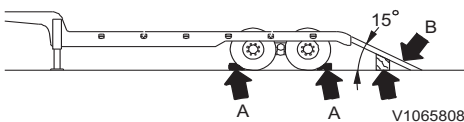

- 1 Place the trailer on a firm and level ground.
- 2 Apply the brake of the trailer.
- 3 Insert blocks (A) in front of and behind the tyres of trailer.
- 4 Fix loading ramps (B) securely.
  - Make sure that the strength, width, length and thickness of the planks are safe for loading.
  - Make sure that the angle of loading ramp is 15° or less.
- 5 Check whether the right and the left loading ramps are of the same height.
- 6 Decide the direction and travel slowly onto the loading ramps and trailer bed / platform. Block each track and secure the machine with tie downs of adequate load rating so that the machine cannot move.
  - Load the machine so that the bucket cylinder rod does not contact the trailer.
  - Never operate any lever other than the travel levers (pedals) while the machine is on the loading ramp.



## Operating instructions Transporting machine 201

---

### **NOTICE**

Do not extend dipper arm or bucket cylinders to their end positions as they then run the risk of being damaged.

- 7 Stop the machine.
- 8 When some parts of machine are disassembled, load the disassembled components on the trailers properly. If necessary, put the blocks behind or below the components.
- 9 Remove the ignition switch.
- 10 Turn OFF the battery disconnect switch.
- 11 Lock the door and the access covers.
- 12 Cover the exhaust pipe to prevent turbocharger from damage.
- 13 Ensure that the machine or disassembled components are firmly secured.

202 Operating instructions  
Transporting machine

## Lifting machine

### WARNING

Risk of personal injury.

Faulty or improper lifting equipment could cause the machine to break away from the lifting vehicle, causing accidents, serious injury or death.

**Use certified cables, lifting straps, slings, shackles and hooks with adequate load capacity and never lift the machine with a person in or on the machine.**

### WARNING

Risk of crushing.

Falling load could cause serious injury.

**Do not stand under a suspended load. Use appropriate loading and lifting equipment.**

### NOTE!

Incorrect or faulty equipment or improper lifting methods may cause accidents. Therefore, carefully follow the instructions given below.

Lift the machine on flat, even and level ground.

- 1 Start the engine, and arrange the bucket, dipper arm and boom as illustrated. Position the superstructure boom forward over the idlers.
- 2 Move the control lockout lever down to lock the system securely, see page 109.
- 3 Stop the engine, check the safety around the machine.
- 4 Close and lock the windshield, cab door and engine hood securely.
- 5 As shown in the decal for lifting, connect lifting cables or slings with sufficient strength for the machine weight at the lifting points correctly.
- 6 After installation of all hoisting equipment, lift the machine a little to check its balance, if satisfactory, lift it slowly and evenly.
- 7 Maintain good visibility of the machine at all times during the lift. And continuously check that the machine is level.

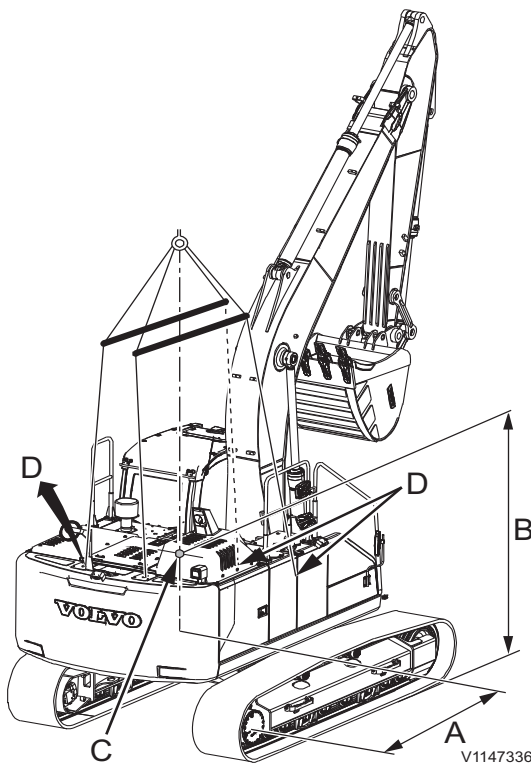

- A 1430 mm (56 inches)
- B 1750 mm (69 inches)
- C Center mark for the center of gravity
- D Lifting points



---

## Operating techniques

The excavator is a multi-task machine capable of being fitted with multitude special attachments to perform many types of work. This chapter contains information and instructions regarding the best operating practices to improve efficiency, including examples on how the most common attachments are used. It is important that the correct technique is used to obtain safe and efficient use of the machine.

## Whole-body vibrations

Whole-body vibration emission on construction machinery are affected by a number of factors, such as working mode, ground conditions, speed, and so on.

To a large extent the operator can influence the actual vibration levels, because the operator controls the speed of the machine, its working mode, the travel path, and so on.

Therefore, the result can be a range of different vibration levels for the same type of machine. For cab specifications, see page 365.

### Guidelines for reducing vibration levels on earthmoving machines

- Use the proper type and size of machine, with optional equipment and attachments for the application.
- Keep the terrain and haul roads in good condition.
  - Remove any large rocks or obstacles.
  - Fill any ditches and holes.
  - Provide equipment and schedule time to maintain terrain conditions.
- Adjust the speed and travel path to minimize the vibration level.
  - Drive around obstacles and rough terrain conditions.
  - Reduce the speed when it is necessary to go over rough terrain.
- Maintain machines according to the manufacturer's recommendations.
  - Track tensions. (crawler machine only)
  - Tire pressures. (wheel machine only)
  - Brake and steering systems. (wheel machine only)
  - Controls, hydraulic system and linkages.
- Keep the seat maintained and adjusted.
  - Adjust the seat and its suspension according to the weight and size of the operator.
  - Inspect and maintain the seat suspension and adjustment mechanisms.
  - Use the seat belt and adjust it correctly.



## Operating techniques Whole-body vibrations 205

---

- Steer, brake, accelerate, shift gears, and move the attachments smoothly. (wheel machine only)
- Minimize vibrations for long work cycle or long distance travelling.
  - Use suspension systems if available.
  - If no suspension system is available, reduce speed to prevent bouncing.
  - Transport machines when there are long distances between worksites.

Back pain associated with whole-body vibrations may be caused by other risk factors.

The following guidelines can be effective to minimize risks of back pains:

- Adjust the seat and controls to achieve good posture.
- Adjust the mirrors to minimize twisted posture.
- Provide breaks to reduce long periods of sitting.
- Avoid jumping down from the machine.
- Minimize repeated handling and lifting of loads.
- Maintain reasonable weight and physical condition.



## Rules for digging

### **WARNING**

Risk of serious injury.

More than one person in the cab while operating could cause accidents and serious injury.

**Only the operator, seated in the operator's seat, may be in the cab when operating. All other persons must keep at a safe distance from the machine.**

First read the safety rules for operating, see pages 167, 168, 169, and 171.

- Always prepare work by carefully studying drawings and regulations that apply to the site. Also study the ground conditions and what the risk areas on the site look like. Turn off gas, electricity and water supplies, if this is necessary. Mark the position of cables and pipes.
- Fence off the area around the machine, if there is a risk that people may get too close. Pay attention to a swinging machine.
- Look after your workmates! Make sure that they take care. No persons, apart from the operator, may be present within the working area of the machine. Teach them to be on their guard against collapsing banks and rolling stones and to be prepared to dash for safety. Changes in stress in a bank immediately prior to a landslide are indicated by small streams of loose material just where the cracks are forming.
- If the machine is provided with optional equipment, which is operated with the pedals, the operator must assure him or her self of that the anticipated movements are obtained when actuating the pedals. An unexpected movement may entail risk of an accident.
- A cab provided with protective grill over the roof window meets the requirements for falling object guard in accordance with stated testing methods (FOPS/ISO 10262). Use the falling object guard when there is risk of heavy, falling objects.

## NOTICE

With certain attachment combinations there is a risk that the attachment may strike the cab. Avoid damage by being careful when working close to the machine.

- Never swing the bucket or load above people.
- Never use the bucket for chopping.
- If uncontrolled movements should occur, first release levers and pedals, then shut off the engine immediately by turning the ignition switch to the stop position.
- If red warning lamps light up and/or the buzzer is sounding, the engine must be stopped immediately and the cause investigated.
- The machine must not be equipped with a larger bucket/attachment than permitted.
- When using equipment which generate knocks or vibrations, for example hammer, the hydraulic cylinders must not be operated closer than 10 cm (4 in) from their end-of-stroke positions.
- In case of fire, the battery disconnect switch should be turned off, if possible. See page 266.

## Loading on to a vehicle

### WARNING

Risk of crushing.

Material may fall off when loading a vehicle.

**Make sure that no persons are standing near the vehicle while loading.**

- If possible, position the machine higher than the vehicle to be loaded.
- Place the vehicle to be loaded so that the machine does not have to swing and lift more than necessary.
- Make sure that the driver of the vehicle to be loaded stays outside the working area of the machine and never swing the bucket over the cab of the vehicle to be loaded.
- Do not load the vehicle unevenly and avoid unnecessary spillage when loading. Do not make the load so high that earth and stones fall over the platform sides.
- Release the load carefully.



**When working, do not:**

- use the swing force for raking over the ground, demolition of buildings or thrusting bucket teeth into the ground. It may cause damage to the machine and attachments.
- dig by using the travelling motors or thrusting bucket teeth into the ground. This can overload the rear of the machine and damage the track drive.
- extend the hydraulic cylinder to its end of stroke. This can overload the stop in the cylinder and shorten the life span of the machine. Work with as much clearance as possible.
- work by slamming the bucket into the ground. Do not perform digging by dropping the boom, or using the bucket instead of a pick. Striking digging or continuous striking can overload the rear of the machine or damage the attachment. It is also very dangerous.
- carry out lifting work. Basically, using this machine as a crane is prohibited. However, local or national regulations may allow it on some markets. If permitted, a properly installed rated bucked hook and certified slings / shackles are required. Contact a workshop authorised by Volvo Construction equipment.
- operate by dropping the machine body.

## Working within dangerous areas

- Observe great care at marked danger areas.
- Do not operate too close to the edge of a quay, ramp, ditch and so on.
- Move slowly when working in confined spaces and check that there is sufficient room for machine and load.
- When working under ground, special equipment, for example certified engine is required within the EU and in EES countries. Talk to your dealer.
- When working in low light conditions, for example buildings and tunnels, use head light.
- Do not operate the machine when visibility is poor such as a heavy fog, snow or rain.
- When working in an area which is contaminated or dangerous to one's health, the machine must be especially equipped for this purpose. Talk to your dealer. Check also local regulations before entering the area.

## High voltage overhead power line

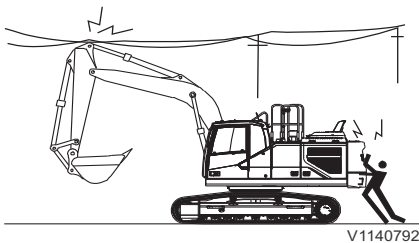

**! DANGER**

Risk of electrocution  
Working near or making contact with overhead power lines may lead to electrical flashover and electrocution.

**Always keep the minimum clearance from overhead power lines.**

**! DANGER**

Risk of electrocution.  
Contact with live parts will cause death or serious injury.

**Never touch live electrical parts.**

210 Operating techniques  
Working within dangerous areas

High voltage is lethal and the current sufficiently strong to destroy both machine and attachments. Your life is in danger if you come into contact with or close to high voltage power lines. Always contact the power company responsible before beginning any work near high voltage power lines. Go through the special instructions issued by the power company for work/presence near the power lines. Regard all power lines as if they were live even if they are supposed to be without current. Working when the machine or its load at any time is closer than the minimum safety distance to a power line, is taking a very serious risk.

- Remember that the voltage of the power line determines the safety distance. Electrical flash-over may occur and damage machine and operator at fairly great distances from the power line.

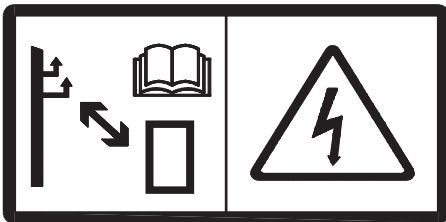

V1079478

Voltage	Minimum distance to power line
0 ~ 50 kV	3 m (10 ft)
50 ~ 69 kV	4.6 m (15 ft)
69 ~ 138 kV	5 m (16.4 ft)
138 ~ 250 kV	6 m (20 ft)
250 ~ 500 kV	8 m (26 ft)
500 ~ 550 kV	11 m (35 ft)
550 ~ 750 kV	13 m (43 ft)
750 kV~	14 m (46 ft)

**NOTICE**

The operator should have secure visibility when working around the power lines.

**NOTICE**

When transporting the machine also take overhead power lines into consideration.



## Operating techniques

# Working within dangerous areas 211

---

### **NOTICE**

**Remember that the roof window may distort how distance is perceived.**

- Keep the following in mind to ensure safety when operating.
  - Operate the machine slower than normal operation in the vicinity of power lines.
  - Consider the long-span power line, which can sway and reduce the clearance.
  - Pay attention when travelling over uneven ground that could cause the machine to lose balance.
  - Keep all persons away from the machine whenever it is close to power lines.
  - Prohibit persons from touching the machine or its load before it is confirmed to be safe.
- Find out what action to take if a person has been exposed to an electric shock.
- Procedure if a machine touches the power line.
  - The operator should stay inside the cab.
  - All other persons should keep away from the machine, ropes, and load.
  - The operator should try to remove the machine from contact by moving it in the reverse direction from that which caused the contact.
  - If the machine cannot be moved away from contact, the operator should remain inside cab until the lines have been de-energized.

212 Operating techniques  
Working within dangerous areas

---

### Overhead railway power lines



Risk of electrocution

Working near or making contact with overhead power lines may lead to electrical flashover and electrocution.

**Always keep the minimum clearance from overhead power lines.**



Risk of electrocution.

Contact with live parts will cause death or serious injury.

**Never touch live electrical parts.**

Loading and unloading is only permissible between the boundary signs. The signs may be mounted directly on the power line or on special posts.

- Contact authorised railway personnel to obtain permission to load or unload.
- After any breaks in the work, always contact the railway personnel again.



## Underground cables and pipes

Make sure that authorities or companies responsible for cables and pipes have been contacted and that their instructions are followed. Also check which rules apply to ground personnel regarding exposing cables and pipes. Normally only the service companies' own personnel may expose and arrange provisional suspension of cables. Make use of a signal man when you cannot see the actual point where you are working or when the position of the pipe or cable is critical, see page 258. The position of the pipe or cable may deviate from the drawing or distances may be incorrectly determined. Regard all electrical cables as live.



## 214 Operating techniques Working within dangerous areas

### Working on slopes

#### NOTICE

In order not to jeopardise the lubrication of the engine, the machine must not be inclined more than 35 degrees in either direction. In addition it may be unsuitable to operate at this inclination as the machine may become unstable and unbalanced, depending on the load.

#### Caution on a slope

- Be careful when opening or closing the doors on a slope, operational force may be changed rapidly. Make sure to keep the doors closed.
- Do not descend backward on a slope.
- Operate the travel function slowly when approaching or descending a slope.
- Do not change direction or travel a cross on a slope. Change direction on level ground, if necessary first come down to level ground and make a detour.
- If the machine slides, immediately lower the bucket to the ground. The machine can turn over due to unbalance. Especially, do not swing with loaded bucket. In unavoidable case, pile up earth on the slope, and then make the machine level and stable.
- While travelling on a slope, keep the angle between boom and dipper arm at 90 - 110 °, raise the bucket 20 - 30 cm from the ground
- While travelling down on a slope, keep the angle between boom and dipper arm at 90 - 110 °, raise the bucket 20 - 30 cm from the ground and travel at low speed.

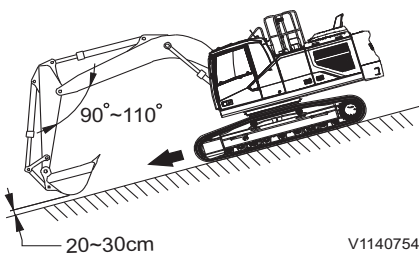
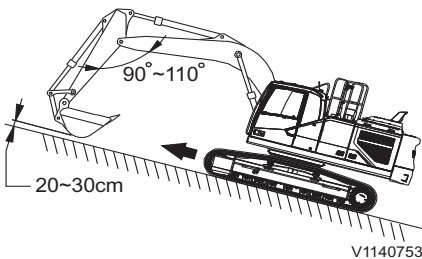
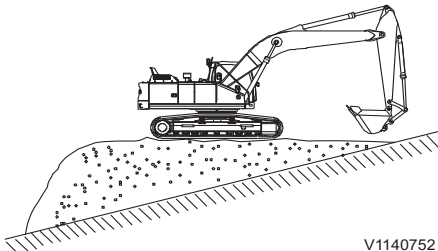
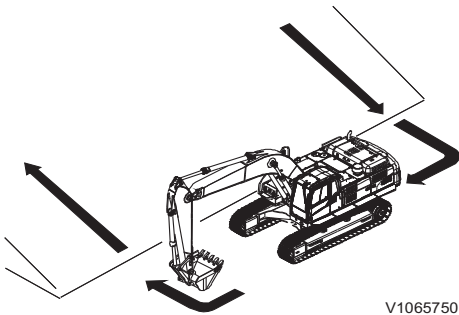

## Operating techniques

# Working within dangerous areas 215

---

### In case of shoes slipping

If the shoes slip on a slope, thrust bucket into the ground, and pull the dipper arm in to assist the track drive to move the machine up the slope.

### In case of engine failure

In case of engine shut down while travelling on a slope, put the travel lever to neutral position and lower bucket down to the ground, then start the engine.

If the engine shuts down on a slope, do not operate the swing function, since the superstructure may be swung under its own weight and cause tipping or side slipping.

### Travelling on uneven ground

- In case of travelling on uneven ground, reduce travel speed and operate the machine so as not to lean to one side more than 10 °.
- In case of travelling on flat ground, retract the attachment and raise it 40 - 50 cm from the ground.

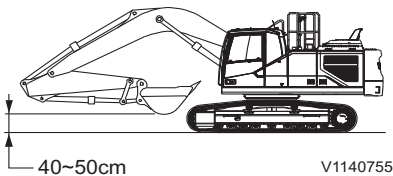
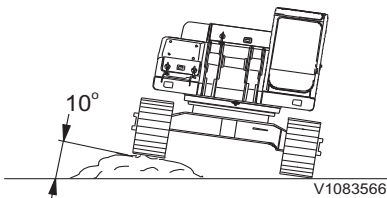

## 216 Operating techniques Working within dangerous areas

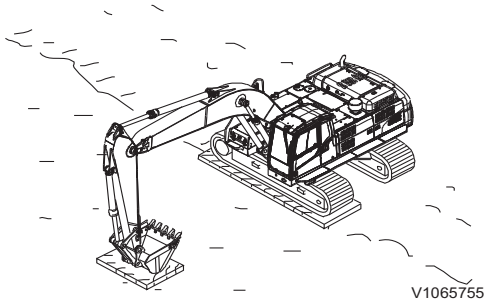

V1065755

### Working in water and on boggy ground

Be very careful when working on boggy ground.

#### In case that one track gets bogged

If one track gets bogged down, raise this track using the bucket and put a plank under the track.

#### NOTICE

When the machine is lifted with the aid of the boom or the dipper arm, the bottom of the bucket should rest on the ground not the bucket teeth.

Set the angle between boom and dipper arm at  $90^\circ \sim 110^\circ$ .

After working in water or escaping from boggy ground, replenish the grease to the attachment pins or the areas affected by the water. Check the idler, rollers and track drive case oil, if contaminated, change the oil.

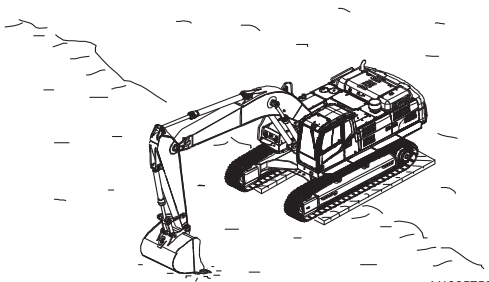

V1065756

#### In case both tracks get bogged

In case that both tracks get bogged down, put planks under each track. Thrust the bucket into the ground, pull with the dipper arm as when digging, and move the travel lever forward to escape.

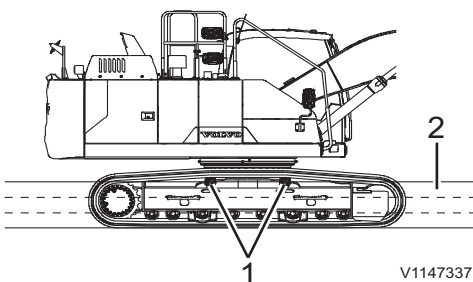

V1147337

- 1 Top roller
- 2 Water level

### Permissible depth of water

#### NOTICE

Pay attention to the permissible water depth in order to avoid damage to the machine.

Permissible working depth in water is the center of top rollers.

Do not fully submerge the top rollers.

Upon leaving the water, make sure all the grease is replenished in the areas affected by the water, for example bucket pin and so on, remove the old grease completely regardless of the maintenance period. Also check the oil in the travel drive for contamination, and if necessary, replace it.

## Working in cold weather

### DANGER

Risk of electrical shock.

Personal injury results if a body part comes into contact with a machine that conducts electric power.

**Disconnect the electrical engine heater before working on the machine.**

### WARNING

Risk of frostbite.

Bare skin can freeze stuck to cold metal which could cause injury.

**Use personal protective equipment when handling cold objects.**

### WARNING

Risk of crushing injury.

The hydraulic system could respond slowly at low temperatures and could cause unexpected machine movements.

**Operate carefully until the hydraulic system has reached operating temperature.**

Read the advice for starting, see page 173.

Use appropriate fluids for the ambient working temperatures. (see recommended fluids in specification section.)

The windows must be free from ice and snow before putting the machine to work.

- Watch out for ice on the machine causing slippery conditions. Step only onto anti-slip surfaces.
- Use an ice scraper on a long handle or a ladder when removing ice from the windows.

## 218 Operating techniques Working within dangerous areas

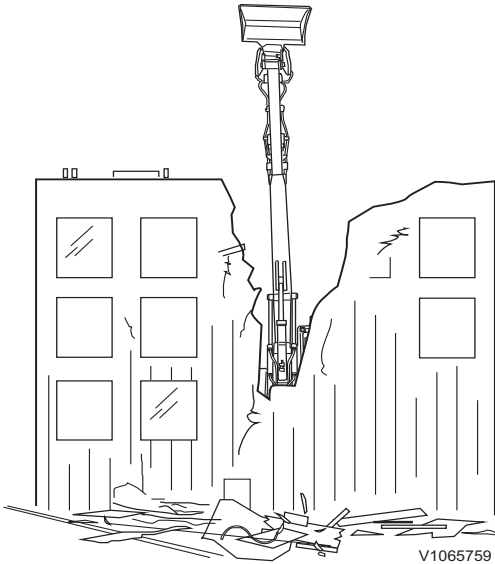

### Demolition work

The machine is often used for demolition work. Be extremely careful and study the work site thoroughly. Use fall protection over the cab against falling objects.

- Make sure that the material, on which the machine is standing, cannot collapse or slide.
- Operate the machine on firm level ground, if necessary prepare the area with another machine first.
- Do not work close to free-standing walls, which may fall over the machine.
- At all times be aware of where your workmates are. Do not work if anyone is dangerously close to the demolition object.
- Leave sufficient space in front of the machine for debris to fall to the ground and not hit the cab.
- Fence off the dangerous part of the work site.
- Spray water over the demolition site to prevent harmful dust from spreading.

Boots with steel reinforcements in the soles and toe caps, protective goggles and a hard hat are obvious protective items to be worn on a demolition site.

If the machine is equipped with special demolition equipment, read the supplied instruction booklet about the safety risks that might occur and how the demolition equipment is used.

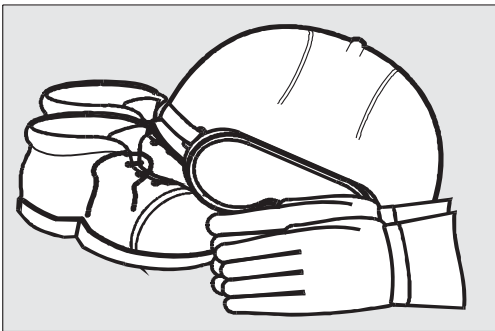

V1067189

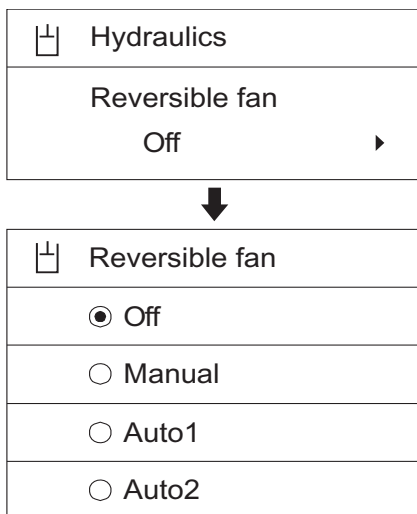

V1137864

## Reversible fan

### (Optional equipment)

The reversible fan is designed to clean the cooling module (clogging net, radiator and oil cooler fins), maintain the cooling performance and also extend the cleaning interval.

### Modes and setting

The reversible fan is set up by the IC (Instrument Cluster) menu as one of "Off", "Manual", "Auto1", "Auto2" mode. It also allows the operator to select a reversible fan mode. The "Off" mode is set up as default initially.

- **Off mode:** Maintain normal rotation or revert to "Off" mode by stopping reverse rotation. Also selecting the "Off" mode during the "Manual" mode cancels the reverse rotation and returns to previous setting mode.
- **Manual mode:** Reverses the rotation one cycle immediately after setting the mode. After finishing the "Manual" mode, returns to the previous setting mode. Reverse rotation time is set up as 60 seconds and changeable between 20 to 180 seconds by Volvo's service tool. Contact a workshop authorized by Volvo.
- **Auto1 mode:** Repeats a cycle consisting of normal rotation and reverse rotation. Normal rotation time is set up as 60 minutes and changeable between 20 to 120 minutes by Volvo's service tool. Contact a workshop authorized by Volvo. Reverse rotation time is set up as 20 seconds and not changeable.
- **Auto2 mode:** Repeats a cycle consisting of normal rotation and reverse rotation. Normal rotation time is set up as 20 minutes and not changeable. Reverse rotation time is set up as 20 seconds and not changeable.

### NOTE!

The reversible fan indicator is shown on the indicator screen of IC (Instrument Cluster) during reverse rotation.



V1068779

## Attachments

### Boom float position, description

Float position means that both the boom cylinders' piston and piston rod sides are connected to the hydraulic tank. The boom then floats with the weight of the attachments when operating the boom lever forward. The boom lifting is not affected by float position.

Float position gives better fuel economy, faster excavation cycle, less wear and less vibration. When the float position is engaged, the hydraulic oil of the machine can be used for other purposes than lowering the boom, such as the dipper arm and/or bucket operation. These functions then become faster and more efficient.

#### Keep the following in mind.

- Always make sure that the boom operating lever is in the neutral position before activating the float position.
- Do not select the float position mode while the track or tracks are elevated. Selecting the float position mode and operating the boom operating lever forward (boom down position) while the track or tracks are elevated could cause the machine to drop down suddenly.
- Do not release float position mode while the boom operating lever forward (boom down position) and bucket or tool is on the ground. This could cause the machine to tilt up suddenly.
- Do not attempt to lift the track or tracks while the machine is in float position mode.





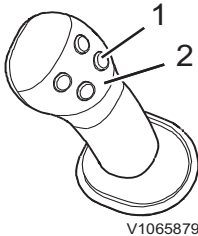

V1065879

- 1 Float On / Off button
- 2 Control lever with four buttons



V1065880

Indicator on the instrument panel

Use the float position when the attachment has to follow the irregular ground, such as for bedrock clearance, grapple handling and when unloading barges and flatbeds. Float position also makes unloading more manageable.

- 1 Select the float position using button 1 on the right control lever in order to activate the float function. The control lever should have the float function, see page 94. The float operation indicator on the front instrument panel lights up.
- 2 Float position is only in operation when you push the boom operating lever forward. When the attachment is to follow the ground, the boom operating lever must therefore be held forwards all the time. The boom can then move upward and downward freely depending on the state of the ground.
- 3 Deactivate the float position by pressing the button 1 again. The indicator on the instrument panel will go out.

**NOTE!**

When the boom float function is on, the function will remain even if the ignition switch is off and on again. The indicator on the instrument panel will be also displayed.



## Attachments, connecting and disconnecting

### Attachment quick coupler

S type quick coupler, S1 and S2 (optional equipment)

#### WARNING

Risk of crushing.

Falling attachments could result in severe injury or death.

**Make sure the attachment bracket is properly locked before starting work.**

#### WARNING

Risk of crushing.

An unsecured attachment could fall and cause serious injury or death.

**Always ensure the attachment is properly secured by pressing the front part of the attachment to the ground until the machine is slightly lifted.**

The attachment quick coupler consists of flat mounting plates which are attached to the end of dipper arm and bucket link. There are two hooks (F) on the plate for the pins (B) on the bucket.

There is a lift hook (C) on the attachment quick coupler.

The attachment quick coupler is equipped with a double-acting hydraulic cylinder. The quick coupler's lock wedge (D) is fitted to its piston rod. Servo pressure acts on the piston of the lock cylinder, locking the bucket in place against rear hook (E). This means that the lock wedge adjusts itself and provides gap-free locking.

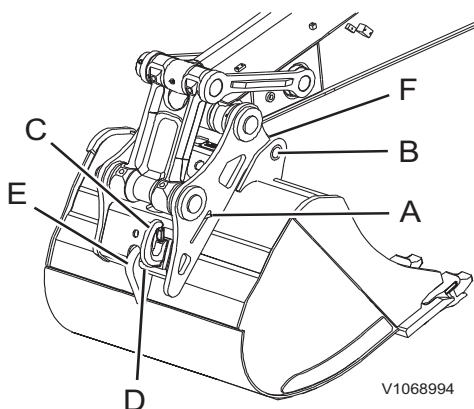

- A Red indicator pin
- B Bucket pins
- C Lift hook
- D Lock wedge
- E Bucket rear hook
- F Hooks for gripping attachment

## Operating techniques

# Attachments, connecting and disconnecting 223

When the lock wedge (D) is released, the servo pressure is transferred to the piston rod side. If necessary, the release pressure can be increased by loading the bucket cylinder in its end position.

There is a red indicator pin (A) on the left side of the quick coupler, which is pulled in when the lock wedge is in the locked position and pushed out when the lock wedge is released.

With the lift hook, the machine can be used for lifting operations. Since the hook is located on the attachment quick coupler, it can be used without bucket. This improves visibility for the operator and increases the maximum permissible load.

### NOTE!

See page 252 for information on lifting objects.

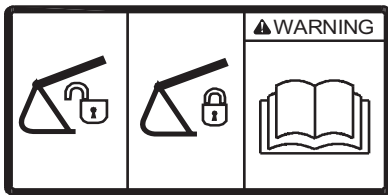

V1065833

### **WARNING**

The attachment quick coupler may be open regardless of what is indicated by the alarm signal or on the instrument panel. Therefore, always check that the attachment quick coupler is locked securely. Also read the instructions in the operator's manual.

### **WARNING**

Risk of crushing.

If the pressure in the attachment quick coupler cylinder drops, the attachment could fall off and cause serious crushing injury or death.

**Never install shut-off valves in the lines leading to the cylinder for the attachment quick coupler.**

## 224 Operating techniques Attachments, connecting and disconnecting

### Bucket, removing

#### **WARNING**

Risk of crushing!

Attachments that move unexpectedly can cause injuries.

**Make sure people stay out of the working area when connecting or disconnecting attachments.**

- 1 Position the machine on even, firm and level ground with the bucket resting on the ground.
- 2 Press down to release the red lock device (A) on the right attachment quick coupler switch and then press the switch to position (1) to initiate the attachment quick coupler.

When the attachment quick coupler is initiated, the buzzer sounds and the check message and indicator are displayed on the IC (Instrument Cluster). See page 79 for more information.

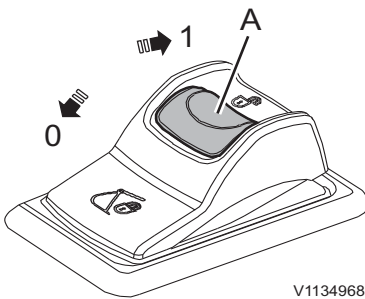

Attachment quick coupler switch, right

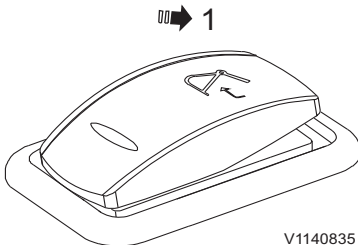

Attachment quick coupler switch, left

- 3 Press the left attachment quick coupler switch for more than 0.7 seconds to open the attachment quick coupler. The switch is returned automatically. See page 35 for more information.

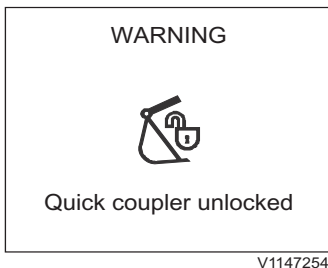

Warning! Quick coupler unlocked

#### **NOTE!**

When the attachment quick coupler is open, the buzzer sounds and the warning message and indicator are displayed on the IC (Instrument Cluster).

## Operating techniques

# Attachments, connecting and disconnecting 225

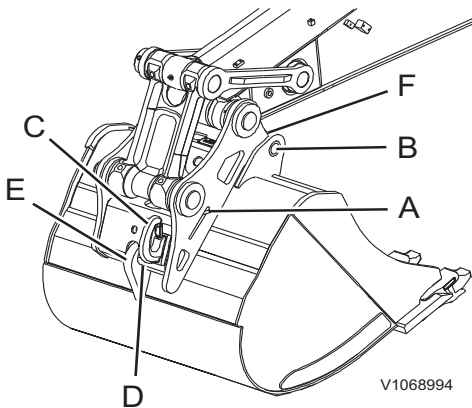

- A Red indicator pin
- B Bucket pins
- C Lift hook
- D Lock wedge
- E Bucket rear hook
- F Hooks for gripping attachment

- 4 When the red indicator pin (A) on the quick coupler is extended completely, carefully release the bucket from the attachment quick coupler by operating the bucket cylinder to its inner end position (bucket out).

**NOTE!**

If the red indicator pin (A) is not extended, increase the hydraulic pressure to the lock cylinder by carefully moving the bucket cylinder to its outer end position (bucket in), and keeping it under pressure for about a second.

- 5 Disconnect the bucket by extending the dipper arm and raising the boom.

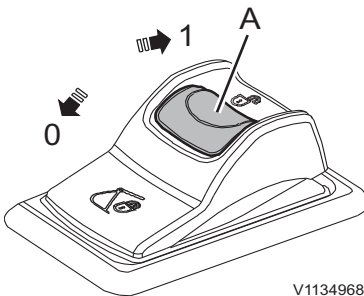

Attachment quick coupler switch, right

- 6 Press the right attachment quick coupler switch to position (0) to close the attachment quick coupler. See page 79 for more information.

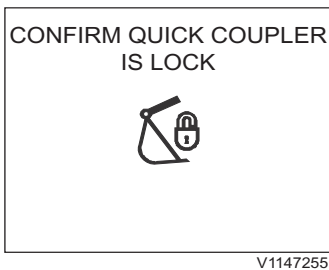

Confirm quick coupler is locked

**NOTE!**

When the switch is in position (0), the buzzer sounds and the check message for confirming and indicator are displayed on the IC (Instrument Cluster).

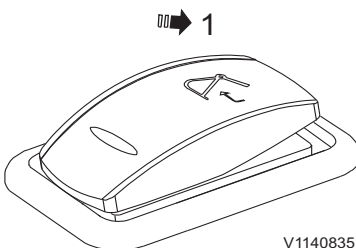

Attachment quick coupler switch, left

- 7 Press the left attachment quick coupler switch for more than 0.7 seconds to confirm that the attachment quick coupler is locked. Then the buzzer sound will be turned off and the check message and indicator will disappear. See page 35 for more information.

## 226 Operating techniques Attachments, connecting and disconnecting

### Bucket, installing

#### **WARNING**

Risk of crushing!

Attachments that move unexpectedly can cause injuries.

**Make sure people stay out of the working area when connecting or disconnecting attachments.**

- 1 Position the machine on even, firm and level ground.
- 2 Press down to release the red lock device (A) on the right attachment quick coupler switch and then press the switch to position (1) to initiate the attachment quick coupler.

When the attachment quick coupler is initiated, the buzzer sounds and the check message and indicator are displayed on the IC (Instrument Cluster). See page 79 for more information.

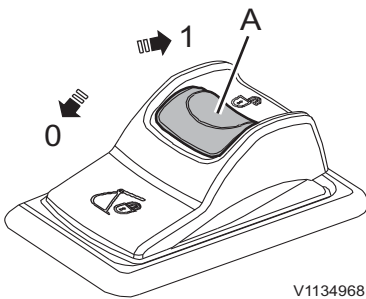

Attachment quick coupler switch, right

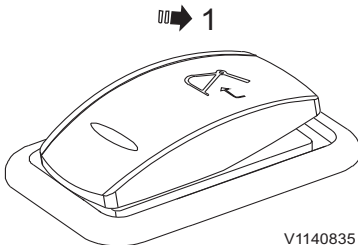

Attachment quick coupler switch, left

- 3 Press the left attachment quick coupler switch for more than 0.7 seconds to open the attachment quick coupler. The switch is returned automatically. See page 35 for more information.

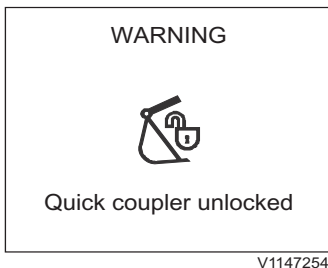

Warning! Quick coupler unlocked

#### **NOTE!**

When the attachment quick coupler is open, the buzzer sounds and the warning message and indicator are displayed on the IC (Instrument Cluster).

## Operating techniques

# Attachments, connecting and disconnecting

## 227

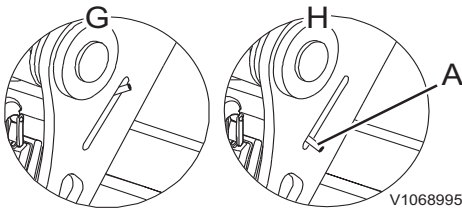

- G Indicator pin fully retracted : lock position
- H Indicator pin fully extended : unlock position
- A Red indicator pin

- 4 Check that the red indicator pin (A) is fully extended.

**NOTE!**

If the red indicator pin (A) is not extended, increase the hydraulic pressure to the lock cylinder by carefully moving the bucket cylinder to its outer end position (bucket in), and keeping it under pressure for about a second.

- 5 Operate the dipper arm to such a position that the two hooks on the attachment quick coupler engage the bucket's front pin.
- 6 Slowly turn the attachment quick coupler towards the bucket by moving the bucket cylinder (bucket in) until the quick coupler mates correctly against the bucket.
- 7 Check that the attachment quick coupler is correctly aligned against the tip of the bucket, if necessary, adjust with dipper arm or boom movements.
- 8 Press the right attachment quick coupler switch to position (0) to close the attachment quick coupler. See page 79 for more information.

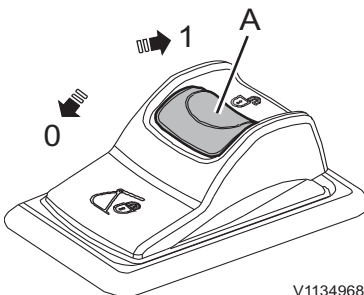

V1134968

Attachment quick coupler switch, right

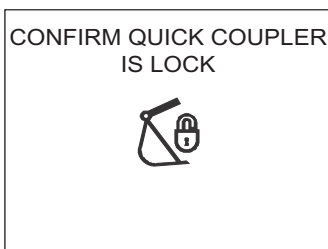

V1147255

Confirm quick coupler is locked

**NOTE!**

When the switch is in position (0), the buzzer sounds and the check message for confirming and indicator are displayed on the IC (Instrument Cluster).

## 228 Operating techniques Attachments, connecting and disconnecting

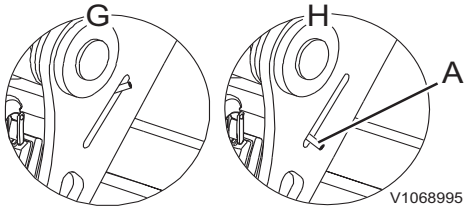

- G Indicator pin fully retracted  
: lock position
- H Indicator pin fully extended  
: unlock position
- A Red indicator pin

9 Check that red indicator pin (A) is fully retracted into the attachment quick coupler.

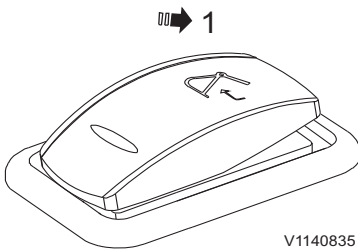

Attachment quick coupler switch, left

10 Press the left attachment quick coupler switch for more than 0.7 seconds to confirm that the attachment quick coupler is locked. Then the buzzer sound will be turned off and the check message and indicator will disappear. See page 35 for more information.

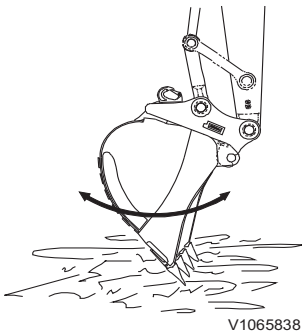

11 Do the following tests to check that the attachment quick coupler is fastened securely.

- Press the bucket against the ground.
- Operate the bucket cylinder in and out to check that lock wedge (D) is seated securely. If you are not sure, check that lock wedge (D) has gone into the hook.
- Do not use the machine if the attachment quick coupler is not working.
- Contact a workshop authorized by Volvo if anything is wrong.

### WARNING

Risk of crushing.

If the red warning lamp for open attachment bracket lights up while working, the attachment could fall off and cause serious crushing injury or death.

**Stop working with the machine immediately and make sure the attachment bracket is properly locked before starting to work again.**



## Operating techniques Attachments, connecting and disconnecting 229

### S1 quick coupler, adjusting

Periodic checks must be performed on the quick coupler. Check the quick coupler every 10 hours or daily, especially when operating the machine in severe or harsh conditions.

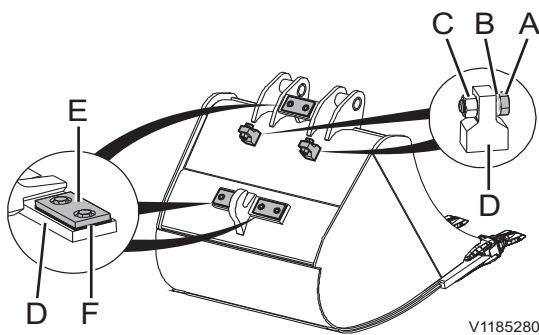

- A Screw
- B Washer + shim
- C Nut
- D Screw holder
- E Spacer
- F Shim

- 1 Remove the bucket, referring to the bucket removal instructions.
- 2 Remove shims (B) between screw holder (D) and screw (A) in 2 places, as shown in the illustration. Replace the screws back in their original positions.
- 3 Remove shims (F) between screw holder (D) and spacer (E) in 3 places, as shown in the illustration. Replace the spacers back in their original positions and tighten the mounting bolts.

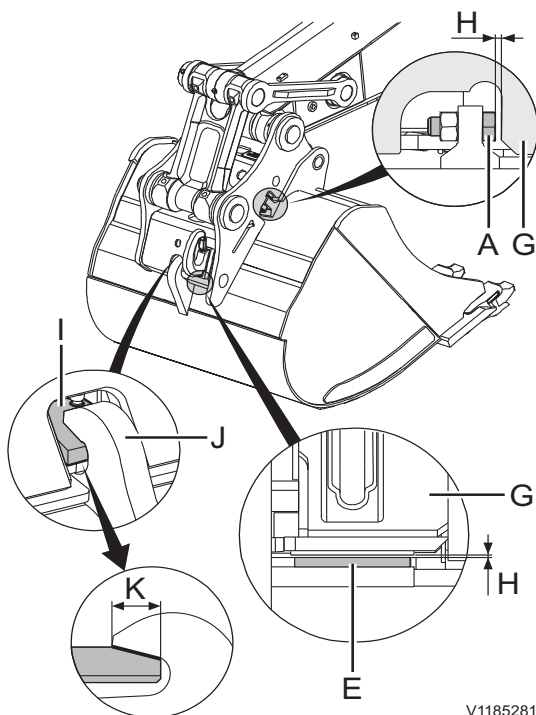

- G Attachment quick coupler
- H Gap
- I Lock wedge
- J Bucket rear hook
- K Recommended length of the mating surface (more than 60 mm (2.4"))

- 4 Install the bucket, referring to the bucket installation instructions.
- 5 Confirm that lock wedge (I) is fully engaged in the mating hook.

#### NOTE!

It is important to check that the lock wedge (I) sinks deep enough down into the hook (J). It is recommended that the lock wedge is engaged into the hook more than 60 mm (2.4") (K). Visually inspect to verify the lock wedge is in the correct position.

- 6 Measure gaps (H) between screws (A) and the corresponding mating surface of the quick coupler (G). Bucket should be gently operated as needed to obtain maximum possible gap and this should be done in each of the 2 places independently.
- 7 Measure gaps (H) between spacers (E) and the corresponding mating surface of the quick coupler (G). Bucket should be gently operated as needed to obtain maximum possible gap and this should be done in each of the 3 places independently.
- 8 Remove the bucket, referring to the bucket removal instructions.
- 9 Unscrew screw (A) and add shims (B) between screw holder (D) and screw for the thickness of





## 230 Operating techniques Attachments, connecting and disconnecting

---

the gap measured in procedure 6. Tighten the screw, and lock it with the nut. Contact your Volvo dealer for information on the correct shims.

10 Unscrew the spacer mounting bolts and add shims between spacer (E) and screw holder (D) for the thickness of the gap measured in procedure 7. Tighten the spacer mounting bolts. Contact your Volvo dealer for information on the correct shims.

11 Install the bucket again and check the gap in the same way as in procedures 6 and 7.

12 If there is still a gap, measure the gap and add the required thickness of shims. Or if the quick coupler cannot hook the bucket completely into its mating surface due to interference, reduce the thickness of shims.

13 Repeat this process until the gap is removed in each of the 5 places between the bucket and quick coupler.

### **NOTE!**

Operating with a bucket not tightly mounted, with a gap, will significantly increase wear and tear on the quick coupler.

## Operating techniques

### Attachments, connecting and disconnecting 231

#### S2 quick coupler, adjusting

Periodic checks must be performed on the quick coupler. Check the quick coupler every 10 hours or daily, especially when operating the machine in severe or harsh conditions.

- 1 Remove the bucket, referring to the bucket removal instructions.
- 2 Remove shims (B) between screw holder (C) and spacer (A) in 5 places, as shown in the illustration. Replace all spacers back in their original positions and tighten the mounting bolts.

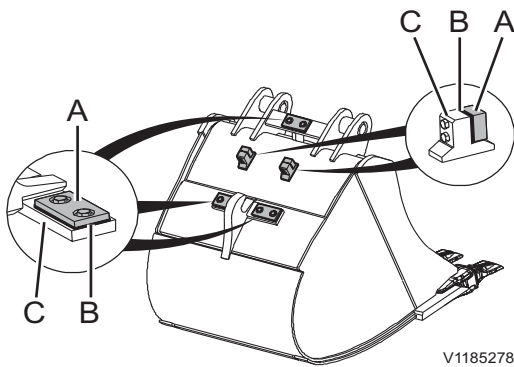

- A Spacer
- B Shim
- C Screw holder

- 3 Install the bucket, referring to the bucket installation instructions.
- 4 Confirm that lock wedge (F) is fully engaged in the mating hook.

**NOTE!**

It is important to check that the lock wedge (F) sinks deep enough down into the hook (G). It is recommended that the lock wedge is engaged into the hook more than 60 mm (2.4") (H). Visually inspect to verify the lock wedge is in the correct position.

- 5 Measure gaps (E) between spacers (A) and the corresponding mating surface of the quick coupler (D). Bucket should be gently operated as needed to obtain maximum possible gap and this should be done in each of the 5 places independently.
- 6 Remove the bucket, referring to the bucket removal instructions.
- 7 Unscrew the spacer mounting bolts and add shims between spacer (A) and screw holder (C) for the thickness of the gap measured in procedure 5. Tighten the spacer mounting bolts. Contact your Volvo dealer for information on the correct shims.
- 8 Install the bucket again and check the gap in the same way as in procedure 5.

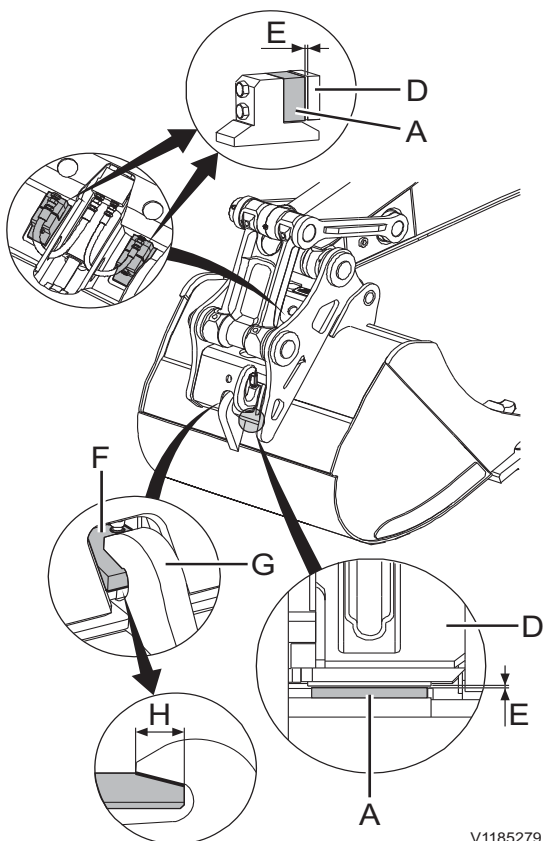

- D Attachment quick coupler
- E Gap
- F Lock wedge
- G Bucket rear hook
- H Recommended length of the mating surface (more than 60 mm (2.4"))



## 232 Operating techniques Attachments, connecting and disconnecting

---

- 9 If there is still a gap, measure the gap and add the required thickness of shims. Or if the quick coupler cannot hook the bucket completely into its mating surface due to interference, reduce the thickness of shims.
- 10 Repeat this process until the gap is removed in each of the 5 places between the bucket and quick coupler.

**NOTE!**

Operating with a bucket not tightly mounted, with a gap, will significantly increase wear and tear on the quick coupler.

## Attachment quick coupler

### Universal quick coupler (optional equipment)

#### **WARNING**

Risk of crushing.

Falling attachments could result in severe injury or death.

**Make sure the attachment bracket is properly locked before starting work.**

#### **WARNING**

Risk of crushing.

An unsecured attachment could fall and cause serious injury or death.

**Always ensure the attachment is properly secured by pressing the front part of the attachment to the ground until the machine is slightly lifted.**

The attachment quick coupler is equipped with a double-acting hydraulic cylinder. The hook for gripping the attachment is fitted to its piston rod. The hydraulic system's pressure acts on the lock cylinder's piston, locking the attachment in place against the rear bucket pin. This means that the hook adjusts itself and provides gap-free locking.

When checking from the cab if the attachment quick coupler is locked or unlocked, slowly curl out the bucket/attachment and dipper arm.

With the lifting eye, the machine can be used for lifting operations. Since the lifting eye is located on the attachment quick coupler, it can be used without bucket. This improves visibility for the operator and increases the maximum permissible load.

#### **NOTE!**

See page 252 for information on lifting objects.

234 Operating techniques  
Attachments, connecting and disconnecting

Bucket, removing

**! WARNING**

Risk of crushing!

Attachments that move unexpectedly can cause injuries.

**Make sure people stay out of the working area when connecting or disconnecting attachments.**

- 1 Place the machine on firm and level ground.
- 2 Curl in the bucket completely towards the dipper arm (to release the lock mechanism).

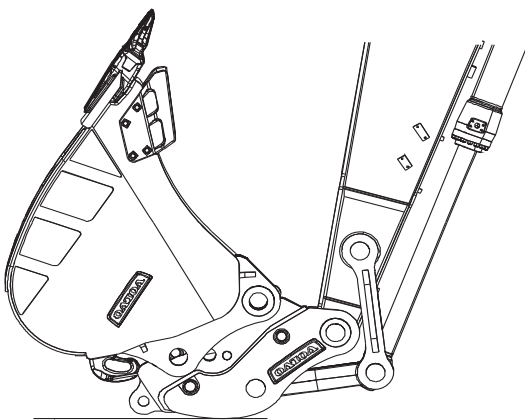

D

V1190909

D = 200 mm (7.87 inches)

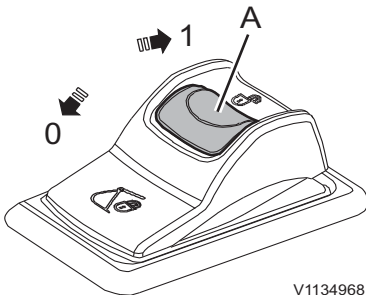

V1134968

Attachment quick coupler switch, right

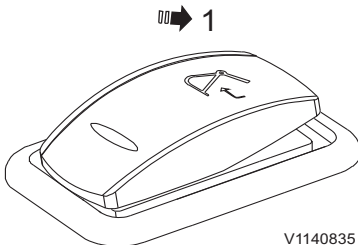

V1140835

Attachment quick coupler switch, left

- 3 Press down to release the red lock device (A) on the right attachment quick coupler switch and then press the switch to position (1) to initiate the attachment quick coupler.

When the attachment quick coupler is initiated, the buzzer sounds and the check message and indicator are displayed on the IC (Instrument Cluster). See page 79 for more information.

- 4 Press the left attachment quick coupler switch for more than 0.7 seconds to open the attachment quick coupler. The switch is returned automatically. See page 35 for more information.

## Operating techniques

# Attachments, connecting and disconnecting 235

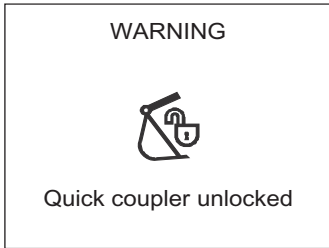

V1147254

Warning! Quick coupler unlocked

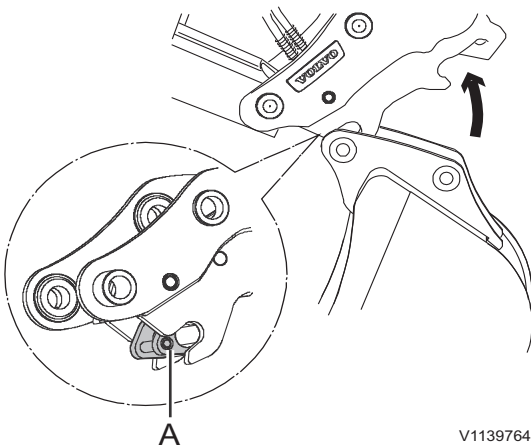

V1139764

Attachment quick coupler, unhooking  
A Front lock device

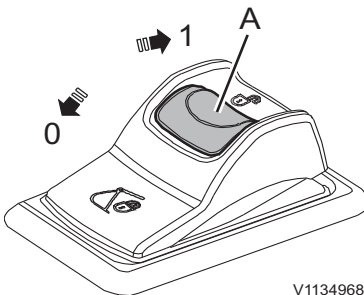

V1134968

Attachment quick coupler switch, right

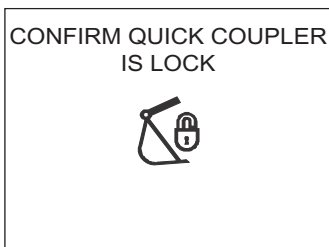

V1147255

Confirm quick coupler is locked

**NOTE!**

When the attachment quick coupler is open, the buzzer sounds and the warning message and indicator are displayed on the IC (Instrument Cluster).

- 5 Make sure that the front lock device (A) is fully opened to unhook from the bucket pin. Otherwise, the bucket pin cannot disengage correctly.

**NOTE!**

If the front lock device (A) is not opened, increase the hydraulic pressure to the lock cylinder by carefully moving the bucket cylinder to its outer end position (bucket in), and keeping it under pressure for about a second.

- 6 Lower the bucket and curl out to lift up the attachment quick coupler from the bucket.
- 7 Place the bucket flat on the ground and unhook it.
- 8 Press the right attachment quick coupler switch to position (0) to close the attachment quick coupler. See page 79 for more information.

**NOTE!**

When the switch is in position (0), the buzzer sounds and the check message for confirming and indicator are displayed on the IC (Instrument Cluster).

## Operating techniques

### 236 Attachments, connecting and disconnecting

---

1

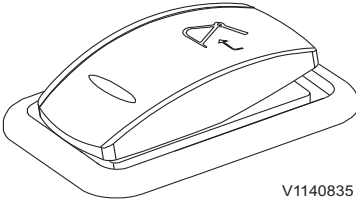

V1140835

Attachment quick coupler switch, left

- 9 Press the left attachment quick coupler switch for more than 0.7 seconds to confirm that the attachment quick coupler is locked. Then the buzzer sound will be turned off and the check message and indicator will disappear. See page 35 for more information.

## Operating techniques

# Attachments, connecting and disconnecting 237

### Bucket, installing

#### **WARNING**

Risk of crushing!

Attachments that move unexpectedly can cause injuries.

**Make sure people stay out of the working area when connecting or disconnecting attachments.**

- 1 Place the machine on firm and level ground.
- 2 Curl in the bucket completely towards the dipper arm (to release the lock mechanism).

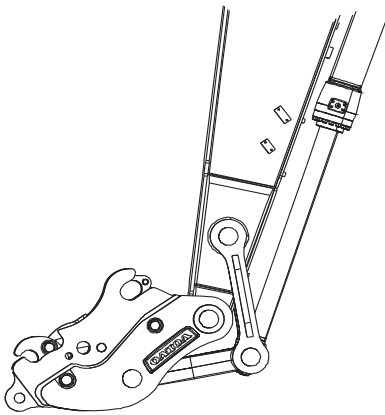

V1190910

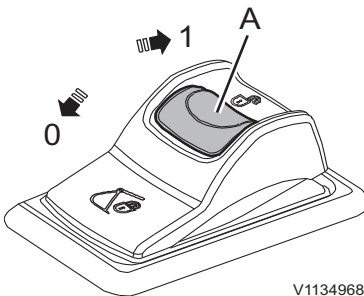

V1134968

Attachment quick coupler switch, right

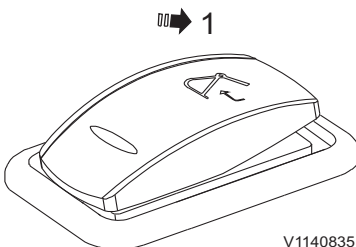

V1140835

Attachment quick coupler switch, left

- 3 Press down to release the red lock device (A) on the right attachment quick coupler switch and then press the switch to position (1) to initiate the attachment quick coupler.

When the attachment quick coupler is initiated, the buzzer sounds and the check message and indicator are displayed on the IC (Instrument Cluster). See page 79 for more information.

- 4 Press the left attachment quick coupler switch for more than 0.7 seconds to open the attachment quick coupler. The switch is returned automatically. See page 35 for more information.



## 238 Operating techniques Attachments, connecting and disconnecting

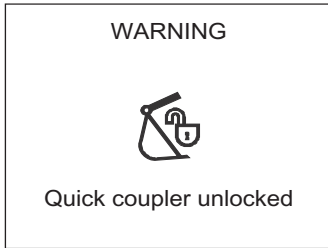

V1147254

Warning! Quick coupler unlocked

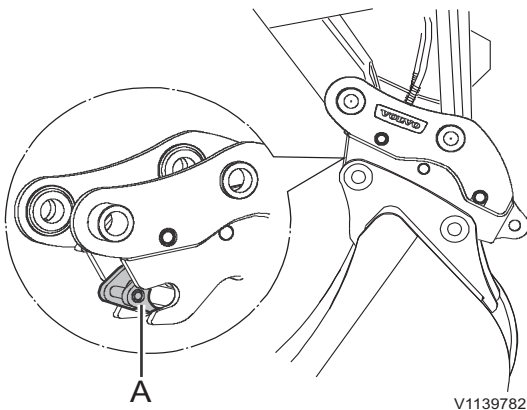

V1139782

Bucket in locked position  
A Front lock device

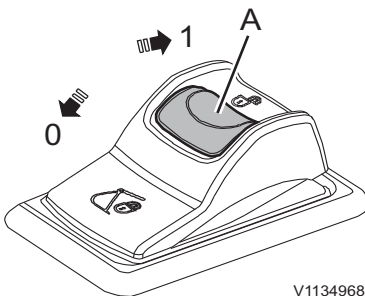

V1134968

Attachment quick coupler switch, right

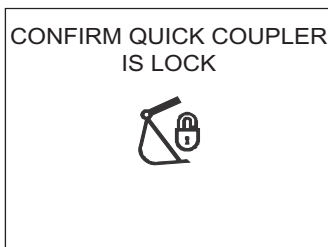

V1147255

Confirm quick coupler is locked

### NOTE!

When the attachment quick coupler is open, the buzzer sounds and the warning message and indicator are displayed on the IC (Instrument Cluster).

- 5 Make sure that the front lock device (A) is fully opened before hooking it onto the bucket pin. Otherwise, the bucket pin cannot be engaged correctly.

### NOTE!

If the front lock device (A) is not opened, increase the hydraulic pressure to the lock cylinder by carefully moving the bucket cylinder to its outer end position (bucket in), and keeping it under pressure for about a second.

- 6 Curl out the attachment quick coupler and hook it onto the bucket pin.
- 7 Slowly curl in the attachment quick coupler fully towards the bucket.
- 8 Press the right attachment quick coupler switch to position (0) to close the attachment quick coupler. See page 79 for more information.

### NOTE!

When the switch is in position (0), the buzzer sounds and the check message for confirming and indicator are displayed on the IC (Instrument Cluster).

- 9 Visually check that the front lock device is fully engaged.
- 10 Lift and curl in the bucket fully towards the dipper arm and hold it there for approximately 5 seconds to ensure that the attachment quick coupler has locked securely to the bucket.

## Operating techniques

# Attachments, connecting and disconnecting 239

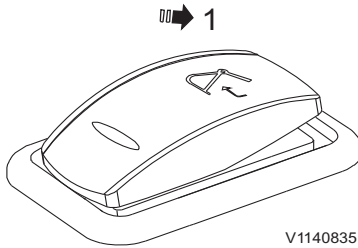

V1140835

Attachment quick coupler switch, left

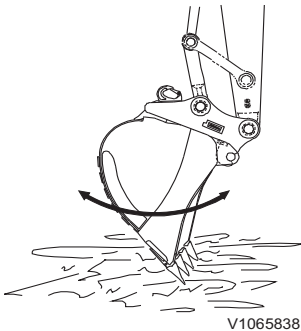

V1065838

11 Press the left attachment quick coupler switch for more than 0.7 seconds to confirm that the attachment quick coupler is locked. Then the buzzer sound will be turned off and the check message and indicator will disappear. See page 35 for more information.

- 12 Do the following tests to check that the attachment quick coupler is fastened securely.
- Press the bucket against the ground. In this position, curl the bucket in and out to check that it is locked in the correct position.
  - If you are uncertain about whether the bucket is securely locked to the attachment quick coupler, get out and check that the front lock device is fully engaged.
  - Do not use the machine if the attachment quick coupler is not working.
  - Contact a workshop authorized by Volvo if anything is wrong.

### **WARNING**

Risk of crushing.

If the red warning lamp for open attachment bracket lights up while working, the attachment could fall off and cause serious crushing injury or death.

**Stop working with the machine immediately and make sure the attachment bracket is properly locked before starting to work again.**

240 Operating techniques  
Buckets

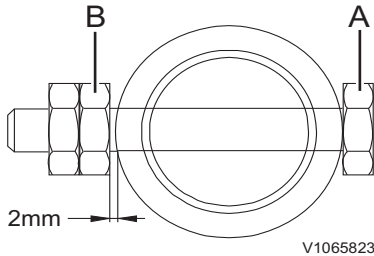

## Buckets

### Bucket, changing Bucket, removal

#### **WARNING**

Risk of splinter injury.

Striking the bucket pin with a hammer could cause metal chips to fly around and cause serious splinter injury.

**Always wear face and eye protection, hard hat and gloves while removing and installing the bucket pins.**

- 1 Lower the bucket lightly on the ground.
- 2 Remove the lock screw (A) and nut (B) of each pins.
- 3 Remove pins (C and D) and O-rings (E), then remove the bucket.

#### **NOTICE**

**Block the removed bucket to stabilise it. Keep the pins clean and do not damage the O-ring.**

### Bucket, Installation

#### **CAUTION**

Risk of cutting and crushing.

Loose parts could cause crushing and cutting injury.

**Never use your fingers for checking alignment between loose parts. Always use a tool.**

- 1 Align the dipper arm and links to the bucket.
- 2 Put O-rings (E) at the holes for the dipper arm and link. Align the holes between bucket and dipper arm and links.
- 3 Apply grease to the holes.
- 4 Insert pins (C and D).
- 5 Install lock screw (A) and nut (B) of each pins.

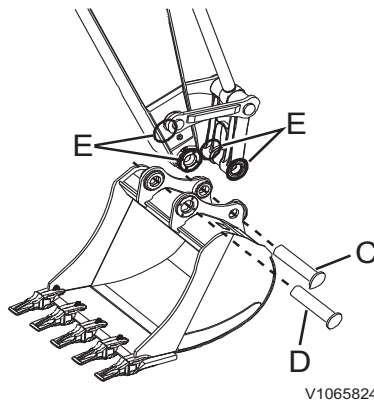

#### **NOTICE**

**Make sure that there is a clearance of at least 2 mm (0.08 in) between nut and pin boss. Lubricate the pin.**

## Working with buckets

### NOTICE

Select a suitable attachment that fits the machine on which it is to be installed. The types of attachments that can be installed vary with the machine type. Contact a workshop authorised by Volvo.

The machine is prepared for several different type of optional equipment to perform many types of work. Only the simplest operations are described below.

### Backhoe work

Backhoe work is digging the material at a lower level than the machine is located.

When the angle between bucket cylinder and links, dipper arm cylinder and dipper arm is set to  $90^\circ$  respectively, the working efficiency of each cylinder will be at its maximum. Take advantage of this angle to improve the work efficiency. The range for effective digging is when the dipper arm is between  $30^\circ$  forward and  $45^\circ$  rearward. There may be a little difference according to digging depth. Do not use the cylinder up to its stroke end, but only within this range.

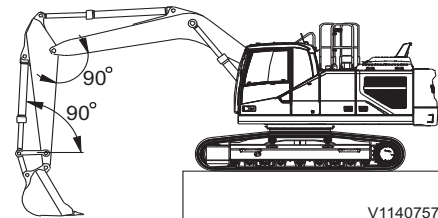

V1140757

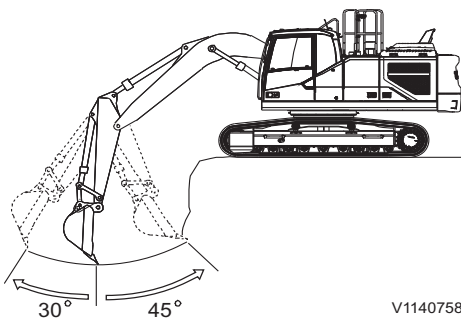

V1140758

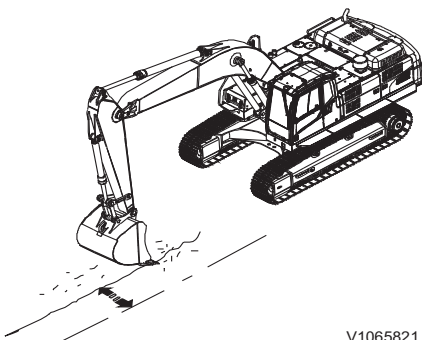

V1065821

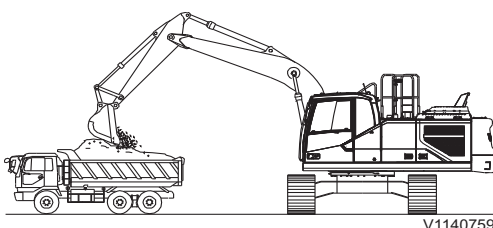

V1140759

### Ditching work

Install a proper bucket for ditching. Place the machine where the ditching is performed effectively.

In case of a wide ditch, dig both sides in first, and then dig the center area.

### Loading work

Position the hauler or truck so as to achieve a small swing movement and good visibility for the operator to work effectively.

Also load over the rear side of the dump truck rather than over the side, as this makes the operator work easier and increases efficiency.

## Hammer

### Hammer (hydraulic breaker)

Select the proper attachment in accordance with the machine on which the attachment is installed. The type of attachment which is able to be installed varies with the machine type.

Use only hydraulic breaker that is recommended by Volvo. Contact an authorized Volvo dealer workshop.

#### NOTE!

For complete instructions for the hydraulic breaker, read the separate Operator's Manual for the hammer.

Do not operate the hydraulic breaker until you read and understand both machine and hydraulic breaker manuals.

#### NOTE!

Lubricate the excavator units (such as boom, arm and linkages) twice a day.

If the machine is provided with an attachment quick coupler, this must be checked every day at the same time as rectifying any play.

### WARNING

Risk of severe personal injury.

While working with the hammer flying chips of rock could cause severe injury.

**Provide protective nets for the windscreens. Keep windows and door closed and prevent persons from entering the risk zone when operating the hydraulic breaker.**

### Main works

#### NOTE!

The machine images in this section are one of excavator's images. However the guideline is valid for all excavators.

- Breaking stone
- Demolition work
- Road repairing

It is widely used for demolition of buildings, breaking road surfaces, tunneling work, smashing slag, and breaking or cutting stone.

Press the tool (chisel) firmly onto the surface at a right angle as shown.

#### NOTE!

The standard hydraulic breaker must not be used under water. If the water fills the space where the piston strikes the tool, a strong pressure wave is generated and the hydraulic breaker may be damaged.

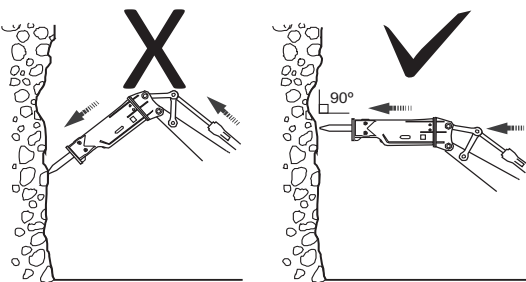
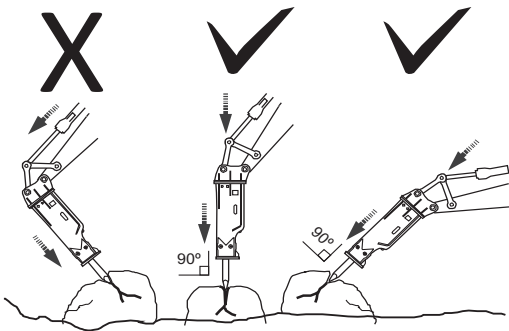

V1111448

## 244 Operating techniques Hammer

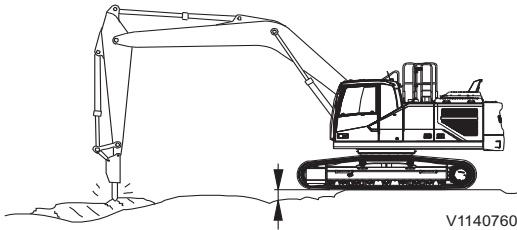

When striking, press the tool firmly onto the surface, and lift the frame about 5cm. Never raise the machine unnecessarily high.

### NOTE!

When operating the breaker, track motors should be located at rear position to prevent motors damage.

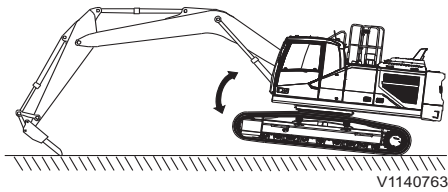

Do not raise the machine by extending the bucket cylinder to maximum.

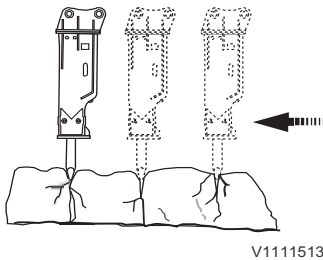

If the surface is repeatedly struck but it is not broken within 30 seconds, move the hydraulic breaker to break from the end portion.

Also If the block has not cracked after a series of approx. ten strokes, change the point of attack.

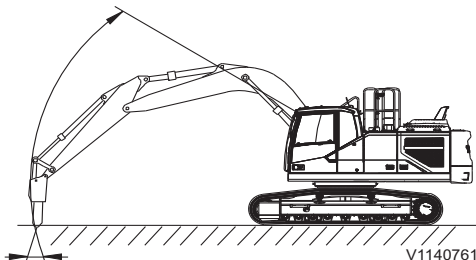

The striking direction of tool and hydraulic breaker body are slightly deviated. Therefore, adjust the bucket cylinder so that the direction of body and tool is always the same.



Operating techniques  
**Hammer** 245

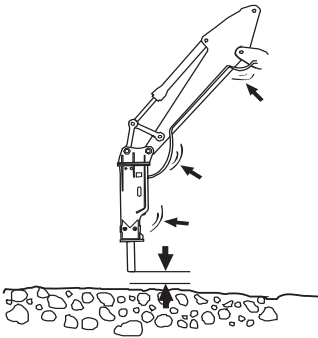

V1111449

Listen to the sound of the hydraulic breaker when you are using it. If the sound becomes weaker and the impact less efficient, the tool is misaligned with the material and/or there is not enough feed force on the tool. Realign the tool and press the tool firmly against the material.

Stop operation if hydraulic hoses shaking abnormally. Immediately stop the operation.

Otherwise this may result in serious failure in the hydraulic system including pumps. Check gas pressure of back head and accumulator and charge the pressure to recommended value. See the breaker manual for detail.

Do not operate the bucket, arm and boom cylinders to their end positions than 10 cm (4 in) to prevent cylinder's damage.

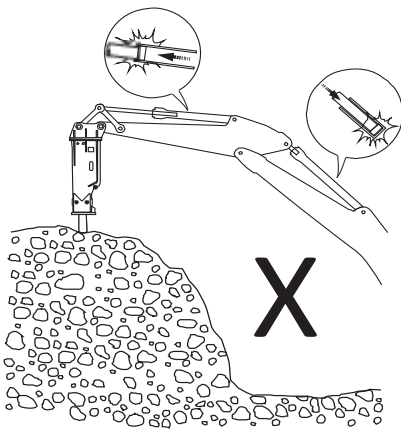

V1148361





Operating techniques  
**Hammer** 247

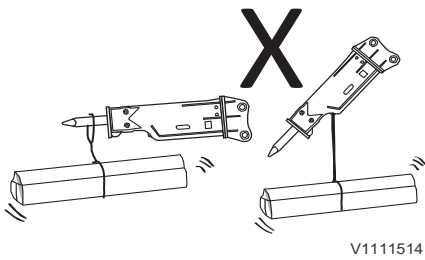

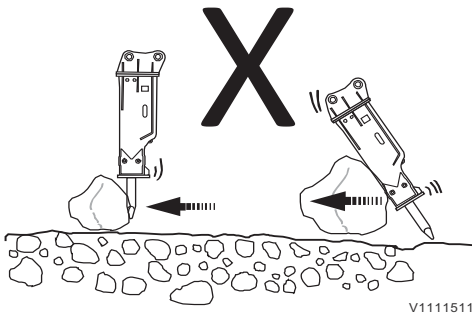

The hydraulic breaker is not designed to lift or transport loads. The hydraulic breaker may easily be damaged and it is very dangerous.

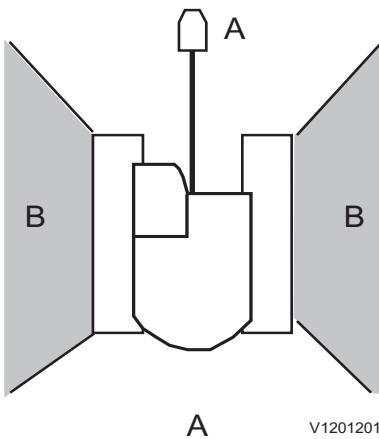

Avoid moving and gathering the objects using hydraulic breaker.



The best working area is in the longitudinal direction of the undercarriage and within an approximate 45° sector in both directions (A). Do not operate the hydraulic breaker at (B) area. The machine can be unstable and undercarriage component may be failure as a result from excessive loads on the undercarriage.

- A  Longitudinal direction of the undercarriage
- B  Across undercarriage: not recommended

## Working with long range attachments

### **NOTICE**

With certain attachment combinations there is a risk that the attachment may strike the cab. Avoid damage by being careful when working close to the machine.

### **NOTICE**

Only attachments approved for the machine by Volvo may be used.

Long range attachments can be used in clearing and dredging lump of clay accumulated in the river and reminders of waste water effectively.

- Do not use long-range attachment in general excavating, because it is designed for excavating small amounts.
- Operate the machine smoothly in order to keep stability and safety when travelling.
- Do not stop the machine abruptly, which may cause heavy joggling of the attachment. It also causes excessive force to the attachments which finally may damage the machine.
- Never use power boost switch with long reach boom and arm.
- Boom, dipper arm and bucket have big inertial power compared to standard equipments. Therefore, do not operate the machine at the ends of stroke of each cylinder.
- Do not travel the machine or raise the main body with the bucket grounded. It may give excessive force to pin around the bucket.

## Hose rupture valves

(Optional equipment)

### NOTICE

Do not dismantle the hose rupture valve as it is pressurised. Contact a workshop authorised by Volvo if problems arise.

### WARNING

Risk of serious injury.

Working under an attachment that is not properly supported could cause serious injury.

**Before working under an attachment, ensure the attachment is properly supported and the control lockout lever has been locked and the engine is shut off. Ensure that nobody enters the cab while working under the attachment.**

### Attachment lowering after hose rupture

#### When engine is running

Lower the boom or dipper arm with the operating levers in the usual way. Collect the oil from the ruptured hose in a suitable vessel.

#### When engine is stopped

The servo hydraulic pressure is maintained by a pressure in accumulator for a few minutes, which permits the operator to lower the boom or dipper arm in the usual way with operating levers. Do not wait too long to lower the boom, the servo hydraulic pressure will reduce at a speed depending on your machine's condition and equipment. Collect the oil from the ruptured hose in a suitable vessel.

250 Operating techniques  
Hose rupture valves

When engine is stopped and with no servo hydraulic pressure

**WARNING**

Risk of high pressure injection.  
The hydraulic oil is under high pressure.  
Discharging hydraulic oil will cause serious injury when injected into the skin.

**Depressurize the hydraulic system before connecting or disconnecting hydraulic hoses.**

**NOTICE**

Always use personal protective equipment, such as working gloves, overalls and face protection or protective goggles with side protection before you release excess pressure in a hydraulic hose or pipe connection.

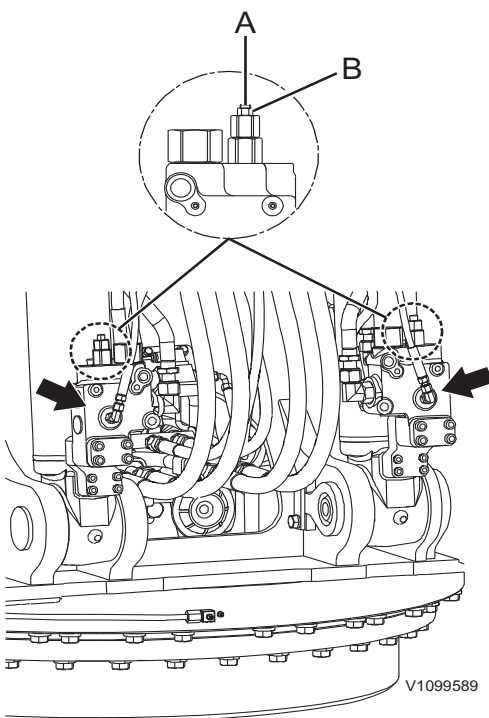

Hose rupture valves  
A Adjusting screw  
B Lock nut

- 1 Loosen lock nut (B) and turn adjusting screw (A) counter-clockwise slowly.  
**Before turning the adjusting screw, mark its position to facilitate assembling later (setting pressure: 37.8 MPa, 385 kgf cm<sup>2</sup>, 5482 psi)**  
The boom will then slowly be lowered to the ground.
- 2 Turn adjusting screw (A) to its original position.
- 3 Hold adjusting screw (A) securely and tighten lock nut (B).
- 4 Contact an authorized Volvo Construction Equipment dealer workshop.



## Selecting track shoes

Grouser	Use	Precautions when using
A 500 mm 600 mm	Rocky ground, normal soil	Travel in low speed when travelling on rough ground with obstacles such as large boulders and fallen trees.
B 700 mm 800 mm	Soft ground	Travel in high speed only on flat ground. When it is impossible to avoid travelling over obstacles, lower the travel speed to approximately half of low speed. <b>NOTE!</b> Cannot be used on rough ground where there are large obstacles such as boulders or fallen trees.
C 900 mm	Extremely soft ground (boggy ground)	Use only for ground where "A" and "B" are impossible to use. Travel in high speed only on flat ground. When it is impossible to avoid travelling over obstacles, lower the travel speed to approximately half of low speed. <b>NOTE!</b> Cannot be used on rough ground where there are large obstacles such as boulders or fallen trees.

## Lifting objects

There may be local and/or national regulations that govern the use of machines which apply for lifting operations. Obey the local and/or national regulations. Contact your local Volvo dealer for more information.

If the machine is used to lift objects within an area that is governed by the European Machinery Directive 2006/42/EC and its amendments, the machine must be equipped with following working devices.

- A load hooking device.
- A hose rupture valve on the boom or in some countries hose rupture valve on both boom and dipper arm is required depending on risk assessment. See page 249.
- A overloading warning device. See page 79.

Safe lifting make great demands on the operator. Read the below recommended steps before starting any lifting.

- Use qualified and properly trained operators who have:
  - Specific machine knowledge and training.
  - Read and understand the operator's manual and its load charts. See page 439.
  - Specific machine knowledge and training how to properly rig the load.
  - Full responsibility for all aspects of the lift.
- Interrupt the lift if not fully confident of a safe lift.
- Select machine with sufficient capacity for the total expected load, reach and swing. Ideally, load should be less than the load listed on the load chart at maximum reach across the undercarriage. See page 439.
  - Know the mass (weight) of the item to be lifted.
  - Know the start and finish positions, load lifting position and setting position.
  - Know the machine configuration, especially the dipper arm and boom lengths and counterweight mass.
  - Choose the correct lifting chart taking into account all attachments and rigging materials that will be used during the lift. The weight of the rigging materials and attachments, should be deducted from the load capacity.
- Warm up the machine to normal working temperatures.



- Position the machine on firm level ground.
- Properly set outriggers and blade when applicable.
- Visually inspect the rigging materials for defects, cracks, or any other damage before lifting objects.
- Once the load is properly rigged, ensure all ground workers are clear of the load and the machine. If guiding of the load is necessary, use ropes or other type of slings tied to the load to keep ground workers at a safe distance.
- Use a trained signalman to direct all aspects of the move.

### **NOTICE**

**It is the responsibility of the owner or the operator to know and follow the local or national regulations that apply for lifting operations. For further information, contact your dealer.**

Keep the following in mind to ensure the highest level of controllability and safety when lifting.

- Operate on solid, flat, level ground.
- If ground conditions are unstable, for example loose gravel, sand or water, do not work with loads close to the rated load maximums given on the machine load chart.
- Do not swing the excavator abruptly with a suspended load, the effects of centrifugal force will impair machine stability.
- Do not use the swing or dipper arm-in operation to drag a load.
- Do not operate the machine while someone is hanging on or in the bucket or attachments.



254 Operating techniques  
Lifting objects

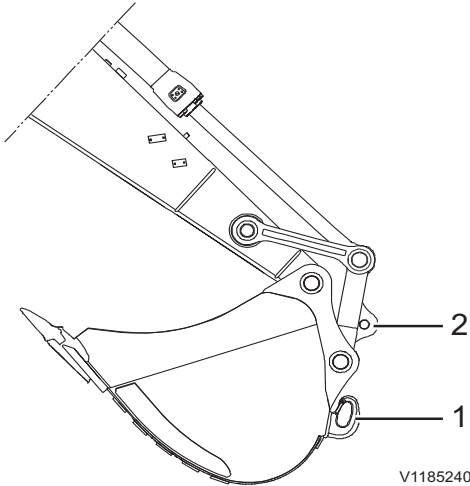

- 1 Lifting device on bucket
- 2 Lifting device on connecting rod

**1 Load hooking device on bucket or attachment quick coupler**

The lifting device whether mounted on a bucket or other attachment must not be subjected to lateral loads. The load must be applied longitudinally to the hook.

Always ensure that the load lies within the marked permissible lifting load of lifting device when manoeuvring the dipper arm and bucket.

Exceeding these limits can cause serious injury.

Remember that the operator is responsible in case of an accident.

**NOTE!**

Lifting capacity of hook on the bucket or attachment quick coupler could be lower than the machine's lifting capacity.

Visually check that the max. lifting capacity of hook marked on the bucket or attachment quick coupler. If the marking for lifting capacity on the bucket or attachment quick coupler is worn out, contact an authorized Volvo dealer for the information.

**NOTE!**

This represents the capacity of the hook and not the rated load capacity of the machine which varies according to ground conditions, reach, travel position and so on.

**NOTE!**

Only use lifting device recommended by Volvo in order to avoid damage to the machine. Contact your dealer for information regarding other lifting device.

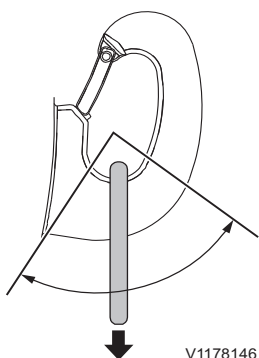

Permissible working range of lifting hook

**! WARNING**

Risk of crushing.

A lifting hook loaded outside the permissible working range could cause the load to fall off and lead to serious crushing injury or death.

**Never load the lifting hook outside the permissible working range.**

**NOTE!**

Bear in mind that the lifting capacity of the machine is greater when the attachment is pulled in closer to the machine.



Lifting equipment and lifting hook must be clean and in a serviceable condition. Before lifting, check that the lifting device is correctly secured.

### **WARNING**

Risk of fatal accidents.

A suspended load could drop if the hydraulic system fails and cause fatal accidents and serious injury or death.

**Never leave the machine with a suspended load.**

## **2 Load hooking device on connecting rod**

Lifting device on connecting rod is designed to lift the marked permissible load on the lifting device. Consider also the lifting capacity of your machine, see page 439.

## Overload warning

### NOTICE

The overload warning does not give the actual machine limit, but constitutes an indication of a potential risk of tipping over in case of deteriorating stability.

The overload warning is engaged and disengaged using the button on the machine control keypad, see page 79.

### NOTICE

The overload warning must always be engaged when lifting a suspended load.

When an overload is registered, the central warning lamp and the control lamp illuminate on the IC (Instrument Cluster) and the buzzer sounds. When digging, the overload warning should be disengaged.



V1065467

Overload warning (Red)

## Overload warning pressure

Default pressure of the overload warning system is 210 bar (3046 psi).

### NOTE!

Overload warning pressure must be below the rated lifting capacity in accordance with European Machinery Directive 2006/42/EC, local and/or national government regulations. Contact your local Volvo dealer for more information.

If the default pressure needs to be adjusted in accordance with local and/or national government regulations, contact a qualified service technician.

### ! WARNING

Risk of accidents.

Overloading could lead to a turnover of the machine or to falling load and attachments.

**Do not exceed the machine's maximum lifting capacity and never ignore the overload warning.**

Lifting capacities are based on the machines with following conditions:

- Lifting point: At the dipper arm end, without bucket



- Operator and all fluids (e.g., all the lubricants and fuel in the fuel tank are fully topped up.)
- Dozer blade/stabiliser is up (if equipped).

The values in the lifting capacities are in compliance with ISO10567. Rated loads do not exceed 87% of hydraulic lifting capacity or 75% of tipping load. See page 439 for more information.

### Overload warning system, checking

#### NOTE!

A check of the overload warning equipment must be carried out every 1000 hours, see page 310.

## Signalling diagram

**Manual signalling to operator of a mobile excavator as per SAE J1307.**

The primary use of hand signals is for a signalman to direct the lifting, handling, and placement of loads attached to working equipment. Hand signal usage may also be applicable to earthmoving operations and/or machine travel when the operator's visibility is obstructed.

If a rapid lifting, lowering or moving movement is required, the dipper arm movements should be carried out more lively. If two different machines are used for lifting the same load, there should be an agreement beforehand how the lift should be carried out and what signals should be given to the respective operators.

<p>V1065920</p>	<p>V1065921</p>	<p>V1065923</p>
<p><b>RAISE LOAD VERTICALLY</b> With either forearm vertical, forefinger pointing up, move hand in small horizontal circles.</p>	<p><b>LOWER LOAD VERTICALLY</b> With either arm extended downward, forefinger pointing down, move hand in small horizontal circles.</p>	<p><b>MOVE LOAD IN HORIZONTALLY</b> With either arm extended, hand raised and open toward direction of movement, move hand in direction of required movement.</p>
<p>V1065924</p>	<p>V1065925</p>	<p>V1065926</p>
<p><b>MOVE LOAD OUT HORIZONTALLY</b> With either arm extended, hand raised and open toward direction of movement, move hand in direction of required movement.</p>	<p><b>RAISE BOOM</b> With either arm extended horizontally, fingers closed, point thumb upward.</p>	<p><b>LOWER BOOM</b> With either arm extended horizontally, fingers closed, point thumb downward.</p>
<p>V1065927</p>	<p>V1065928</p>	<p>V1065929</p>



Operating techniques  
Signalling diagram 259

<p><b>SWING</b> With either arm extended horizontally, point with forefinger to direction of swing rotation.</p>	<p><b>DIPPER ARM INWARD</b> With both hands clenched, point thumbs inward.</p>	
<p>V1065930</p>	<p>V1065931</p>	
<p><b>DIPPER ARM OUTWARD</b> With both hands clenched, point thumbs outward.</p>	<p><b>CLOSE BUCKET</b> Hold one hand closed and stationary. Rotate other hand in small vertical circle with forefinger pointing horizontally at closed hand.</p>	<p><b>OPEN BUCKET</b> Hold one hand open and stationary. Rotate other hand in small vertical circle with forefinger pointing horizontally at open hand.</p>
<p>V1065933</p>	<p>V1065934</p>	<p>V1065935</p>
<p><b>TURN THIS FAR TO GO</b> Raise forearm with closed fist indicating inside of turn. Move other fist in vertical circle indicating direction of track or wheel rotation.</p>	<p><b>THIS FAR TO GO</b> With hands raised and open inward, move hands laterally, indicating distance to go.</p>	
<p>V1065936</p>	<p>V1065937</p>	<p>V1065938</p>
<p><b>COUNTER ROTATE</b> Place hand on head indicating side or reverse track or wheel rotation. Move other hand in vertical circle indicating forward rotation of other track or wheel.</p>	<p><b>MOVE SLOWLY</b> Place one hand motionless in front of hand giving motion signal. Raise load slowly is shown.</p>	
<p>V1065939</p>	<p>V1065940</p>	<p>V1065941</p>



260 Operating techniques  
Signalling diagram

<p><b>TRAVEL</b> Raise forearm with closed fist indicating inside of turn. Move other fist in vertical circle indicating direction of track or wheel rotation.</p>		<p><b>STOP</b> With either arm extended laterally, hand open downward, move arm back and forth.</p>
<p>V1065942</p>	<p>V1065922</p>	
<p><b>EMERGENCY STOP</b> With both arms extended laterally, hands open downward, wave arms back and forth.</p>	<p><b>STOP ENGINE</b> Draw thumb or forefinger across throat.</p>	



---

## Safety when servicing

This section deals with the safety rules which should be followed when checking and servicing the machine. It also describes the risks when working with unhealthy material and ways to avoid personal injuries.

Further safety rules and warnings texts are given within the respective sections.

### WARNING

Risk of burns!

Hot machine parts could cause burns.

**Allow hot machine parts to cool before performing adjustments or service. Wear personal protective equipment.**



## Service position

### NOTE!

Before beginning any service work, the following measures must first be taken.

- 1 Position the machine on even, firm and level ground.
- 2 Put the attachment on the ground.
- 3 Turn off the engine. After releasing the system and tank pressure, remove the ignition switch. See page 337.
- 4 Make sure the control lockout lever is down to lock the system securely, see page 109.
- 5 Pressurized lines and vessels should have the pressure released gradually to avoid risks.
- 6 Allow the machine to cool.

A suitable position is stated in the description for the different service operations. If no particular position is stated, the machine should be parked in service position A.

### Service position A

Retract the bucket and dipper arm cylinder completely, and then lower the boom on the ground.

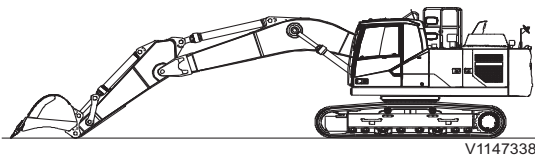

V1147338

### Service position B

Extend the bucket cylinder completely, retract the dipper arm cylinder completely and lower the boom on the ground.

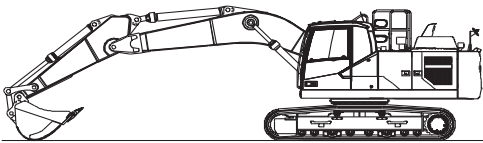

V1147339

## Before service, read

### Preventing personal injury

- Read the Operator's Manual before the service work is started. It is also important to read and follow information and instructions on plates and decals.
- Do not wear loose-fitting clothing or jewellery, which can get caught and cause injury.
- Always wear a hard hat, protective goggles, gloves, protective shoes and other protective articles when the work so requires.
- Make sure that the ventilation is sufficient when starting the engine indoors.
- Do not stand in front of or behind the machine when the engine is running.
- If service work has to be carried out under raised lifting arms, these must first be secured. (Engage the control lever lockout and apply the parking brake if the machine is equipped with one).
- Turn off the engine before opening the rear door and engine cover.
- When the engine is stopped, there is a remaining accumulated pressure in the pressurized systems. If a system is opened without having first released the pressure, liquid under high pressure will jet out.
- When checking for leaks, use paper or hardboard, not your hand.
- Make sure that stepping surfaces, handholds and anti-slip surfaces are free from oil, diesel fuel, dirt and ice. Never step on parts of the machine that are not intended for this.
- It is important to use correct tools and equipment. Broken tools or equipment should be repaired or changed.

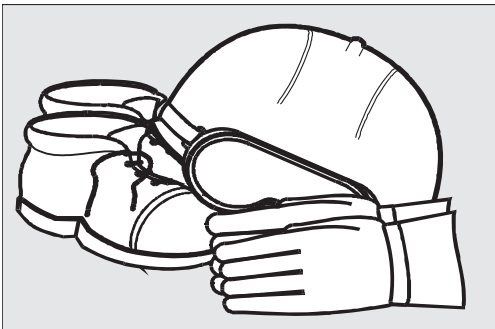

V1065951



### Preventing machine damage

- When lifting or supporting the machine or parts of the machine, use equipment with a sufficient lifting capacity.
- Lifting devices, tools, working methods, lubricants and parts prescribed in the Operator's Manual should be used. Volvo Construction Equipment will not accept any responsibility otherwise.
- Make sure that no tools or other objects, which may cause damage, have been forgotten in or on the machine.
- Release the pressure in the hydraulic system before starting the service work.
- Never set a relief valve to a higher pressure than that recommended by the manufacturer.
- Machines, which are used within a polluted or in another way insanitary area should be equipped for this kind of work. Special safety regulations apply when servicing such a machine.
- When installing two-way radio, mobile telephone or similar equipment, the installation should be carried out in accordance with the manufacturer's instructions in order to eliminate interference with the electronic system and components intended for the function of the machine, see page 22.
- Measures to be taken in connection with electric welding, see page 322.
- Make sure that all covers on the machine are in position before the engine is started and the machine is put to work.



### Preventing environmental influence

Be conscious of the environment when carrying out service and maintenance. Oil and other liquids dangerous to the environment and released into the environment will cause damage. Oil degrades very slowly in water and sediment. One litre of oil can destroy millions of litres of drinking water.

#### NOTE!

In common for all points below is that all waste is to be handed over to a treatment and disposal firm approved by the authorities.

- When draining, oils and liquids must be collected in suitable vessels and steps taken to avoid spillage.
- Used filters must be drained of all liquid before they are passed on as waste. Used filters from machines which work in environments with asbestos or other dangerous dust, must be placed in the bag supplied with the new filter.
- Batteries contain substances dangerous to the environment and health. Used batteries must therefore be handled as waste dangerous to the environment.
- Consumables, for example used rags, gloves and bottles may also be contaminated with oils and liquids dangerous to the environment and must in that case be treated as waste dangerous to the environment.

266 Safety when servicing  
Before service, read

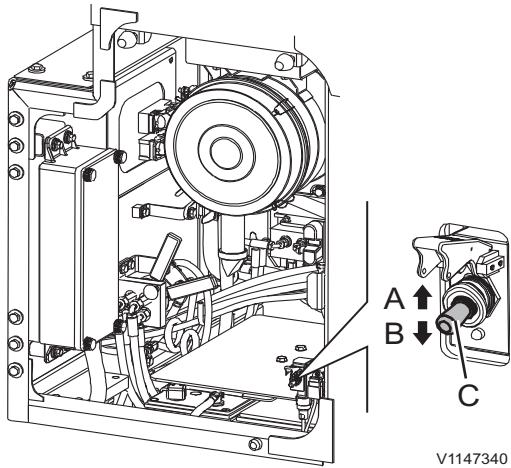

- A ON position
- B OFF position
- C Battery disconnect switch

V1147340

## Battery disconnect switch

### NOTICE

Do not turn off the battery disconnect switch when the engine is running. The electrical system may be damaged.

Battery disconnect switch (C) is located inside the left side door of the machine. When welding, servicing of electrical system or after finishing work of the day for safety, the battery disconnect switch should be turned off.

### NOTE!

Make sure that the indicator light goes out after turning off the battery disconnect switch. This may take a couple of minutes depending on the system status at the time.

## Electrical distribution box

Relays and fuses are in the electrical distribution box which is located on the rear side of cab.

### NOTICE

Never install a fuse with a higher amperage than what is stated on the decal. Risk of damage or fire on the circuit board.

Relays and fuses are easily accessible after discovering the cover of box. A decal which shows the exact positions and specifications of respective relays and fuses is provided on the inside of cover, see page 362.

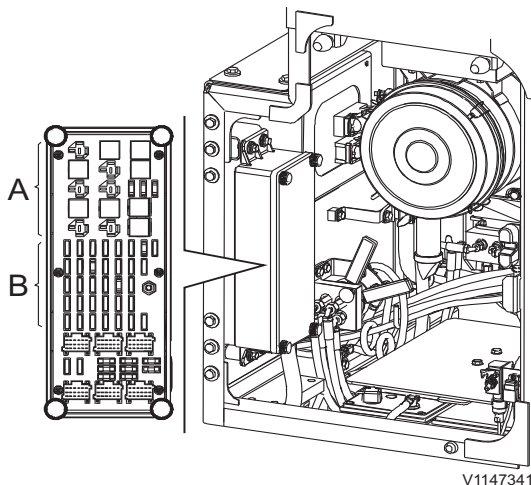

Electrical distribution box

- A Relays
- B Fuses

V1147341

### NOTE!

If a fuse blows repeatedly in the same position, the cause of the fault has to be investigated.



## Hydraulic system

### **NOTICE**

Any work on the hydraulic system requires great demands on cleanliness. Even very small particles can cause damage or clog up the system.

Therefore, wipe areas in question clean before any work is carried out.

The complete hydraulic system including the pressure-limiting valves is set to the correct values from factory.

For any work on the hydraulic system and on pressure-limiting valves the values and tolerances from the Volvo service manual must be applied, otherwise the guarantee from the manufacturer will be void.

Only a qualified service technician is allowed to work on the hydraulic system.



## Hydraulic oil

### NOTE!

Hydraulic oil is hazardous to the environment. Immediately use barriers to contain spilled oil and follow local regulations concerning hazardous materials.

### **NOTICE**

Only hydraulic oil that is approved by Volvo may be used.

### **NOTICE**

Use the same hydraulic oil that is already in the system. The hydraulic system may be damaged if different brands of hydraulic oil are mixed.

### Hydraulic bio oil

- 1 When changing from a mineral oil to a bio oil, the oil must be drained as much as possible and it is required to flush the hydraulic system.
- 2 For the drain points and changing method, please contact the workshop authorized by Volvo Construction Equipment.

## Entering, leaving and climbing the machine

### Entering, leaving and climbing the machine

#### **NOTICE**

The safety regulations and operating instructions issued by the manufacturer must be strictly observed.

- Do not jump on/off a machine, especially never get on / off when the machine moves.
- Never grasp the control lever to get on / off.
- Use handholds and steps when entering, leaving or climbing the machine.
- Use the three-point grip, that is two hands and one foot or two feet and one hand.
- Always face the machine.
- Always wipe mud and oil off all footboards, handrails and your footwear, especially clean the windows, rear view mirrors and lights.
- Clean your boots and wipe your hands before getting on the machine.
- Do not use hand grip (A) of the cab door as a support when entering, leaving and climbing the machine. it is not strong enough to be used as a support. it should only be used for closing the door.

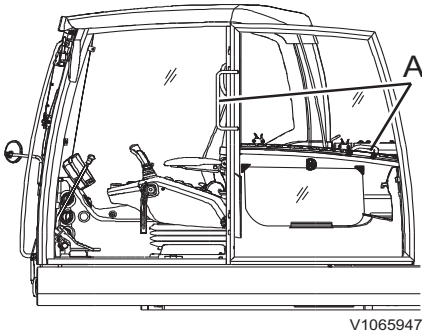

V1065947



V1065948





## Fire prevention

### NOTE!

Using the machine in environments with high risk of fire or explosion requires special training and equipment.

There is always a risk of fire. Find out what kind of fire extinguisher is used on your working site and how to use it. If the machine is equipped with a fire extinguisher, it should be kept inside the cab on the left side of the operator.

If the machine is to be provided with a hand-held fire extinguisher, it should be of the ABE type (ABC in North America). The designation ABE means that it is possible to extinguish fires in both solid organic material and liquids, and that the fire extinguishing compound does not conduct electricity. Efficiency class I means that the effective operating time of the extinguisher must not be less than 8 seconds, class II at least 11 seconds and grade III at least 15 seconds.

A hand-held fire extinguisher ABE I normally corresponds to a powder content of 4 kg (8.8 lb) (EN-grade 13A89BC), standard EN 3-1995, parts 1, 2, 4 and 5.

### Fire prevention measures

- Do not smoke or have an open flame near a machine when filling with fuel or when the fuel system is opened and in contact with the surrounding air.
- Diesel fuel oil is flammable and must not be used for cleaning. Use conventional car care products meant for cleaning or degreasing. Also bear in mind that certain solvents can cause skin rashes, damage to the paint finish and constitute fire hazard.



## Safety when servicing Fire prevention 271

- Keep the place clean where the service is to be carried out. Oil and water can make the floor slippery and is also dangerous in connection with electrical equipment or electrically powered tools. Oily and greasy clothes are a serious fire hazard.
- Check daily that the machine and the equipment, for example underbelly plates are free from dust and oil. Besides reducing the risk of fire, it is also easier to detect faulty or loose components.

### NOTE!

Take great care if a high-pressure wash is used for cleaning. Electrical components and electrical leads can be damaged even at a moderately high pressure and temperature. Protect electrical leads in an appropriate way.

- Take extra care when cleaning a machine working in a fire-sensitive environment, for example saw-mill and refuse dumps. The risk of spontaneous combustion can be further reduced by installing insulation of the silencer guard.
- It is important that the fire extinguisher is maintained in order to work when it is needed.
- Check that fuel lines, hydraulic and brake hoses and electrical cables have not been damaged by chafing or are not in danger of being damaged in that way because of incorrect installation or clamping. This applies particularly to unfused cables, which are red and marked R (B+) and routed:
  - between the batteries
  - between battery and starter motor
  - between alternator and starter motor

Electrical cables must not lie directly against oil or fuel lines.
- Do not weld or grind on components which are filled with flammable liquids, for example tanks and hydraulic pipes. Exercise care with such work also in the proximity of such places. A fire extinguisher should be kept near to hand.



### **Actions in case of fire**

**If the circumstances permit and your own safety is not jeopardised, take the following steps at the slightest sign of fire:**

- 1 Stop the machine, if the machine is in motion.
- 2 Lower attachments to the ground.
- 3 Move the control lockout lever to locked position, if so equipped.
- 4 Turn the ignition switch to stop position.
- 5 Exit the cab.
- 6 Call the fire brigade.
- 7 If possible to access safely, turn off the battery disconnect switch or emergency stop switch.
- 8 Attempt to put out the fire, if possible. Otherwise, move away from the machine and out of the danger zone.

### **Actions after fire**

**When handling a machine which has been damaged by fire or been exposed to intense heat, the following protective measures must be followed:**

- Use thick, protective gloves made of rubber and wear goggles.
- Never touch burnt components with your bare hands in order to avoid contact with melted polymer materials. First wash thoroughly with plenty of lime water (a solution consisting of calcium hydroxide, that is slaked lime in water).
- Handling heated fluoro-carbon rubber, see page 273.

## Handling hazardous materials

### Heated paint

#### **WARNING**

Risk of toxin inhalation.

Burning of painted, plastic or rubber parts produces gases that could damage respiratory tracts.

**Never burn painted or rubber parts or any plastics.**

Heated paint gives off poisonous gases. Therefore, paint must be removed from an area with a radius of at least 10 cm (4 in) before carrying out welding, grinding or gas cutting. In addition to the health hazard, the weld will be of inferior quality and strength, which, in the future, may cause the weld to break.

#### **Methods and precautionary measures when removing paint**

- **Blasting**
  - use respiratory protective equipment and protective goggles
- **Paint remover or other chemicals**
  - use a portable air extractor, respiratory protective equipment and protective gloves
- **Grinding machine**
  - use a portable air extractor, respiratory protective equipment and protective gloves and goggles

Never burn painted parts after they have been discarded. They should be disposed of by a licensed disposal plant.

#### **Heated rubber and plastics**

Polymer materials can, when heated, form compounds which are dangerous to health and environment and must therefore never be burned when scrapped.

**If gas cutting or welding is to be carried out near such materials, the following safety instructions must be followed:**

- Protect the material from heat.
- Use protective gloves, protective goggles and respiratory protective equipment.

### Heated fluoro-carbon rubber

#### **WARNING**

Risk of serious injury.

At very high temperatures fluoro-carbon rubber forms substances which are very corrosive to skin and lungs.

**Always wear personal protective equipment.**

**When handling a machine which has been damaged by fire or been exposed to intense heat, the following measures should be taken:**

- Use thick, rubber gloves and wear protective goggles.
- Discard gloves, rags and other items that have been in contact with heated fluoro-carbon rubber after first having washed these items in lime water (a solution of calcium hydroxide, that is slaked lime in water).
- The area around a part which has been very hot and which may be made of fluoro-carbon rubber should be decontaminated by thorough and ample washing with lime water.
- As a precaution, all seals (O-rings and other oil seals) should be handled as if they were made of fluoro-carbon rubber.
- The hydrofluoric acid may remain on the machine parts for several years after a fire.
- If swelling, redness or a stinging feeling appears and one suspects that the cause may be contact with heated fluoro-carbon rubber, contact a medical doctor immediately. Several hours may pass, however, before any symptoms appear and there is no immediate warning.
- The acid cannot be rinsed or washed off from the skin. Treat instead with Hydrofluoric Acid Burn Jelly or similar before contacting a medical doctor.

### Crystalline silica (quartz) dust

#### **WARNING**

Risk of hazardous inhalation.

Working in environments containing dangerous dust can lead to serious health problems.

**Wear personal protective equipment when working in dusty environments.**

Crystalline silica is a basis component of sand and granite. Therefore, many activities at construction and mining sites, such as trenching, sawing and boring, produce crystalline silica dust. This dust can cause silicosis.

The employer or working site management should provide the operator with information about the presence of crystalline silica in the work site along with specific work instructions and precautions and also necessary personnel protection equipment. Also check the local / national regulations regarding silica / silicosis.

## Batteries

### **WARNING**

Risk of chemical burns.

The battery electrolyte contains corrosive sulphuric acid which could cause severe chemical burns.

**If electrolyte spilled on your bare skin, remove it immediately and wash the affected area with soap and plenty of water. If it gets into your eyes or any other sensitive body part, rinse with plenty of water and seek immediate medical attention.**

- Do not smoke near batteries as these give off explosive gases.
- Make sure that metal objects, for example tools, rings and watch straps, do not come into contact with the battery pole studs.
- Make sure the protections are always installed over the battery pole studs.
- Do not tilt a battery in any direction. Battery electrolyte may leak out.
- Do not connect a discharged battery in series with a fully charged battery. Risk for explosion.
- When removing a battery, disconnect the ground cable first and when installing, connect the ground cable last in order to reduce the risk of sparks.
- Discarded batteries must be taken care of according to national environmental requirements.
- Charging batteries, see page 321.
- Starting with booster batteries, see page 175.



## Refrigerant

### Environmental precautions

The air conditioning system of the machine is filled with R134a refrigerant at the factory. R134a refrigerant is a fluorinated greenhouse gas and contributes to global warming.

Do not release refrigerant into the environment. See page 366 for the amount of R134a refrigerant in your machine and its global warming potential.

### Safety precautions

Work on the air conditioning system must only be performed by a qualified service technician. Do not attempt to perform work on the air conditioning system.

Wear safety goggles, chemical resistant gloves (e.g., neoprene or butyl rubber) and appropriate personal protective equipment to protect bare skin when there is a risk of contact with refrigerant.

### Actions in case of exposure

**Eye contact:** Rinse with warm water and apply a light bandage. Seek medical attention immediately.

**Limited skin contact:** Rinse with warm water and apply a light bandage. Seek medical attention immediately.

**Extensive skin contact:** Rinse with warm water and carefully heat the area with warm water or warm clothing. Seek medical attention immediately.

**Inhalation:** Leave the area and find fresh air. Seek medical attention immediately.



## Handling line, tubes and hoses

### **WARNING**

Risk of high pressure injection.

Oil or fuel leaks from high pressure hoses could cause serious injury caused by high pressure injection.

**If oil or fuel leaks from high pressure hoses or loose screws are found, stop operations immediately and contact a qualified service technician.**

- Do not bend high pressure lines.
- Do not strike high pressure lines.
- Do not install any lines that are bent or damaged.
- Check lines, tubes and hoses carefully. (leakage, damage, deformity and aging)
- Do not reuse hose, tube and fittings.
- Do not use your bare hand to check for leaks.
- Tighten all connections. Consult your Volvo Construction Equipment dealer for the recommended tightening torque.

If any of the following conditions are found, replace the parts. Consult your Volvo Construction Equipment dealer.

- Connections and end fittings are damaged, leaking, deformed or aged.
- Outer coverings are chafed or cut.
- Strengthening wires are exposed.
- Outer coverings are ballooning.
- Flexible part of the hoses are kinked.
- End fittings are displaced.
- Foreign material is embedded in the coverings.

### **NOTICE**

**Make sure that all clamps, guards and heat shields are correctly installed. This contributes to preventing vibrations, chafing against other parts and excessively strong generation of heat.**



V1068256

## Maintenance

If the machine is to function satisfactorily and at lowest possible cost, it requires careful maintenance.

Regarding intervals for other maintenance, see the "Service Programme" or the "Lubrication and Service Chart" in this chapter.

### Lubrication and service chart

The section "Lubrication and service chart" describes the maintenance work which the operator can carry out. If certain operations require trained workshop personnel and special equipment, this will be indicated.

### Service history

After each completed service by a qualified service technician, the service history should be filled in, see page 469. Service history is a valuable document, which is referred to when selling the machine.

### Arrival Inspection

Before the machine leaves the factory, it is tested and adjusted. The dealer or distributor must also carry out arrival inspections according to the applicable form.

### Delivery Inspection

Before the machine leaves the factory, it is tested and adjusted. The dealer or distributor must also carry out delivery inspections according to the applicable form.

### Delivery Instructions

When handing the machine over, the dealer must give the buyer "Delivery instructions" according to



## Maintenance

280

---

applicable form, which must be signed, if the warranty is to apply.

### **Service Programme**

For any factory warranty to be valid, the machine shall be maintained according to the service program established by Volvo. The service program is continuous with fixed intervals. The operating time between intervals only applies if the machine is used in normal environment and operating conditions. Ask your Volvo dealer what is right for your specific machine.



---

## Lubrication and service chart

### Lubrication

Lubrication is an important part of preventive maintenance. The service life of bushings, bearings and bearing pins can be extended considerably if the machine is lubricated in a correct way. A lubrication chart makes lubrication work easier and reduces the risk of forgetting greasing points.

**Lubrication has two main purposes:**

- To supply grease to the bearing in order to reduce wear between the pin and the bearing.
- To replace old and dirty grease. The grease stored inside the outer seal collects dirt and water and prevents them from penetrating into the bearing.

### **NOTICE**











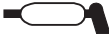



Wipe off grease nipples and grease gun before greasing, so that dirt and sand are not introduced through the grease nipples into the bearings.

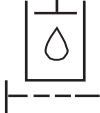
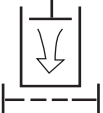

282 Maintenance  
Lubrication and service chart

**Symbol key**

These standard symbols are used in the Lubrication and service chart, see the adjacent table.

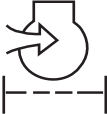
 1 Engine oil	 2 Grease lubrication	 3 Swing drive gear oil change
 4 Swing drive gear oil check	 5 Track drive gear oil check	 6 Track drive gear oil change
 7 Hydraulic oil	 8 Hydraulic oil level	 9 Hydraulic oil filter
 10 Hydraulic tank, air breather filter	 11 Fuel filter	 12 Water separator
 13 Engine, coolant	 14 Engine, coolant filter	 15 Engine coolant level
 16 Engine oil level	 17 Engine oil filter	 18 Operator manual
 19 Air cleaner filter		

### Lubrication and service chart

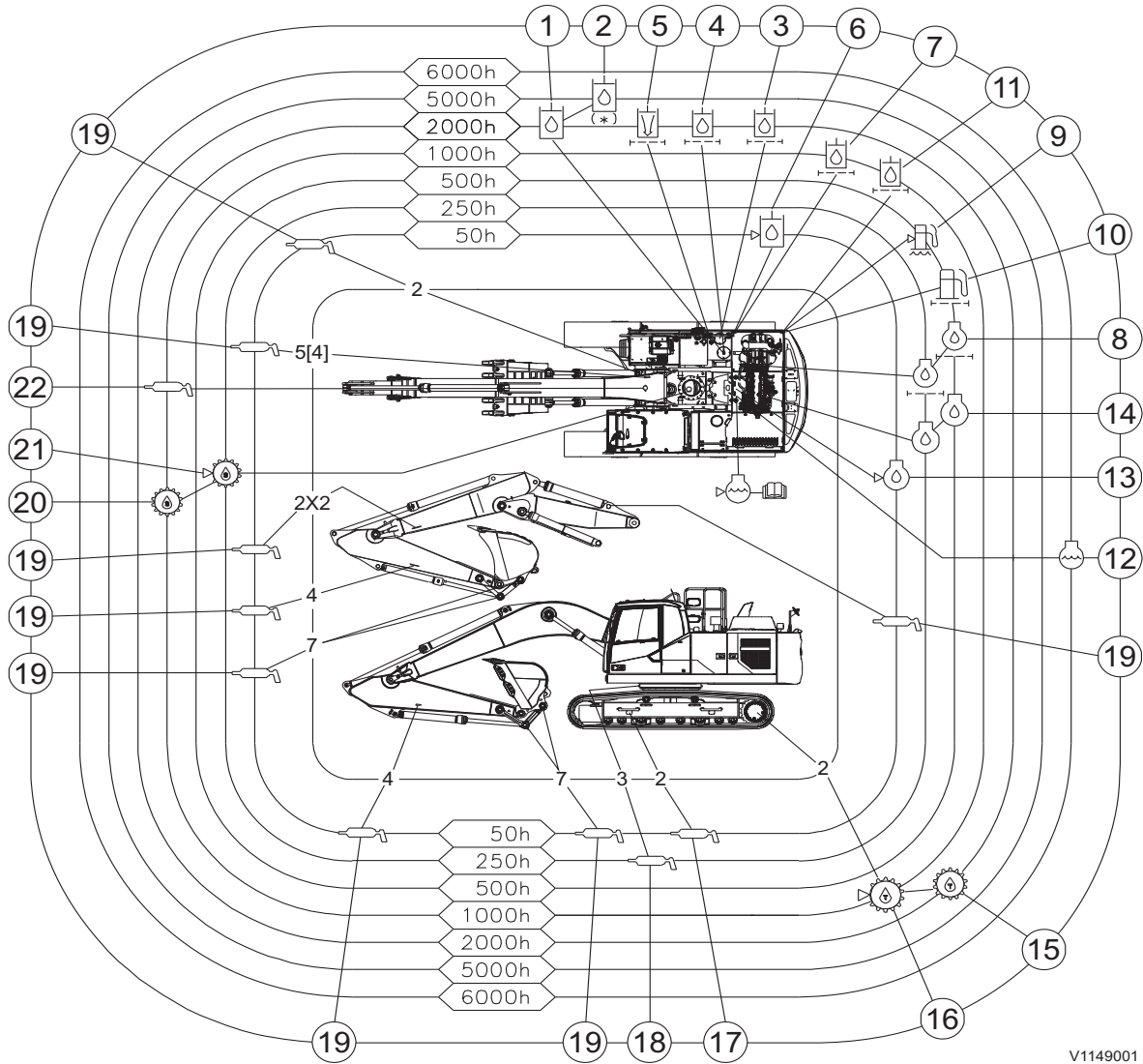

V1149001



**284**      **Maintenance**  
**Lubrication and service chart**

<b>When required</b>	<b>Item</b>	<b>Page</b>
Check the coolant level <sup>(1)</sup>	-	331
Check and drain the water separator <sup>(1)</sup>	-	319
Drain the sediment from fuel tank	Workshop job <sup>(2)</sup>	-
Clean the primary filter of air cleaner <sup>(1)</sup>	-	326
Clean the screen filter of the oil bath air cleaner <sup>(1)</sup>	-	331
<b>DAILY (every 10 hours)</b>	<b>Item</b>	<b>Page</b>
Check the track shoe screws	-	289
Check the washer fluid level	-	290
<b>Every 50 hours</b>	<b>Item</b>	<b>Page</b>
Check the engine oil level, or <sup>(1)</sup>	13	291
Check the hydraulic oil level	6	292
Check the oil level of oil bath air cleaner	-	292
Check the track tension	17	294
Lubricate to attachments	19	296
<b>Every 250 hours after carrying out Daily and 50 hours services</b>	<b>Item</b>	<b>Page</b>
Check the oil level of swing drive unit	21	299
Clean the cab prefilter	-	301
Lubricate the swing gear bearing	18	300
Change the oil bath air cleaner oil	Workshop job <sup>(2)</sup>	-
Change the return filter for hydraulic breaker (X1) When heavy use of hydraulic breaker (X1), see page 359 for service intervals.	Workshop job <sup>(2)</sup>	-
Drain the water from the air compressor tank (2 times per 250 hours in humid weather)	-	301
Clean the air filter of the air compressor	-	301

1. Check according to the signal on IC (Instrument Cluster)  
2. Contact a workshop authorized by Volvo



Maintenance  
Lubrication and service chart **285**

Every 500 hours after carrying out Daily, 50 and 250 hours services	Item	Page
Perform the parked service regeneration to reset EATS before changing the engine oil	Workshop job <sup>(1)(2)</sup>	-
Change the engine oil <sup>(3)</sup> and oil filter	8, 14 Workshop job <sup>(2)</sup>	-
Change the fuel filter	10 Workshop job <sup>(2)</sup>	-
Change the water separator filter element	9 Workshop job <sup>(2)</sup>	-
Clean the radiator, oil cooler and condenser fins <sup>(4)</sup>	-	303
Clean the main filter of air conditioner	-	305
Change the main filter of air conditioner (HEPA filter, optional equipment)	-	305
Check the battery electrolyte level (every 250 hours at temperature above +30 °C (+86 °F))	-	307
Check the belt tension for air conditioning	Workshop job <sup>(2)</sup>	-

1. Volvo's service tool is required
2. Contact a workshop authorized by Volvo
3. Or at least once a year
4. Or when required





**286**      **Maintenance**  
**Lubrication and service chart**

Every 1000 hours after carrying out Daily, 50, 250 and 500 hours services	Item	Page
Check the oil level of track drive unit	16	309
Check the swing bath grease	22	309
Lubricate to the cab door hinges	-	309
Check the overload warning system	-	310
Change the hydraulic servo filter <sup>(1)</sup>	11 Workshop job <sup>(2)</sup>	-
Change the hydraulic oil drain filter <sup>(1)</sup>	7 Workshop job <sup>(2)</sup>	-
Change the oil of swing drive unit <sup>(1)</sup>	20 Workshop job <sup>(2)</sup>	-
Check the belt tension for alternator	Workshop job <sup>(2)</sup>	-
Check the software update <sup>(3)</sup>	Workshop job <sup>(2)</sup>	-

1. First change: 500 hours
2. Contact a workshop authorized by Volvo
3. At least once a year



Maintenance  
Lubrication and service chart **287**

Every 2000 hours after carrying out Daily, 50, 250, 500 and 1000 hours services	Item	Page
Check the coolant content <sup>(1)</sup>	-	312
Clean the suction strainer of hydraulic tank <sup>(2)</sup>	3 Workshop job <sup>(3)</sup>	-
Change the primary filter of air cleaner <sup>(4)</sup>	-	311
Change the cab prefilter	-	311
Change the air breather filter on hydraulic tank	5 Workshop job <sup>(3)</sup>	-
Change the air ventilation filter on fuel tank	Workshop job <sup>(3)</sup>	-
Change the oil of track drive unit <sup>(5)</sup>	15 Workshop job <sup>(3)</sup>	-
Change the hydraulic oil (mineral oil) <b>If Hydraulic Breaker (hammer) is equipped, change the hydraulic oil according to frequency of HB use</b> - Frequency of HB use (50%): every 1000 hours - Frequency of HB use (100%): every 600 hours	1 Workshop job <sup>(3)</sup>	-
Change the hydraulic oil return filter <sup>(5)</sup> <b>If Hydraulic Breaker (hammer) is equipped, change the hydraulic return filter according to frequency of HB use</b> - Frequency of HB use (50%): every 1000 hours - Frequency of HB use (100%): every 500 hours	4 Workshop job <sup>(3)</sup>	-
Change the main filter of air conditioner	-	311
Check the valve clearance	Workshop job <sup>(3)</sup>	-
Clean the screen filter of the oil bath air cleaner	-	311
Change the air filter of the air compressor	-	313

1. Or every year
2. Or when required
3. Contact a workshop authorized by Volvo
4. At least once a year
5. First change: 500 hours



**288** Maintenance  
**Lubrication and service chart**

Every 4000 hours after carrying out Daily, 50, 250, 500, 1000 and 2000 hours services	Item	Page
Change the secondary filter every 3rd time primary filter is replaced <sup>(1)</sup>	-	314
Change the CareTrack backup battery (at least every 3 years)	Workshop job <sup>(2)</sup>	-

Every 5000 hours after carrying out Daily, 50, 250, 500, 1000, 2000 and 4000 hours services	Item	Page
Change the hydraulic oil (bio oil and long life hydraulic oil) <b>If Hydraulic Breaker (hammer) is equipped, change the hydraulic oil according to frequency of HB use</b> - Frequency of HB use (50%): every 1000 hours - Frequency of HB use (100%): every 600 hours	2 Workshop job <sup>(2)</sup>	-

Every 6000 hours after carrying out Daily, 50, 250, 500, 1000, 2000, 4000 and 5000 hours services	Item	Page
Change the coolant <sup>(3)</sup>	12 Workshop job <sup>(2)</sup>	-
Change the air breather filter on AdBlue®/DEF tank	Workshop job <sup>(2)</sup>	-
Change the AdBlue®/DEF pump unit filter	Workshop job <sup>(2)</sup>	-

Every 8000 hours after carrying out Daily, 50, 250, 500, 1000, 2000, 4000, 5000 and 6000 hours services	Item	Page
Clean the diesel particulate filter	Workshop job <sup>(2)</sup>	-

1. Or at least every 2 years
2. Contact a workshop authorized by Volvo
3. Or at least every 4 years

## Maintenance service, every 10 hours

### Track unit, checking shoe screws

Check the shoe screws daily.

If track shoe screws (A) are loose, the track shoes are likely to be damaged.

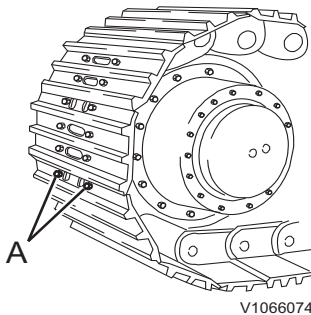

A Shoe screw

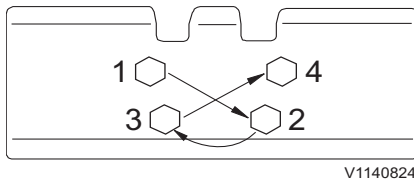

Order to tighten the screws

- 1 Swing the superstructure to the side and raise the track using boom down operation.
- 2 Turn the track slowly in forward and reverse direction several time. Check for missing, loose or damaged shoe screws and shoes. If needed, tighten the screws to specified torque,  $85 \pm 5 \text{ kgf m}$  ( $834 \pm 49 \text{ N m}$ ) ( $614 \pm 36 \text{ lbf ft}$ )

### **NOTICE**

It is very important that loose track shoe screws and nuts are removed fully and that the threads are cleaned. Clean the track shoes before they are installed and the screws tightened.

- 3 After tightening, check whether the nut and the shoe are in full contact with the mating surfaces of the link.

Tighten the screws in the order as shown in the figure.

290 Maintenance  
Maintenance service, every 10 hours

---

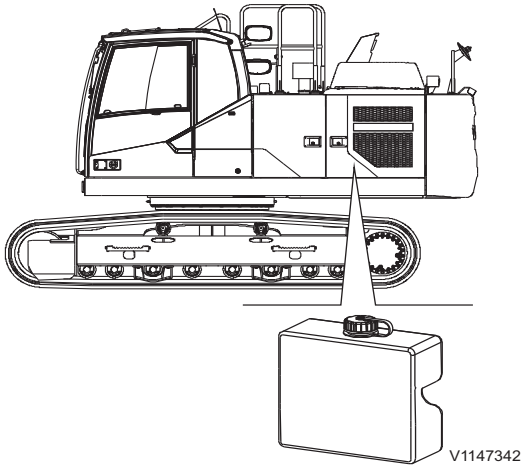

Washer reservoir

### Washer reservoir

Check the fluid level daily.

**NOTE!**

When the temperature is below freezing point, anti-freeze should be added to the washer fluid. Follow the manufacturer's recommendations as regards the ambient temperature.

### Excavator unit, greasing

Grease the excavator unit every 10 hours or daily only during first 100 hours.

After first 100 hours of operation, grease the excavator unit every 50 hours or weekly.

See page 296.

## Maintenance service, every 50 hours

### Engine oil level, checking

#### WARNING

Risk of serious injury.

Rotating parts could cause serious cutting or crushing injury.

**Never open the engine hood when the engine is running.**

Check the oil level when the check screen for low engine oil level pops up in the front instrument panel, see page 43. Aside from this, check the oil level every 50 hours.

#### NOTE!

Check the oil level when the machine has cooled down. (at least 30 minutes after turning off the engine)

- 1 Position the machine on even, firm and level ground.
- 2 Open the engine hood.
- 3 Pull out dipstick (A) and wipe it with a clean cloth.
- 4 Push it in and pull it out again.
- 5 If the oil level is between (C) and (D), it is normal. If the oil level is below (D), refill the oil to proper level through filler port (B). For the recommended engine oil, see page 343.

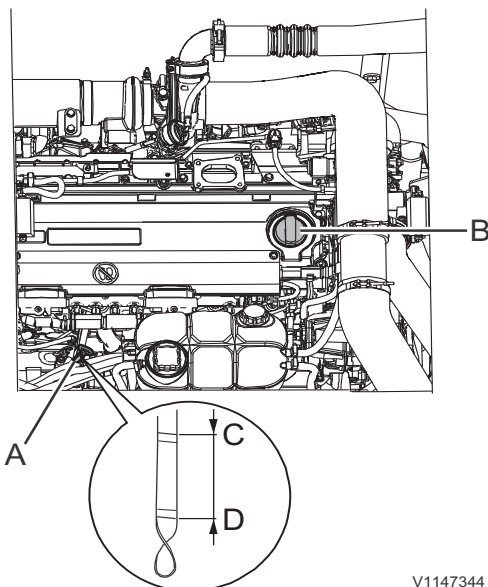

V1147344

- A Dipstick
- B Filler port
- C Oil level, High
- D Oil level, Low

292 Maintenance  
Maintenance service, every 50 hours

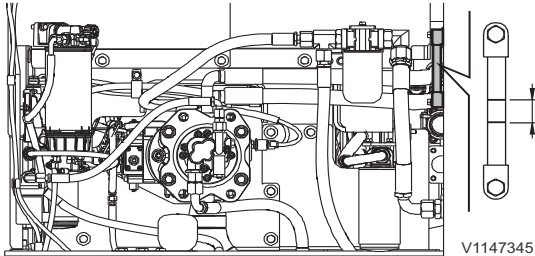

V1147345

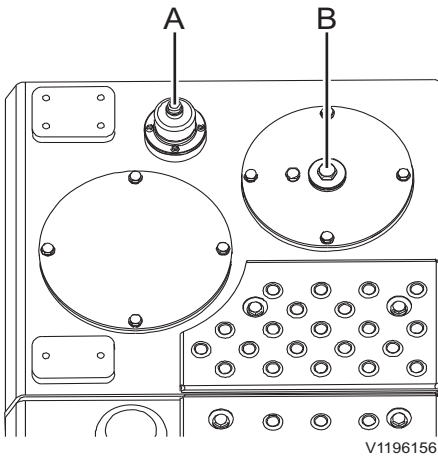

V1196156

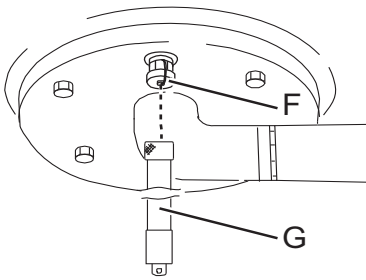

V1093465

## Hydraulic oil level, checking

Check the oil level every 50 hours.

- 1 Park the machine in service position B, see page 262.
- 2 Move the control lockout lever down to lock the system securely and stop the engine.
- 3 Open the side door on the right side of the machine and check the oil level in the sight gauge. If the level is in the center of the gauge, the level is correct.
- 4 If the level is low,
  - Press breather (A) to release the internal pressure at the tank.
  - Remove filling plug (B) and top up with hydraulic oil.

### NOTE!

To top up the oil efficiently press air breather again.

- Check the level.
- If the level is normal, install the filling plug.

### NOTICE

Use the same hydraulic oil that is already in the system. The hydraulic system may be damaged if different brands of hydraulic oil are mixed.

- 5 If the level is high,
  - Place a suitable sized container under the hydraulic tank.
  - Remove the protecting cap (F) and attach drain hose (G).
  - Drain the oil into a container.

### NOTICE

Take care of filters, oils and liquids in an environmentally safe way.

- Disconnect the drain hose and install the protecting cap.

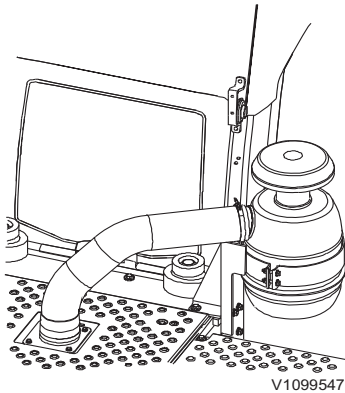

## Oil bath air cleaner, checking

**Check the oil level every 50 hours.**

When working in a particularly dusty environment, the oil bath air cleaner may be installed in series with the existing dry type air cleaner. This will provide further safety against damage to the engine.

The removable and fixed filters are the most sensitive operational parts of the air cleaner. Unless they are kept clean, the air cleaner cannot function properly. A plugged filter not only leads to excessive engine wear, but can also cause loss in engine power.

The screen filter assembly should be removed from the oil cup and inspected every 50 hours.



## Track unit, checking tension

Check the track tension every 50 hours.

### **WARNING**

Risk of crushing.

Raised equipment may drop if the hydraulic system fails or if the control is operated. Falling equipment may cause serious injury or death.

**Always make sure that raised equipment is supported by a mechanical device before walking or working under it.**

### **NOTE!**

To check the track tension, the track must be raised off the ground.

When two persons are working, the operator should follow the sign of the maintenance worker.

The degree of wear condition of track link pins and bushings varies with the working condition or the characteristics of soil. Check the track tension often and keep it to the specified value.

When working in wet sand or clay, it sticks to and packs between moving undercarriage components. This can prevent mating parts from properly engaging each other, which cause interference and high loads. Due to abrasive particles in the material it significantly accelerates wear rates of the sprockets, pins / bushings, idlers and track links as the track load and tension increase. Generally, packing effects cannot be controlled except by constant cleaning or removal of the material.

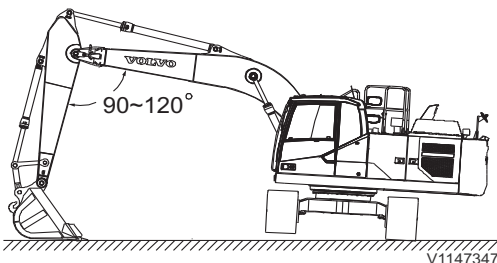

Maintenance  
**Maintenance service, every 50 hours** **295**

Therefore thoroughly clean the undercarriage at least daily or more often according to soil conditions in job-site.

- 1 Swing the superstructure to the side and raise the track by using boom and dipper arm. For this movement, operate the lever slowly.
- 2 Turn the track slowly in forward and reverse direction several time. Stop the track while moving in the reverse direction.
- 3 Measure the track slack (L) at the center of track frame, the clearance between the bottom of track frame and the upper surface of track shoe.
- 4 Adjust the track tension according to the soil characteristics.

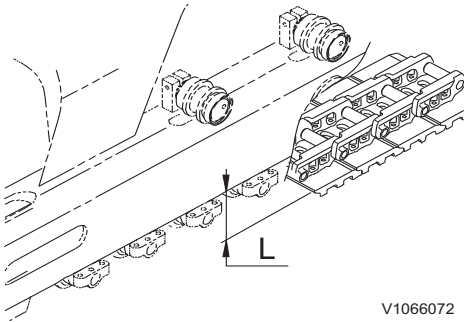

V1066072

Recommended track tension is as below,

Working condition	Clearance ( L ) (mm) (in)
General soil	320 - 340 (12.6 - 13.4)
Rocky ground	300 - 320 (11.8 - 12.6)
Moderate soil like gravel, sand, snow, and so on.	340 - 360 (13.4 - 14.2)



### Excavator unit, greasing

Grease the excavator unit every 50 hours or weekly.

During the first 100 hours, the excavator unit should be greased every 10 hours or daily.

#### **NOTE!**

Under severe operating conditions where mud, water, and abrasive material may enter the bearings, or after using the hydraulic hammer, the excavator unit should be greased every 10 hours or daily.

When greasing by hand, lower the attachment to the ground as illustrated, and stop the engine. Grease through the grease nipples using a hand or power grease gun. After greasing, clean off the superfluous grease.

Immediately after working under water, grease the submerged parts such as the bucket pins to remove the old grease, regardless of the grease interval. For grease specification, see page 343.

Maintenance  
Maintenance service, every 50 hours **297**

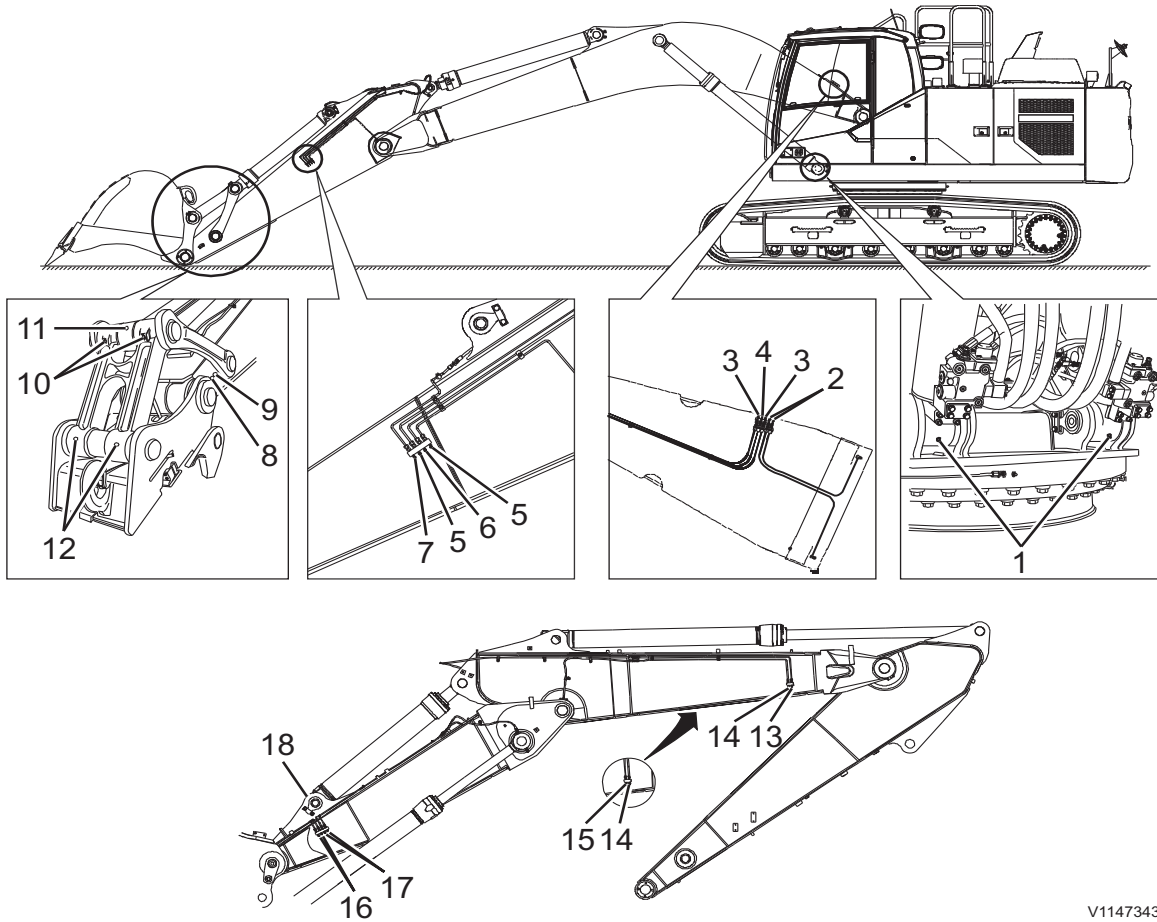

V1147343

- |   |   |
|---|---|
| 1 Boom cylinder mounting pin (2 points)       | 10 Pin between connecting rod and link (2 points)   |
| 2 Boom mounting pin (2 points)                | 11 Bucket cylinder rod end pin (1 point)            |
| 3 Boom cylinder rod end pin (2 points)        | 12 Pin between bucket and connecting rod (2 points) |
| 4 Dipper arm cylinder mounting pin (1 point)  | 13 Second boom cylinder rod end pin (1 point)       |
| 5 Pin between boom and dipper arm (2 points)  | 14 Pin between boom and second boom (2 points)      |
| 6 Dipper arm cylinder rod end pin (1 point)   | 15 Dipper arm cylinder mounting pin (1 point)       |
| 7 Bucket cylinder mounting pin (1 point)      | 16 Boom mounting pin (2 points)                     |
| 8 Pin between dipper arm and bucket (1 point) | 17 Boom cylinder rod end pin (2 points)             |
| 9 Pin between dipper arm and link (1 point)   | 18 Second boom cylinder mounting pin (1 point)      |



## Maintenance service, every 250 hours

### Swing drive unit

#### **NOTICE**

Always clean around the oil dipstick before you check the oil level. Dirt in the oil damages the swing gearbox.

It is very important that the oil level is always correct and that it is checked at working temperature.

- **Too little oil** may lead to insufficient lubrication of the swing drive unit and cause costly damage.
- **Too much oil** may lead to oil foaming, and cause the swing drive unit to overheat.



#### **WARNING**

Risk of burns!

Hot liquids and machine parts can cause burns.

**Allow the machine to cool before beginning any service.**

## Swing drive unit, checking oil level

Check the oil level every 250 hours.

- 1 Pull out oil dipstick (A) and wipe it with a clean cloth.
- 2 Insert oil dipstick and pull it out again.
- 3 Check the oil level. If the level is in the center of "D", the level is correct.
- 4 If the level is low, top up oil through oil filler hole (B) to correct level.
- 5 If the level is high,
  - Remove the under cover (C).
  - Place a suitable sized container under the drain valve (E).
  - Open the protection cap of drain valve (E).
  - Attach the drain hose (F) and drain the oil to the correct level.
  - Disconnect the drain hose.
  - Close the protecting cap.

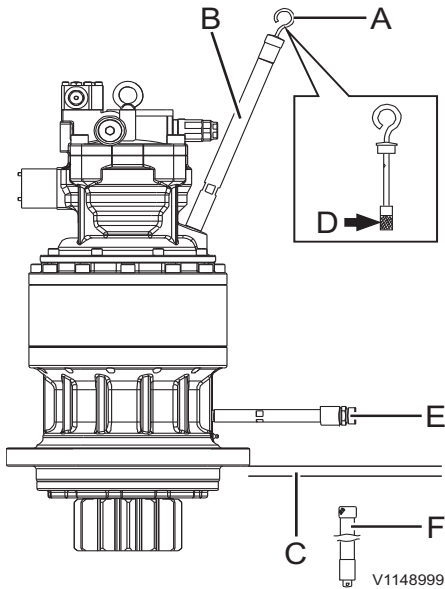

For oil specification, see page 343.

**300 Maintenance**  
**Maintenance service, every 250 hours**

---

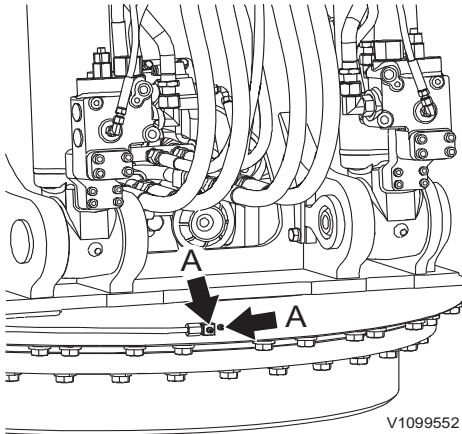

### Swing gear bearing, greasing

Grease the swing gear every 250 hours.

- 1 Park the machine on level ground.
- 2 Lower the bucket to the ground.
- 3 Move the control lockout lever down to lock the hydraulic system securely and stop the engine. See page 109.
- 4 Fill the grease in the grease nipples (A) using a hand or power grease gun.
- 5 Apply grease to the swing bearing until grease can be seen from the swing bearing seals.
- 6 Take care not to supply excessive amount of grease.
- 7 After greasing, clean off the superfluous grease completely.

## Cab prefilter, cleaning and replacing

If the cab prefilter is clogged, the fresh air flow rate will be reduced. Therefore, clean it periodically.

Clean the cab prefilter every 250 hours and replace it every 2000 hours.

### WARNING

Risk of hazardous inhalation.

Dangerous dust can lead to serious health problems.

**Always wear personal protective equipment, including filter mask, eye protection and appropriate gloves when handling and cleaning the engine compartment, coolers and air filters.**

- 1 Turn the screw to counter clockwise using a L wrench.
- 2 Tilt the cover (B) towards rear side and take out the prefilter (A).
- 3 Clean the prefilter with compressed air.

#### NOTE!

When using compressed air, keep the nozzle at a distance from the filter to prevent damage. Clean the filter with compressed air with a maximum pressure of 0.2 MPa (2 kgf cm<sup>2</sup>) (29 psi).

- 4 If the prefilter is damaged or heavily contaminated, replace it with a new one.
- 5 Install the prefilter and close the cover.

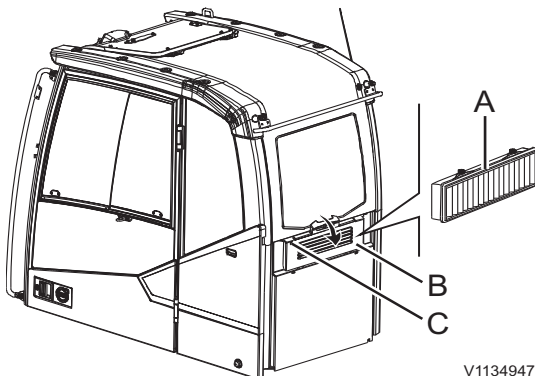

V1134947

- A Cab prefilter
- B Cover
- C Screw

## Air compressor, air tank water, draining

Drain the water from the air compressor tank every 250 hours.

#### NOTE!

Drain the water 2 times per 250 hours in humid weather.

- 1 Open drain valve (B) under air compressor tank (A) and drain the water from the tank.
- 2 Close the drain valve.

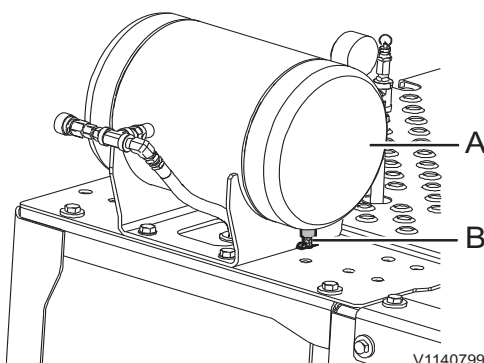

V1140799

- A Air compressor tank
- B Drain valve



302 Maintenance  
Maintenance service, every 250 hours

### Air compressor, air filter, cleaning

Clean the air filter of the air compressor every 250 hours.

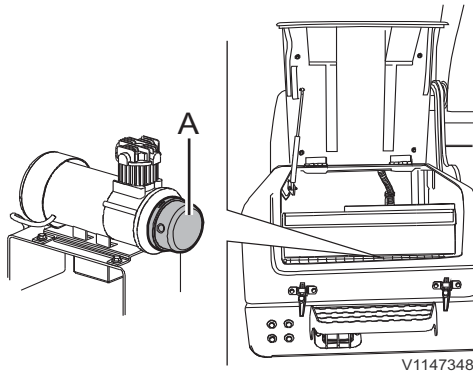

A Air filter cover

#### **WARNING**

Risk of hazardous inhalation.

Dangerous dust can lead to serious health problems.

**Always wear personal protective equipment, including filter mask, eye protection and appropriate gloves when handling and cleaning the engine compartment, coolers and air filters.**

- 1 Open the tool box on the machine's right side.
- 2 Remove air filter cover (A) by turning clockwise slightly.
- 3 Clean the air filter inside the cover with compressed air.
- 4 Install the cover.

## Maintenance service, every 500 hours

### Radiator and coolers, cleaning

Cleaning interval depends on the environmental condition the machine is operating. Therefore, clean all fins when required or at least every 500 hours.

#### **WARNING**

Risk of hazardous inhalation.

Dangerous dust can lead to serious health problems.

**Always wear personal protective equipment, including filter mask, eye protection and appropriate gloves when handling and cleaning the engine compartment, coolers and air filters.**

#### **WARNING**

Risk of serious injury.

Compressed air, water jets or steam may cause damage to unprotected skin and eyes.

**Always wear personal protective gloves, goggles and clothing when using compressed air, water jets or steam.**

#### **NOTICE**

**DO NOT use steam to clean the condenser core. The refrigerant can overheat! When cleaning with water, protect the electrical components.**

If the engine temperature becomes too high even though the coolant level is correct, the radiator should be cleaned.

304 Maintenance  
Maintenance service, every 500 hours

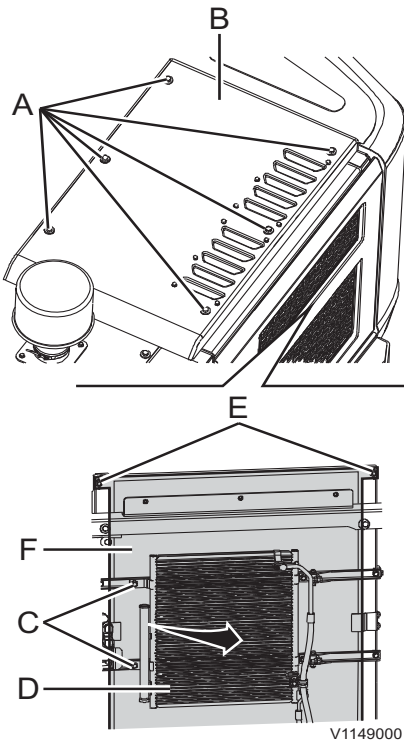

- A Screws
- B Radiator hood
- C Screws
- D Condenser
- E Wing nuts
- F Radiator screen

- 1 Open the left side door of the machine.
- 2 Remove screws (A) and radiator hood (B).
- 3 Remove screws (C) and swing out condenser (D).
- 4 Remove the leaves attached to the net and condenser.
- 5 Remove wing nuts (E).
- 6 Pull out radiator screen (F) and clean the screen.
- 7 Clean any mud, dust or leaves attached to the radiator fins and oil cooler fins with compressed air or steam.
- 8 Check the rubber hose for wear and cracks. If damaged, replace it. Check the hose clamp for looseness.
- 9 Reinstall the screen with the wing nuts and close the radiator hood with the screws.

**NOTICE**

When using compressed air, keep the nozzle at a distance from the fins to prevent damage. Damaged fins may cause leakage or overheating.

If the engine temperature still remains high after cleaning the cooler, contact a workshop authorized by Volvo for remedial action.



Maintenance

---

Maintenance service, every 500 hours 305

## Air conditioning filter, cleaning and replacing

If the air conditioner filter is clogged, the air flow as well as the cooling and heating capacity will be reduced. Therefore, clean it periodically.

### **WARNING**

Risk of hazardous inhalation.

Dangerous dust can lead to serious health problems.

**Always wear personal protective equipment, including filter mask, eye protection and appropriate gloves when handling and cleaning the engine compartment, coolers and air filters.**

### **NOTE!**

If the machine is operated in particularly dusty environment or in air with hazardous material to human such as asbestos, special filter should be used. Contact your Volvo dealer for more information.

### **NOTICE**

**Refrigerant R134a adds to the greenhouse effect and may not be released.**

**Clean the filter every 500 hours and replace it every 2000 hours.**

## Maintenance 306 Maintenance service, every 500 hours

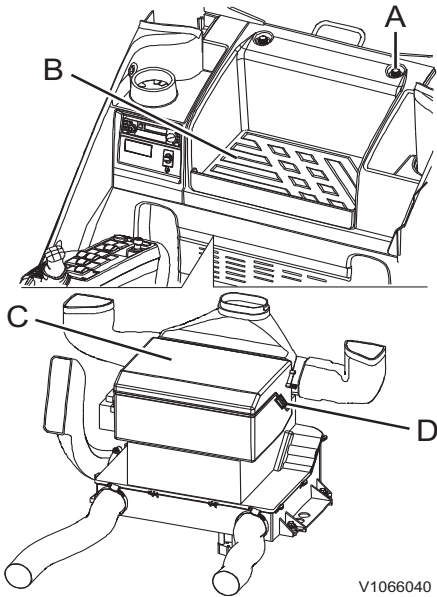

- A Screws (4 EA)
- B Rubber mat
- C Cover
- D Latches (4 EA)

- 1 Unscrew 4 screws (A). Two are under rubber mat (B).
- 2 Disconnect the wire harness of the air conditioner.
- 3 After opening the 4 latches (D), open the cover (C) and take out the filter.
- 4 Clean the filter with compressed air.

### NOTE!

When using compressed air, keep the nozzle at a distance from the filter to prevent damage. Clean the filter with compressed air with a maximum pressure of 0.2 MPa (2 kgf cm<sup>2</sup>) (29 psi).

- 5 If the filter is damaged or heavily contaminated, replace it with a new one.
- 6 Install the filter, and assemble them in reverse order.

### High Efficiency Particulate Air filter (HEPA, optional equipment)

**Do not reuse or clean HEPA filter. Only replace the filter with a new one every 500 hours.**

### NOTE!

Filter changes are to be done by a qualified service technician, and HEPA filter must always be handled with extra care. When changing HEPA filter, the used filter shall be placed in the plastic bag that is supplied with a new filter. Never shake the filter, place it carefully in the supplied plastic bag. Then the plastic bag shall be sealed and deposited with at a suitable location for hazardous waste, such as asbestos waste.

### WARNING

Risk of hazardous inhalation.

Dangerous dust can lead to serious health problems.

**Always wear personal protective equipment, including filter mask, eye protection and appropriate gloves when handling and cleaning the engine compartment, coolers and air filters.**

## Battery electrolyte level, check

Check the electrolyte level every 500 hours.

### NOTE!

Check the electrolyte level every 250 hours at temperature above +30 °C (+86 °F).

### NOTICE

Do not keep objects in the battery box that may damage the cables.

### ! WARNING

Risk of fire and explosion.

Battery gas contains hydrogen and is flammable and could explode.

Do not open a battery close to sources of fire such as open flames, cigarettes or sparks.

### ! WARNING

Risk of chemical burns.

The battery electrolyte contains corrosive sulphuric acid which could cause severe chemical burns.

If electrolyte spilled on your bare skin, remove it immediately and wash the affected area with soap and plenty of water. If it gets into your eyes or any other sensitive body part, rinse with plenty of water and seek immediate medical attention.

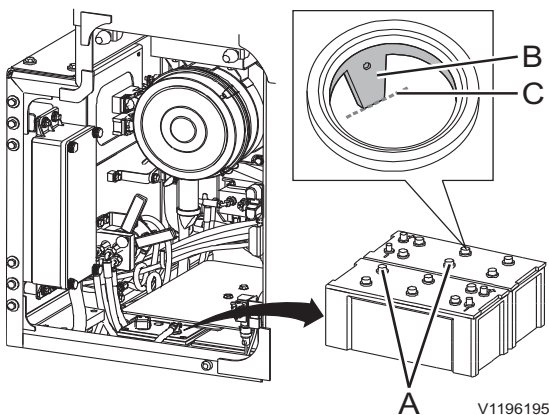

- 1 Open the left side door of the machine.
- 2 Ensure the battery disconnect switch is at off position and remove the battery cover.
- 3 Remove all battery cell caps (A) and check the electrolyte level for each cell with level indicator (B) inside of the battery cell.

### NOTE!

The electrolyte level should be up to the end of level indicator (C) as shown in the illustration.

- 4 Refill distilled water up to the end of level indicator (C) when required.
- 5 Install the battery cell caps.
- 6 Check that the cable terminals and battery terminals are clean, well tightened and coated with petroleum jelly or similar product.
- 7 Install the battery cover.

## Maintenance service, every 1000 hours

### Track drive unit

#### **NOTICE**

Always clean around the level plug before you check the oil level. Dirt in the oil damages the track gearbox.

It is very important that the oil level is always correct and that it is checked at working temperature.

- **Too little oil** may lead to insufficient lubrication of the track drive unit and cause costly damaged.
- **Too much oil** makes the oil foaming and cause the track drive unit to overheat.



#### **WARNING**

Risk of burns!

Hot liquids and machine parts can cause burns.

**Allow the machine to cool before beginning any service.**



#### **WARNING**

Risk of high pressure injection.

Residual pressure in the hydraulic system could lead to oil under high pressure jetting out and cause serious injury, even if the engine has not been running for some time.

**Always release the pressure before any kind of service of the hydraulic system is carried out.**



## Track drive unit, checking oil level

Check the oil level every 1000 hours.

- 1 Turn the case so that drain plug (A) is located at the bottom.
- 2 Remove the level checking plug (B). If the oil is about to overflow from the hole, the level is correct.

If the oil is low, top up the oil to the correct level through the plug (B).

For oil specification, see page 343.

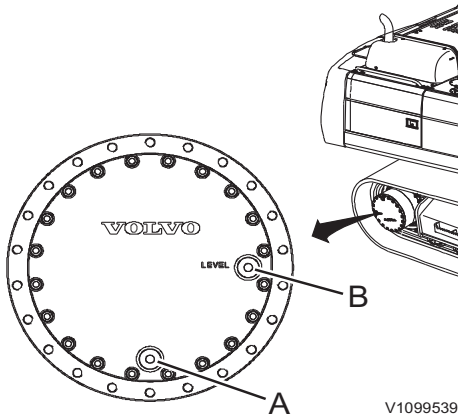

V1099539

## Swing bath, grease checking

Check the grease condition and level every 1000 hours.

- 1 Park the machine on a level ground and move the superstructure as shown in the figure.
- 2 Lower the bucket to the ground.
- 3 Turn the ignition switch to stop position.
- 4 Move the control lockout lever down to lock the system securely. See page 109.
- 5 Remove screws (B) and the cover (C).
- 6 Check the level and condition of the grease. Fill if needed.
- 7 Inspect the seal (D). Replace the seal if damaged.
- 8 Install the cover.

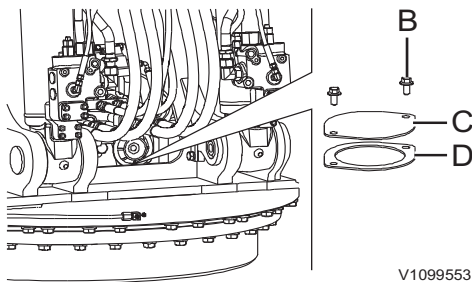

V1099553

### NOTE!

If the grease is contaminated or discoloured with water, contact a workshop authorized by Volvo for changing the grease.

## Cab door hinges, greasing

Grease the cab door hinges every 1000 hours.

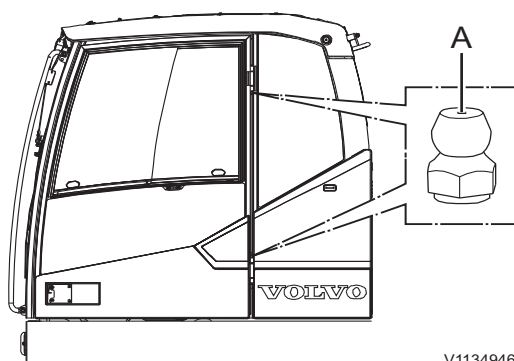

V1134946

A Grease points





## 310 Maintenance Maintenance service, every 1000 hours

---

### Overload warning

Check the overload warning system every 1000 hours according to below procedure.

- 1 Place the machine on level and firm ground.
- 2 Engage the overload warning with the button on the keypad, see page 79.
- 3 Operate the boom cylinders to their upper end positions.  
The overload warning signal should sound and the overload symbol should appear in the IC (Instrument Cluster). If not contact a qualified service technician.

## Maintenance service, every 2000 hours

### Engine air cleaner primary filter, replacing

See page 326.

### Oil bath air cleaner, cleaning

Clean the screen filter every 2000 hours or according to clogging signal.

The lower portion of the body assembly should be inspected each time the air cleaner is serviced. If there is any sign of build-up or plugging, the body assembly should be removed and cleaned. At least once a year, remove the body assembly and perform the following service steps:

- 1 Turn off the engine.
- 2 Open fasteners on air cleaner housing.
- 3 Carefully remove the oil container from the bottom.
- 4 Empty oil container and clean.

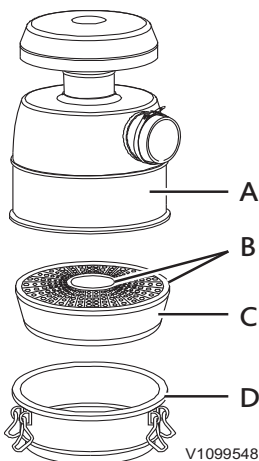

- A Air cleaner housing
- B Insert seal
- C Screen filter
- D Oil container

### **NOTICE**

Take care of filters, oils and liquids in an environmentally safe way.

- 5 Check seals for damage and replace if necessary.
- 6 Wash out the housing and screen filter with oil.
- 7 Fill oil container with engine oil exactly to the oil mark on the container.
- 8 Place oil container on the housing and close fasteners.
- 9 Take care the position is correct.

### Cab prefilter, cleaning and replacing

See page 301.

### Air conditioning filter, cleaning and replacing

See page 305.

312 Maintenance  
Maintenance service, every 2000 hours

---

## Coolant

### **NOTICE**

If the warning of high coolant temperature is shown on the display unit, the engine must be stopped immediately.

Check the coolant contents (%) every 2000 hours or every 1 year.

The cooling system is filled with Volvo Coolant VCS, which fulfils the highest requirements regarding freeze-, corrosion-, and cavitation protection. To avoid damage to the engine, it is very important that Volvo Coolant VCS is used when filling or changing the coolant.

Volvo Coolant VCS is yellow and a decal by the filling point shows that the system is filled with this coolant (see picture).



### **NOTICE**

Volvo Coolant VCS must never be mixed with any other coolant or corrosion protection to avoid damage to the engine.

The cooling system capacity when changing, see page 358.

If concentrated Volvo Coolant VCS and clean water (see page 347) is used, the table below shows the approximate amount of concentrated coolant needed for freezing protection. The content of Volvo Coolant VCS must never be less than 40% of the total mixture.

Maintenance

Maintenance service, every 2000 hours 313

If in doubt of the water's quality, use the ready-mixed Volvo Coolant VCS, which contains 40% concentrated coolant.

**NOTICE**

In order to avoid damage to engine and cooling system, different brands of coolant or corrosion protection must not be mixed.

Freeze protection down to	Content of concentrated coolant
-25 °C (-13 °F)	40%
-35 °C (-31 °F)	50%
-46 °C (-51 °F)	60%

**Air compressor, air filter, replacing**

Change the air filter of the air compressor every 2000 hours.

**WARNING**

Risk of hazardous inhalation.

Dangerous dust can lead to serious health problems.

**Always wear personal protective equipment, including filter mask, eye protection and appropriate gloves when handling and cleaning the engine compartment, coolers and air filters.**

- 1 Open the tool box on the machine's right side.
- 2 Remove air filter cover (A) by turning clockwise slightly.
- 3 Change the air filter inside the cover with a new one.
- 4 Install the cover.

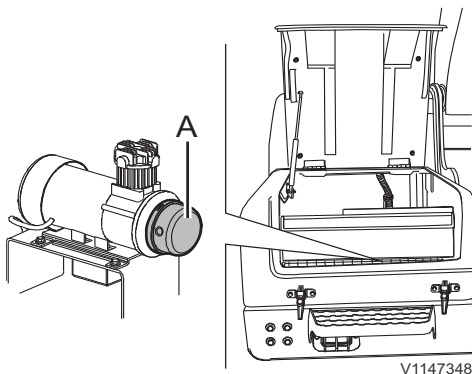

A Air filter cover



314 Maintenance  
Maintenance service, every 4000 hours

---

**Maintenance service, every  
4000 hours**

**Engine air cleaner secondary filter,  
replacing**

See page 329.

## Maintenance service, when required

### Engine oil level, checking

See page 291.

### Fuel, filling

#### **! WARNING**

Risk of fire.  
Burning fuel can cause fatal injuries.  
**Stop the engine before filling fuel.**

#### **! WARNING**

Risk of fire and explosion.  
A running auxiliary heater during fuel filling could cause fire and explosion.  
**Switch off the auxiliary heater before filling fuel.**

#### **NOTICE**

Risk of fuel tank contamination.  
Accidental filling of AdBlue®/DEF in to the fuel tank causes fuel tank contamination.  
Only use AdBlue®/DEF filling equipment that has a valve that opens only on machines equipped with a magnetic ring in the AdBlue®/DEF filler neck to avoid fuel tank contamination.

- 1 Carefully clean around the filler cap on the fuel tank before removing it.
- 2 Open the fuel filler cap (A) and fill the fuel in the tank.
- 3 Check the fuel level on IC (Instrument Cluster).  
See page 37.

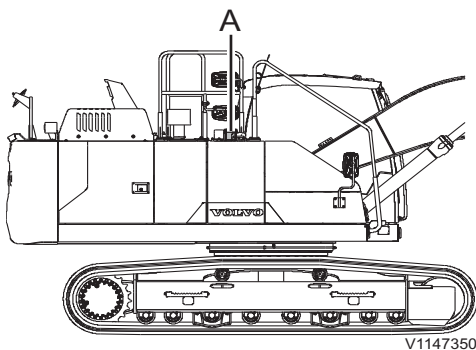

A Fuel filler cap

Avoid spilling the fuel when filling, which attracts dirt. If fuel is spilled, clean it up immediately.  
During the cold season, fill up the fuel tank to prevent water condensing in the tank.  
**For the capacity of fuel tank, see page 358.**

## 316 Maintenance Maintenance service, when required

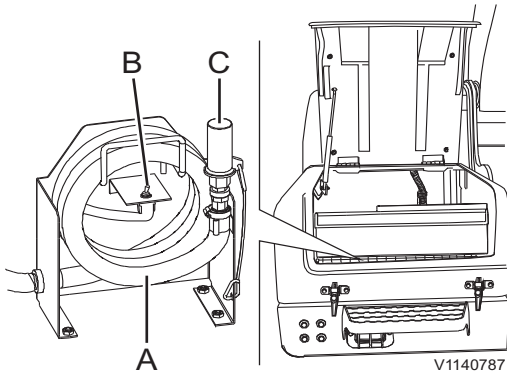

- A Fuel filler pump hose
- B Operating switch (ON / OFF)
- C Strainer cover

### Filling with electrical pump (optional equipment)

The pump is installed in the tool box. Use it when filling the fuel in a tank.

- 1 Remove the strainer cover (C) which is installed to protect the strainer from dust at the end of hose (A).
- 2 Put the pump hose with strainer into the fuel barrel.
- 3 Operate the switch (B) to start the pump.
- 4 Fill the fuel in the tank and check the fuel level on IC (Instrument Cluster).
- 5 Operate the switch to stop the pump when the fuel is filled enough.
- 6 Fold the hose and reinstall the strainer cover.

### NOTICE

Never allow the fuel filling pump to run dry. The pump may be damaged.

### Filling with auto shut-off controller (optional equipment)

This pump is provided with an electronic overfilling protection.

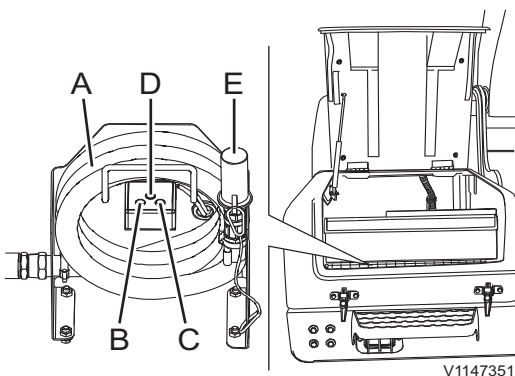

- A Fuel filler pump hose
- B Start button (green)
- C Stop button (red)
- D Manual control button
- E Strainer cover

- 1 Remove the strainer cover (E) which is installed to protect the strainer from dust at the end of hose (A).
- 2 Put the pump hose with strainer into the fuel barrel.
- 3 Press the green start button (B). The pump will run as long as the tank is not full.
  - At any time during the refuelling or when the drum has been emptied, the pump may be stopped by pressing the red button (C).
  - The pump will automatically stop when the fuel level sensor is actuated. The pump cannot be restarted until the fuel from the tank is used.
- 4 Fold the hose and reinstall the strainer cover.

## AdBlue®/DEF, filling

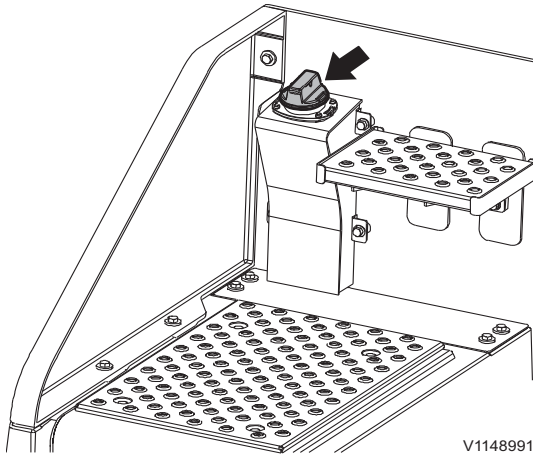

AdBlue®/DEF tank cap

### NOTICE

Risk of machine damage.  
Refilling fluids with anything other than what is specified in this manual could cause permanent damage to the catalyst system.  
Only refill fluids with those specified in this procedure.

### NOTICE

Risk of fuel tank contamination.  
Accidental filling of AdBlue®/DEF in to the fuel tank causes fuel tank contamination.  
Only use AdBlue®/DEF filling equipment that has a valve that opens only on machines equipped with a magnetic ring in the AdBlue®/DEF filler neck to avoid fuel tank contamination.

### NOTICE

Risk of machine damage.  
AdBlue®/DEF is highly corrosive. If the tank is overfilled, AdBlue®/DEF may leak out through the air vent pipe. If the tank is overfilled and the fluid in it freezes, the tank and hoses can be permanently damaged.  
Do not overfill the tank. Always stop filling when the fluid level reaches the filling port or when an automatic filling nozzle shuts off.

### NOTE!

Do not fill with any fluid other than that specified in ISO 22241-1. We recommend that you do not reuse drained AdBlue®/DEF due to the risk of contamination.

AdBlue®/DEF tank capacity, see page 358.

### NOTE!

Be careful not to overfill AdBlue®/DEF more than the tank capacity, otherwise it could overflow from the air breather line of the tank.

AdBlue®/DEF quality, see page 356.

If the AdBlue®/DEF level is low, an alarm indication is displayed. Fill the AdBlue®/DEF tank with AdBlue®/DEF.





## 318 Maintenance Maintenance service, when required

---

- AdBlue®/DEF is not classified as a hazardous substance but should still be handled with care. It is highly corrosive.
- If it comes into contact with the skin, rinse well with water.
- If it comes into contact with the eyes, rinse thoroughly for several minutes. Consult a doctor if necessary.
- If inhaled, breathe fresh air and contact a doctor if necessary.
- If swallowed, drink water and contact a doctor.
- Do not allow AdBlue®/DEF to come into contact with other chemicals.
- AdBlue®/DEF is not combustible. If AdBlue®/DEF is exposed to high temperatures it will decompose into ammonia and carbon dioxide.
- AdBlue®/DEF must not be mixed into the diesel tank and diesel must not be mixed into the AdBlue®/DEF tank.

### **NOTE!**

**AdBlue®/DEF filling equipment must be designed for a maximum filling rate of 40 litres/minute, and adjustable to a rate below 40 litres/minute. If filling problems occur and remain after the filling filter has been cleaned, please refer to the manual for the filling equipment and take the necessary action.**

**For distribution of AdBlue®/DEF (only valid for US market):**

- Volvo CE Customer Support: 1-877-823-1111 (business hours)
- [www.volvoce.com](http://www.volvoce.com) (outside business hours)

**For distribution of AdBlue®/DEF (all other markets), please contact your local Volvo dealer for more information.**

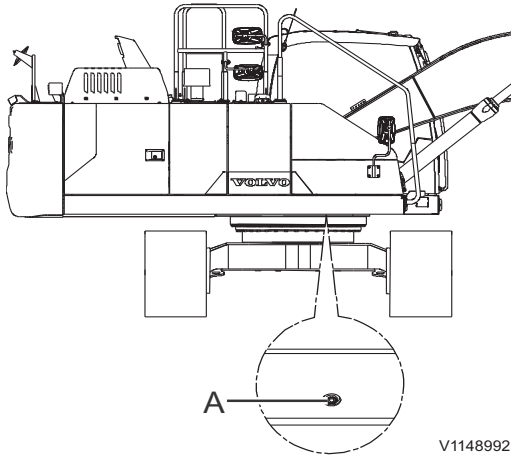

A Drain plug

V1148992

## AdBlue®/DEF tank, draining

- 1 Park the machine on a level ground and move the superstructure as shown in the figure.
- 2 Lower the bucket to the ground.
- 3 Turn the ignition switch to stop position.
- 4 Move the control lockout lever down to lock the system securely. See page 109.
- 5 Remove drain plug (A) using a L wrench from the tank.
- 6 Drain AdBlue®/DEF into a container.

### **NOTICE**

Take care of filters, oils and liquids in an environmentally safe way.

- 7 Install the drain plug to the tank.

## Water separator, draining

The water separator filter element is designed to remove the water from the fuel supplied to the engine.

Check and drain the water in the water separator filter element when the check screen for water in fuel pops up on the IC (Instrument Cluster).

- 1 Place a suitable sized container under drain hose (E).
- 2 Open the drain valve (C) and drain the sediment into a container.

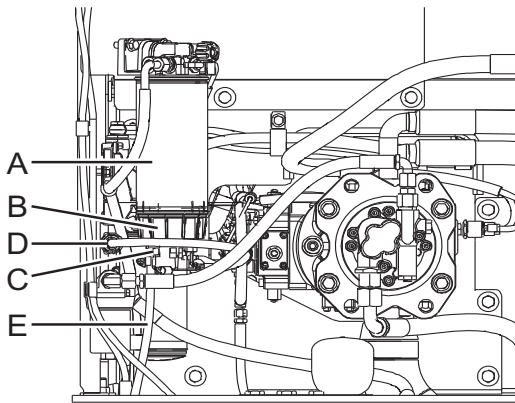

- A Filter element
- B Bowl
- C Drain valve
- D Sensor connector
- E Drain hose

V1148993

### **NOTICE**

Take care of filters, oils and liquids in an environmentally safe way.

- 3 Close the drain valve (C).

320 Maintenance  
Maintenance service, when required

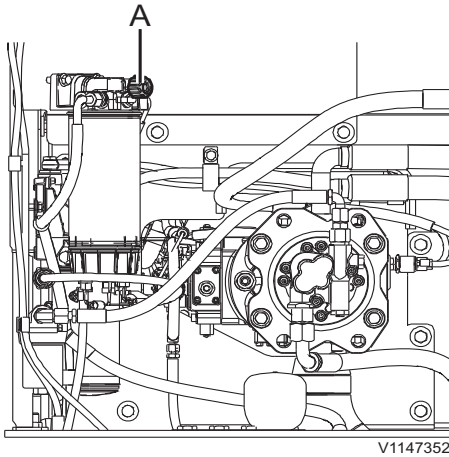

V1147352

A Hand pump

## Fuel system, bleeding

Air must be bled out of the fuel injection system whenever the machine runs out of fuel while the engine is running.

### **NOTICE**

Under no circumstances must starting attempts be made before the system has been bled. The fuel feed pump may be seriously damaged.

### **NOTE!**

Do not spill fuel on electrical components.

- 1 Turn hand pump (A) counterclockwise to unlock the plunger.
- 2 Pump hand pump (A) until a heavy resistance can be felt in the hand pump.
- 3 Push hand pump (A) fully and turn it clockwise to lock the plunger.
- 4 Start the engine and let it run in idle for 3 minutes.
- 5 If the engine is difficult to start, repeat (1) to (3).

### **NOTE!**

Do not use the hand pump when the engine is running.

- 6 Check for leakages.

## Batteries, charging

### WARNING

Risk of serious injury.

Short-circuit, open flames or sparks near a charging battery could lead to an explosion.

**Switch off charge current before disconnecting charging cable clamps. Never charge a battery near open flames or sparks. Always charge a battery in well-ventilated areas.**

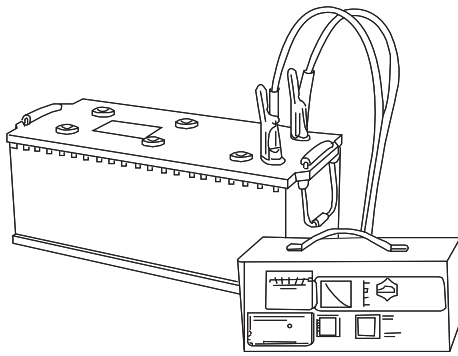

V1066032

### WARNING

Risk of chemical burns.

The battery electrolyte contains corrosive sulphuric acid which could cause severe chemical burns.

**If electrolyte spilled on your bare skin, remove it immediately and wash the affected area with soap and plenty of water. If it gets into your eyes or any other sensitive body part, rinse with plenty of water and seek immediate medical attention.**

- Always turn off the charging current before the charging lead clips are removed.
- Ventilate well, especially if the battery is charged in a confined space.

## Welding

The following measures should be taken before starting electric welding on the machine or attachments connected to the machine.

- 1 Turn off the electric power with the battery disconnect switch.
- 2 Disconnect the batteries, both the plus and minus terminal.
- 3 Disconnect the electronic units ; GPMECU1 (General Purpose Machine Electronic Control Unit1), EMS (Engine Management System), IC (Instrument Cluster), CCM (Climate Control Module) and so on. For further information, contact a workshop authorized by Volvo Construction Equipment.
- 4 Connect the welding equipment's ground connection as close to the welding point as possible and make sure that the current does not pass across a bearing.
- 5 Ventilate well, specially if the welding is performed in a confine space.
- 6 Remove all paint from an area of at least 10 cm (4 in) around the welding point.

### WARNING

Risk of toxin inhalation.

Burning of painted, plastic or rubber parts produces gases that could damage respiratory tracts.

**Never burn painted or rubber parts or any plastics.**

### NOTICE

**A fire extinguisher should be easily accessible during all welding work.**

### NOTE!

The weld will be related with inferior quality and strength, never weld directly on a painted surface.



## Cleaning machine

The machine should be cleaned regularly with conventional car care products in order to eliminate the risk of damage to the paint finish and other surfaces on the machine.

### **NOTICE**

Avoid using strong cleaning agents or chemicals in order to minimise the risk of damage to the paint finish.

### **NOTICE**

Soil and clay may damage or cause wear to moving parts of the undercarriage. Therefore, all parts must be cleaned regularly from of soil and clay.

### **NOTE!**

Daily clean the areas on the machine where dust, chips and similar may collect in order to minimise the risk of fire, see page 270.

- Place the machine in a place intended for cleaning.
- Follow the instructions supplied with the car care product.
- The water temperature must not exceed 80 °C (176 °F).
- If high-pressure wash is used, keep a distance of at least 40 cm (16 in) between the seals and the nozzle. Keep a distance of 30 cm (12 in) between nozzle and other machine surface. Too high pressure and too short distance may cause damage.



## 324 Maintenance Maintenance service, when required

---

### NOTE!

Protect electrical leads in an appropriate way and be careful not to damage the cab prefilter when cleaning the machine.

### NOTICE

Do not spray with high pressure into the sealing of the slewing ring, the water may penetrate and affect the characteristics of the grease.

- Use a soft sponge.
- Finish by rinsing the whole machine with only water.
- Always lubricate the machine after washing.
- Touch-up the paint finish when required.

### Paint finish maintenance

- Machines which are used in corrosive environment suffer more from rust than others. As a preventive measure it is recommended that the paint finish should be maintained every sixth months.
- At first clean the machine.
- Apply Dinol 77B (or corresponding transparent waxy anti-rust agent) at a thickness of 70-80 µ.
- A protective layer of underseal Dinitrol 447 (or corresponding) may be applied under the mudguards where mechanical wear is expected.

### Touch-up painting

- Check if there are any damaged areas of the paint finish.
- At first clean the machine.
- Rectify any damage to paint finish in a professional way.

## Cleaning engine compartment

### WARNING

Risk of serious injury.

Rotating parts could cause serious cutting or crushing injury.

**Never open the engine hood when the engine is running.**

### WARNING

Risk of burns.

Engine and exhaust system components get very hot and can cause severe burns.

**Avoid contact with engine compartment covers, engine components and exhaust system until the engine is cooled down.**

Machines operating in dusty environment or environment exposed to fire hazards for example, wood-processing, woodchip handling or grain handling and animal feed industries require daily attention and cleaning of the engine compartment and surrounding areas.

When operating in other environments, inspection and cleaning is required at least once a week.

Loose material is removed with for example compressed air.

Cleaning should preferably be carried out at the end of the working shift before the machine is parked.

Use personal protective equipment such as protective goggles, gloves and respirator.

After cleaning, check and rectify any leaks. Close all covers and hoods.



## 326 Maintenance Maintenance service, when required

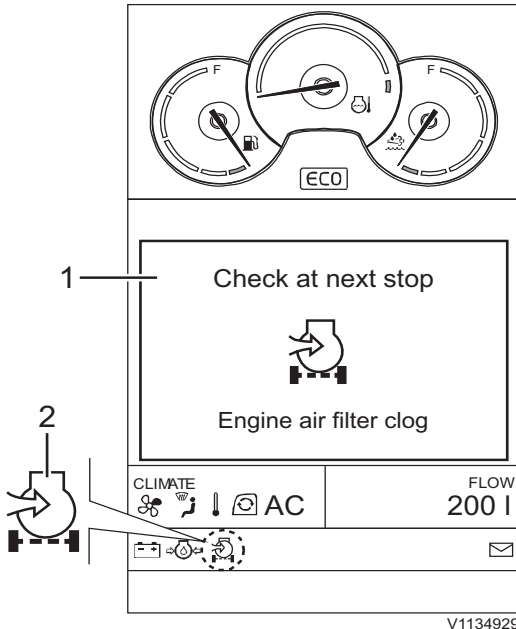

- 1 Check screen
- 2 Indicator

### Engine air cleaner

The air cleaner prevents dust and other impurities from entering the engine. The air first passes through the primary filter and then the secondary filter.

The degree of engine wear depends largely on the cleanliness of the induction air. Therefore, it is very important that the air cleaner should be checked regularly and maintained correctly. Observe great cleanliness when working with the air cleaner and filters.

### **NOTICE**

**Do not, under any circumstances, run the engine without a filter or with a damaged one. Always have a spare filter at hand and keep it well protected from dirt.**

Check regularly that hose and pipe connections from the air cleaner to the engine induction manifold do not leak.

### Engine air cleaner primary filter, cleaning and replacing

Clean the filter when the check screen for engine air filter clog pops up on the IC (Instrument Cluster). The filter may be cleaned, at the most, five times. Thereafter or after maximum 1 year, the filter should be replaced. Also replace the filter if it is damaged

Maintenance  
Maintenance service, when required **327**

---

**! WARNING**

Risk of hazardous inhalation.

Dangerous dust can lead to serious health problems.

**Always wear personal protective equipment, including filter mask, eye protection and appropriate gloves when handling and cleaning the engine compartment, coolers and air filters.**

**NOTICE**

**Risk of machine damage!**

Dust could enter the air intake system if the secondary filter comes off.

If the secondary filter comes off, clean the air cleaner housing thoroughly and make sure no dust enters the air intake system before reinstalling the secondary filter.

- Do not use compressed air.
- Vacuum cleaning is recommended, because it minimizes the risk that dust enters the air intake system.
- A wet cloth may be used but be careful not to push any dust into the air intake system.

**NOTE!**

Do not clean the filter if the check screen does not pop up on the IC (Instrument Cluster).

**NOTE!**

Use Volvo genuine air filters. Otherwise Volvo may not support the engine failures.

If the indicator is still alight after replacing or cleaning the primary filter, the secondary filter must be replaced.

As the length of time between filter replacements depends entirely on the operating environment of the machine, it may sometimes be necessary to replace the filter more often.

When cleaning the primary filter, mark it on the secondary filter to recognize primary cleaning times.

## Maintenance 328 Maintenance service, when required

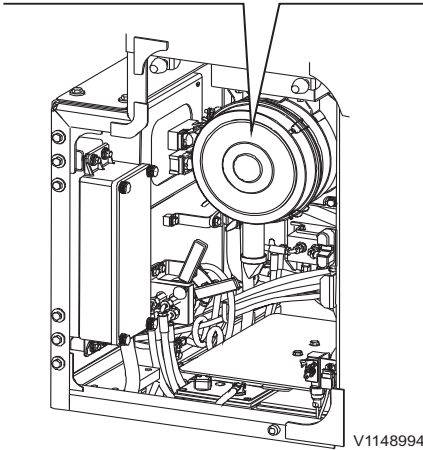
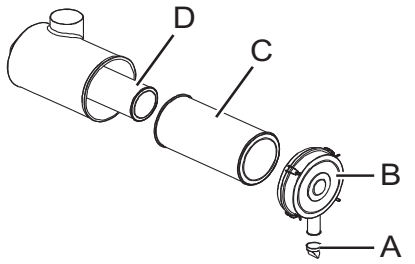

V1148994

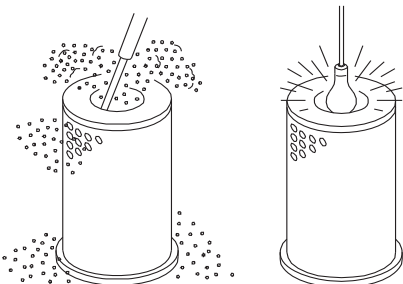

V1066003

### Mechanical cleaning

- 1 Open the cover.
- 2 Press with both thumbs on primary filter (C) at the same time as you pull it out. This is to prevent the secondary filter (D) from coming out together with the primary filter.
- 3 Carefully tap the end of the primary filter against a soft and clean surface.
- 4 Install the primary filter and the cover.

### NOTE!

Do not tap against a hard object.

### Cleaning with compressed air

- 1 Use clean and dry compressed air with a max. pressure of 500 kPa (5 bar) (73 psi). Do not hold the nozzle closer than 3 ~ 5 cm (1 ~ 2 in).
- 2 Blow the filter from the inside along the folds.
- 3 Check the filter with the aid of a lamp.
- 4 If there is the smallest hole, scratch, crack or other damage, the filter must be discarded.
- 5 Install the primary filter and the cover.

### NOTE!

To discover the damage more easily, this check should be made in a darkened room.

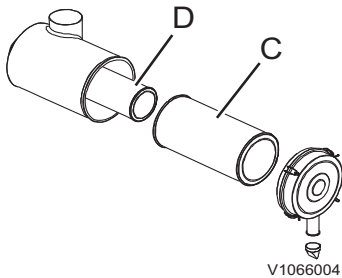

C Primary filter  
D Secondary filter

## Engine air cleaner secondary filter, replacing

Replace the secondary filter every 3rd time primary filter is replaced or at least every 2 years.

If the indicator is still alight even though the primary filter has been cleaned or replaced, the secondary filter should be replaced.

The secondary filter (D) works as a protective filter in case the primary filter (C) should be damaged.

### NOTE!

The secondary filter should not be removed or cleaned! It acts as a protective filter in case the primary filter is damaged and should be replaced by a qualified service technician at the specified service interval or when required.

### WARNING

Risk of hazardous inhalation.

Dangerous dust can lead to serious health problems.

**Always wear personal protective equipment, including filter mask, eye protection and appropriate gloves when handling and cleaning the engine compartment, coolers and air filters.**

### NOTICE

Risk of machine damage!

Dust could enter the air intake system if the secondary filter comes off.

If the secondary filter comes off, clean the air cleaner housing thoroughly and make sure no dust enters the air intake system before reinstalling the secondary filter.

- Do not use compressed air.
- Vacuum cleaning is recommended, because it minimizes the risk that dust enters the air intake system.
- A wet cloth may be used but be careful not to push any dust into the air intake system.

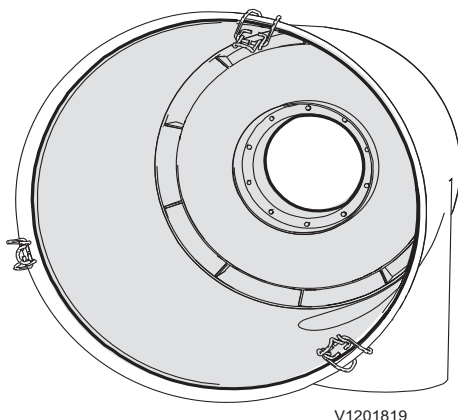

V1201819

Use vacuum cleaner to clean the air cleaner outlet.

### NOTICE

Take care of filters, oils and liquids in an environmentally safe way.

## 330 Maintenance Maintenance service, when required

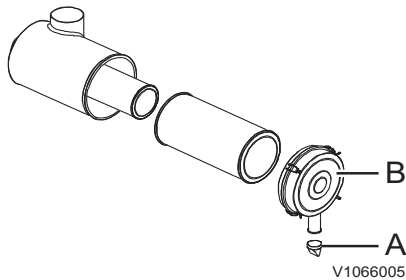

A Vacuator valve  
B Cover

### Engine air cleaner cover, cleaning

The cover for air cleaner should be cleaned when the primary filter is cleaned.

#### **WARNING**

Risk of hazardous inhalation.

Dangerous dust can lead to serious health problems.

**Always wear personal protective equipment, including filter mask, eye protection and appropriate gloves when handling and cleaning the engine compartment, coolers and air filters.**

- 1 Remove the cover (B) and valve (A) from the air cleaner.
- 2 Empty and clean the cover and valve.
- 3 Reinstall them on the air cleaner.

## Oil bath air cleaner, cleaning

See page 311.

## Radiator and coolers, cleaning

See page 303.

## Coolant level, checking

Check the coolant level when the warning screen for low coolant level pops up on the IC (Instrument Cluster), see page 43.

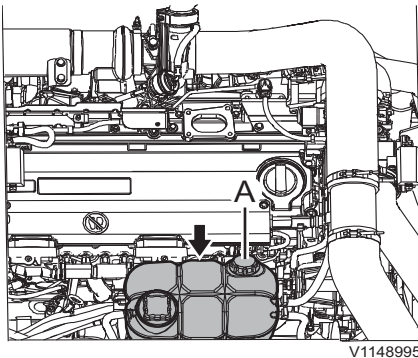

A Filler cap

### **WARNING**

Risk of scalding and severe burns to unprotected skin.

High-pressurised hot coolant may rush out of expansion tank and cause severe burns. Before removing the expansion tank pressure cap:

- Shut down the engine.
- Allow the engine to cool
- Turn the pressure cap slowly to release any pressure.

- 1 Position the machine on even, firm and level ground.
- 2 Open the engine hood.
- 3 Check the coolant level.

If the coolant level is lower than "MIN" marking on the tank, top up the coolant through filler cap between "MIN" and "MAX" level.

332 Maintenance  
Maintenance service, when required

## Track unit, adjusting tension

### **! WARNING**

Risk of serious injury  
Recoil spring cylinder is filled with pressurised grease. High pressure grease in the cylinder could cause serious injury or death.

**Always keep face, hands and body away from the grease nipple and valve when adjusting the track tension or loosening the track. Never remove the grease fitting or nut and valve assembly to release grease.**

#### Tightening track tension - reducing slack

- 1 Fill the grease through grease nipple (B) using a grease gun with high pressure.
- 2 Check the tension by moving the machine forward and rearward.
- 3 Check the tension again. If not correct, adjust it again.

#### Loosening track tension - increasing slack

- 1 Loosen the valve (A) gradually to drain the grease, but not more than one turn.  
If the grease does not drained smoothly, move the machine forward and rearward.

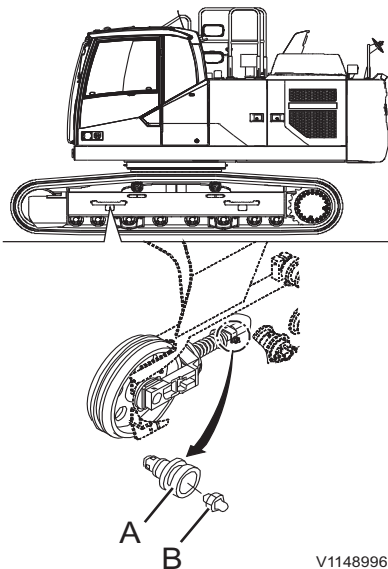

- A Valve  
B Grease nipple

### **NOTICE**

**Risk of environmental pollution!**

The grease in the track adjustment cylinder is under high pressure and large quantities of grease will be quickly released if the valve is loosened too much. Never loosen the valve by more than two turns when draining the grease.

- 2 Close the valve (A) but do not tighten excessively as the fitting may be damaged.
  - The valve (A) assembly, tightening torque: 7.0 kgf m (51 lbf ft) (69 N m)
- 3 Check the tension by moving the machine forward and rearward.
- 4 Check the tension again. If not correct, adjust it again.



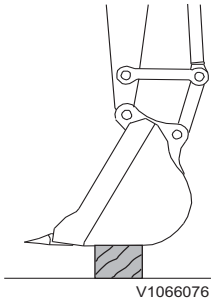

## Bucket teeth, replacing

Replace the bucket teeth before the adaptors wear away.

### WARNING

Risk of splinter injury.

When striking metal objects with a hammer, flying metal chips could cause serious splinter injury to eyes and other body parts.

**Always wear personal protective equipment and eye protection when replacing bucket teeth.**

- Lower the bucket to the ground and position it to the easiest posture for working.
- Stop the engine before replacing the bucket tooth.

### For side pin locking system

- 1 Lower the bucket horizontally and place it on a block.
- 2 Stop the engine and move the control lockout lever down to lock the system securely.
- 3 Drive out the pin (B) using a hammer and punch. Be careful not to damage the locking washer (C). Use a round bar with a smaller diameter than the pin as a punch.
- 4 Clean the surface of adapter (D) and insert a new locking washer (C) in the correct place, and then install a new tooth (A).
- 5 Drive the pin (B) into the pin groove until the pin is flush with the tooth.

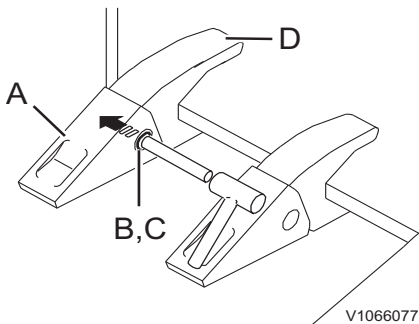



## 334 Maintenance Maintenance service, when required

### For Volvo tooth system I (VTS)

Replace the bucket teeth before the adaptors wear away.

#### WARNING

Risk of splinter injury.

Striking the bucket pin with a hammer could cause metal chips to fly around and cause serious splinter injury.

**Always wear face and eye protection, hard hat and gloves while removing and installing the bucket pins.**

A special tool may be ordered to facilitate replacement of teeth. The tool are available in different sizes depending on tooth size. Contact your dealer for further information.

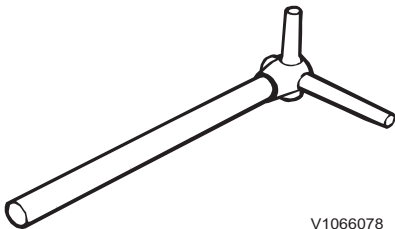

Special tool

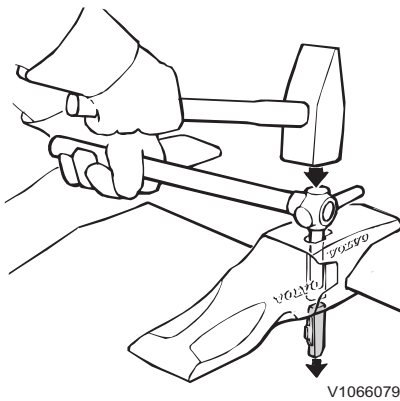

Knock out the locking device

#### Removing tooth

- 1 Lower the bucket horizontally on a block and angle it slightly upward.
- 2 Stop the engine and move the control lockout lever down to lock the system securely.
- 3 Clean the opening for tooth adapter locking device.
- 4 Knock out the locking device with a hammer and the tool or other suitable drift.
- 5 Remove tooth.

Maintenance  
Maintenance service, when required **335**

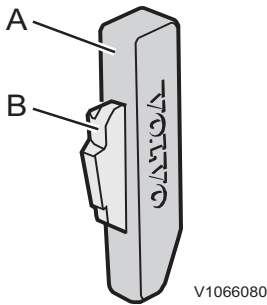

Locking device

- A Steel pin
- B Lock retainer

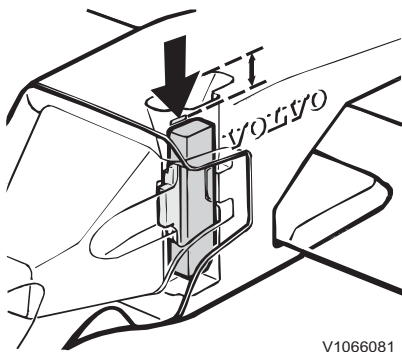

The locking device should be just below the scored line

### Installing tooth

- 1 Clean the front part of the tooth adapter and the hole for the locking device.
- 2 Install the tooth so that the guide lugs fit in the tooth adapter recesses.
- 3 Replace lock retainer (B) with a new part.
- 4 Install the locking device so that the chamfered part points downward and the lock retainer points forward.
- 5 Knock down the locking device with a hammer until it is level with the upper part of the tooth adapter.
- 6 Knock down the locking device further with a hammer and the tool or other suitable drift until the upper part is just below the scored line in the hole.

### NOTE!

Replace the steel pin in connection with replacement of tooth adapter.

## Bucket teeth, replacing

### For Volvo tooth system II (VTS)

A special tool may be ordered to facilitate replacement of teeth. The tool is available in different sizes depending on tooth size. Contact your dealer for more information.

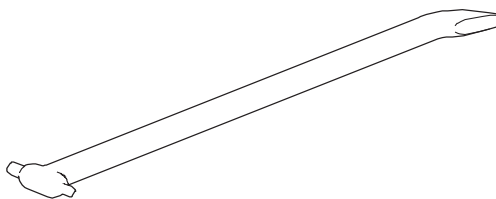

Special tool

### **WARNING**

**Risk of crushing by falling attachments. Hydraulic or mechanical failure may cause the attachments to fall, resulting in severe personal injury or death. Always support any attachment before adjusting or servicing it.**

### Removing tooth

- 1 Lower the bucket to the ground and angle it slightly upward.

## 336 Maintenance Maintenance service, when required

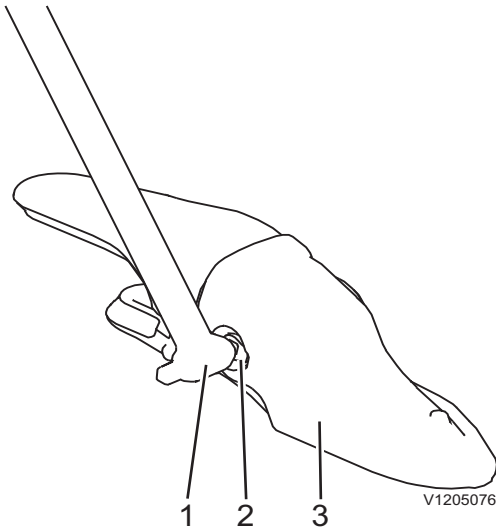

- 1 Special tool
- 2 Pin
- 3 Tooth

- 2 Clean the square hole in the pin.
- 3 Install the tool in the pin and turn it 90 degrees either way to unlock it.
- 4 Turn the tool back and forth, with an outwards motion, until the pin is removed. Use the pry bar end of the tool if the pin gets stuck.
- 5 Remove the tooth.

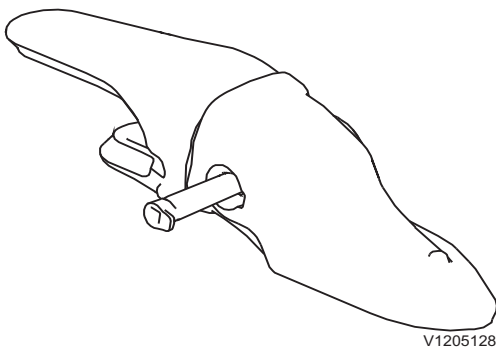

Tooth with pin

### Installing tooth

- 1 If changing the position of a tooth, check that the retainer is not bent or damaged.
- 2 Check that the pin is not bent or damaged.
- 3 Clean the front part of the adapter and the holes for the pin.
- 4 Place the tooth on the adapter.
- 5 Place the pin in the tooth. Check that the pin flange is aligned with the tooth.
- 6 Install the tool in the pin and turn it back and forth, with an inwards motion, until the pin is installed. A click sound will occur.
- 7 Check that the tooth is secured to the adapter.

## Hydraulic system, releasing pressure

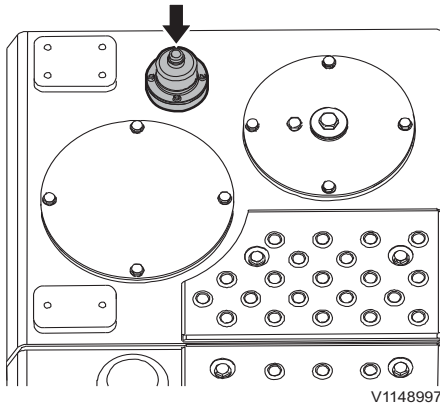

Breather on the hydraulic tank

### **WARNING**

Risk of high pressure injection.

Residual pressure in the hydraulic system could lead to oil under high pressure jetting out and cause serious injury, even if the engine has not been running for some time.

**Always release the pressure before any kind of service of the hydraulic system is carried out.**

Use the greatest caution when working on the hydraulic system. Remove system pressure and tank pressure:

- 1 Place attachment on the ground and shut down engine.
- 2 After engine is shut down, turn ignition switch to running position (Do not start engine).
- 3 Keep the control lockout lever up (unlocked position) and move all control levers and pedals to release main system pressure from all lines.
- 4 Turn ignition switch to OFF position, remove the key and tag the machine to indicate that the unit is under service.
- 5 Lower the control lockout lever (locked position).
- 6 Press the pressure relief valve located on the hydraulic tank breather valve to release tank pressure.

338 Maintenance  
Maintenance service, when required

## Accumulator, handling

### WARNING

Risk of serious injury.

Accumulators are charged with highly pressured nitrogen. Improper handling could lead to an explosion causing serious injury.

**Work on an accumulator must only be done by a qualified service technician.**

- Do not hit, drill or weld the accumulator.
- Keep it away from open flame or other highly heated sources.
- If you operate the operating lever downward just after the engine stops, the accumulator allows the attachment to move by its own weight.
- After releasing the pressure in accumulator, move the control lockout lever down to lock the system securely, see page 109.

### Accumulator, emergency operation

- 1 Stop the engine by turning the ignition switch to stop position.
- 2 Turn the ignition switch to operating position.
- 3 Move the control lockout lever up to unlock the system, see page 109.
- 4 Put the operating lever to boom down position to lower the attachment by its own weight.
- 5 Move the control lockout lever down to lock the system securely.

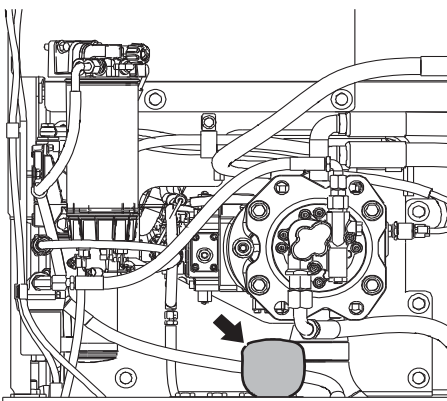

V1148998

Accumulator



### Accumulator, pressure releasing

- 1 Lower the attachment or load completely to the ground.
- 2 If using X1 or X3 axillary hydraulic circuit, do not activate.
- 3 After turning off the engine, turn the ignition switch to operating position.
- 4 Move the control lockout lever up to unlock the system.
- 5 To release the pressure in the control circuits and accumulator, move the operating levers and pedals forward / rearward and left / right to their respective end positions.
- 6 Turn the ignition switch to stop position.
- 7 Move the control lockout lever down to lock the system securely.



**340 Maintenance**  
**Maintenance service, when required**

**Recommended intervals for critical parts**

To ensure safety at all times when operating or driving the machine, periodic maintenance must always be carried out. To maintain safety over time, it is also recommended that periodic check or replacement of the parts given in the table below, is carried out. These parts are closely connected to safety and fire prevention. The material ages or materials are wearing with foreseeable deterioration. If these parts show any abnormality before the recommended interval has passed, they should be repaired or replaced immediately. If the hose clamps show any deterioration, such as deformation or cracking, replace the clamps at the same as the hoses. When replacing the hoses, always replace the O-rings, gaskets, and other related parts at the same time. The replacements should be carried out by a qualified service technician.

Inspection interval	Item
Daily	Fuel / hydraulic hoses - leakage of connections and end fittings
Monthly	Fuel / hydraulic hoses - leakage, damage of connections and end fittings
Yearly	Fuel / hydraulic hoses - leakage, damage, deformity and aging of connections and end fittings

Critical parts list for periodic replacement	Recommended interval
Fuel hoses	Every 2 years or 4000 hours, which occurs first
Hydraulic hoses	Every 6 years or 6000 hours, which occurs first
Seat belt	Every 3 years



### Maintenance under special environmental conditions

Conditions	Maintenance	Related page
Water or near the ocean	Before operating, check the tightness of plugs and all drain hoses and cocks.	-
	After working, replenish the grease to the attachment pins or the areas affected by the water.	<i>216</i>
	When operating the machine, make sure to check and lubricate attachment points affected by water regularly.	<i>290</i>
	After working near the ocean, clean the machine thoroughly with fresh water and service the electrical parts to prevent from corrosion. It is highly recommended to use dielectric grease in all harness connecting points for better sealing and to prevent corrosion.	-
Freezing weather	After working, fill up the fuel tank to prevent water from condensing in the tank.	<i>315</i>
	Use the recommended lubricants.	<i>343</i>
	Fully charge the batteries regularly, electrolyte may freeze. Ventilate well especially when the batteries are charged in a confined space.	<i>321</i>
	When storing machines in extremely cold temperature, remove batteries and store them at room temperature.	<i>193</i>
	Before parking, remove the mud and the dirt from the tracks.	-
Demolition work	Use fall protection over the cab against falling objects.	<i>218</i>
Low fuel quality	Drain the sediments in fuel tank at shorter service intervals. <sup>(1)</sup>	-
	Change the engine oil and engine oil filter at shorter service intervals. <sup>(1)</sup>	-

1. Contact a workshop authorized by Volvo





**342 Maintenance**  
**Maintenance service, when required**

Dusty atmosphere	Check regularly that hose and pipe connections from the air cleaner to the engine induction manifold do not leak.	326
	Clean the air filter at shorter service intervals.	326
	Clean the clogging net for radiator and oil cooler at shorter service intervals.	331
	Clean the areas on the machine where dust, chips and similar may collect at shorter service intervals in order to minimize the risk of fire.	323
	Pay attention to and clean the engine compartment and surrounding areas regularly.	325
Rocky ground	Use a suitable track for the ground conditions. If in doubt, contact your closest Volvo dealer for proper advice.	251
	Use a suitable attachment for the ground conditions such as a heavy duty bucket. <sup>(1)</sup>	-
Hammer operation	Change the hydraulic oil and return filter of hammer circuit at shorter service intervals. <sup>(1)</sup>	-

1. Contact a workshop authorized by Volvo



## Specifications Recommended lubricants

### Recommended lubricants

The Volvo lubricants have been specially developed to fulfil the demanding operating conditions, in which Volvo excavators are used in. The oils have been tested according to Volvo excavator specifications and therefore meet the high requirements for safety and quality. Other mineral oils can be used if they conform to our viscosity recommendations and meet our quality requirements. The approval of Volvo is required, if any other oil base quality (for example biologically degradable oil) is to be used.

System	Oil grade	Recommended viscosity at varying ambient temperature																																								
Engine	Engine oil For detail, see page 346.	<table border="1" style="width: 100%; border-collapse: collapse;"> <tr> <td>°C</td> <td>-30</td> <td>-20</td> <td>-10</td> <td>0</td> <td>+10</td> <td>+20</td> <td>+30</td> <td>+40</td> <td>+50</td> </tr> <tr> <td>°F</td> <td>-22</td> <td>-4</td> <td>-14</td> <td>+32</td> <td>+50</td> <td>+68</td> <td>+86</td> <td>+104</td> <td>+122</td> </tr> <tr> <td colspan="10" style="text-align: center;"> </td> </tr> </table>	°C	-30	-20	-10	0	+10	+20	+30	+40	+50	°F	-22	-4	-14	+32	+50	+68	+86	+104	+122																				
°C	-30	-20	-10	0	+10	+20	+30	+40	+50																																	
°F	-22	-4	-14	+32	+50	+68	+86	+104	+122																																	
Fuel	Diesel fuel For detail, see page 350.	<table border="1" style="width: 100%; border-collapse: collapse;"> <tr> <td>°C</td> <td>-30</td> <td>-20</td> <td>-10</td> <td>0</td> <td>+10</td> <td>+20</td> <td>+30</td> <td>+40</td> <td>+50</td> </tr> <tr> <td>°F</td> <td>-22</td> <td>-4</td> <td>-14</td> <td>+32</td> <td>+50</td> <td>+68</td> <td>+86</td> <td>+104</td> <td>+122</td> </tr> <tr> <td colspan="10" style="text-align: center;"> </td> </tr> <tr> <td colspan="10"> <p><b>NOTE!</b> The fuel should at least meet the legal requirement, and national and international standards for marketed fuels, for example : EN590 (with nationally adapted temperature requirements), ASTM D975 No 1-D and No 2-D, JIS KK 2204.</p> </td> </tr> </table>	°C	-30	-20	-10	0	+10	+20	+30	+40	+50	°F	-22	-4	-14	+32	+50	+68	+86	+104	+122											<p><b>NOTE!</b> The fuel should at least meet the legal requirement, and national and international standards for marketed fuels, for example : EN590 (with nationally adapted temperature requirements), ASTM D975 No 1-D and No 2-D, JIS KK 2204.</p>									
°C	-30	-20	-10	0	+10	+20	+30	+40	+50																																	
°F	-22	-4	-14	+32	+50	+68	+86	+104	+122																																	
<p><b>NOTE!</b> The fuel should at least meet the legal requirement, and national and international standards for marketed fuels, for example : EN590 (with nationally adapted temperature requirements), ASTM D975 No 1-D and No 2-D, JIS KK 2204.</p>																																										
Cooling system	<b>Volvo Coolant VCS Ready Mixed</b> For detail, see page 347.	<p><b>Volvo Coolant VCS Ready Mixed</b> should be used only.</p> <p><b>NOTE!</b> The content of Volvo coolant must not be less than 40% of the total mixture.</p>																																								

\*: Installed at factory

\*\*\*: VDS-4 or VDS-4.5 approved oils only. Other oils can be used up to +30°C (86°F).



344 Specifications  
Recommended lubricants

System	Oil grade	Recommended viscosity at varying ambient temperature																																																	
Hydraulic system	Hydraulic oil for severe cold area or if siberian option kit is installed	<table border="1"> <tr> <td>°C</td> <td>-30</td> <td>-20</td> <td>-10</td> <td>0</td> <td>+10</td> <td>+20</td> <td>+30</td> <td>+40</td> <td>+50</td> </tr> <tr> <td>°F</td> <td>-22</td> <td>-4</td> <td>-14</td> <td>+32</td> <td>+50</td> <td>+68</td> <td>+86</td> <td>+104</td> <td>+122</td> </tr> <tr> <td></td> <td colspan="9" style="text-align: center;">ISO VG15</td> </tr> </table>	°C	-30	-20	-10	0	+10	+20	+30	+40	+50	°F	-22	-4	-14	+32	+50	+68	+86	+104	+122		ISO VG15																											
	°C	-30	-20	-10	0	+10	+20	+30	+40	+50																																									
	°F	-22	-4	-14	+32	+50	+68	+86	+104	+122																																									
		ISO VG15																																																	
Volvo Hydraulic Oil Volvo 98609 Extra 46 or Volvo Hydraulic Oil Volvo 98609 Extra 68	<table border="1"> <tr> <td>°C</td> <td>-30</td> <td>-20</td> <td>-10</td> <td>0</td> <td>+10</td> <td>+20</td> <td>+30</td> <td>+40</td> <td>+50</td> </tr> <tr> <td>°F</td> <td>-22</td> <td>-4</td> <td>-14</td> <td>+32</td> <td>+50</td> <td>+68</td> <td>+86</td> <td>+104</td> <td>+122</td> </tr> <tr> <td></td> <td colspan="9" style="text-align: center;">ISO VG32 HV</td> </tr> <tr> <td></td> <td colspan="9" style="text-align: center;">ISO VG46 HV</td> </tr> <tr> <td></td> <td colspan="9" style="text-align: center;">ISO VG68 HV</td> </tr> </table>	°C	-30	-20	-10	0	+10	+20	+30	+40	+50	°F	-22	-4	-14	+32	+50	+68	+86	+104	+122		ISO VG32 HV										ISO VG46 HV										ISO VG68 HV								
°C	-30	-20	-10	0	+10	+20	+30	+40	+50																																										
°F	-22	-4	-14	+32	+50	+68	+86	+104	+122																																										
	ISO VG32 HV																																																		
	ISO VG46 HV																																																		
	ISO VG68 HV																																																		
Volvo Hydraulic Oil Volvo 98610 Biodegradable 46	<table border="1"> <tr> <td>°C</td> <td>-30</td> <td>-20</td> <td>-10</td> <td>0</td> <td>+10</td> <td>+20</td> <td>+30</td> <td>+40</td> <td>+50</td> </tr> <tr> <td>°F</td> <td>-22</td> <td>-4</td> <td>-14</td> <td>+32</td> <td>+50</td> <td>+68</td> <td>+86</td> <td>+104</td> <td>+122</td> </tr> <tr> <td></td> <td colspan="9" style="text-align: center;">Bio oil VG46</td> </tr> </table> <p><b>NOTE!</b> If the machine is filled with Volvo Biodegradable hydraulic oil this oil must also be used when filling and changing. The mineral oil content in bio oil should not exceed 2% when changing from mineral oil to bio oil. Contact a workshop authorised by Volvo.</p>	°C	-30	-20	-10	0	+10	+20	+30	+40	+50	°F	-22	-4	-14	+32	+50	+68	+86	+104	+122		Bio oil VG46																												
°C	-30	-20	-10	0	+10	+20	+30	+40	+50																																										
°F	-22	-4	-14	+32	+50	+68	+86	+104	+122																																										
	Bio oil VG46																																																		
Volvo Hydraulic Oil Volvo 98620 Ultra 46 or Volvo Hydraulic Oil Volvo 98620 Ultra 68	<table border="1"> <tr> <td>°C</td> <td>-30</td> <td>-20</td> <td>-10</td> <td>0</td> <td>+10</td> <td>+20</td> <td>+30</td> <td>+40</td> <td>+50</td> </tr> <tr> <td>°F</td> <td>-22</td> <td>-4</td> <td>-14</td> <td>+32</td> <td>+50</td> <td>+68</td> <td>+86</td> <td>+104</td> <td>+122</td> </tr> <tr> <td></td> <td colspan="9" style="text-align: center;">ISO VG32</td> </tr> <tr> <td></td> <td colspan="9" style="text-align: center;">ISO VG46</td> </tr> <tr> <td></td> <td colspan="9" style="text-align: center;">ISO VG68</td> </tr> </table>	°C	-30	-20	-10	0	+10	+20	+30	+40	+50	°F	-22	-4	-14	+32	+50	+68	+86	+104	+122		ISO VG32										ISO VG46										ISO VG68								
°C	-30	-20	-10	0	+10	+20	+30	+40	+50																																										
°F	-22	-4	-14	+32	+50	+68	+86	+104	+122																																										
	ISO VG32																																																		
	ISO VG46																																																		
	ISO VG68																																																		



Specifications  
**Recommended lubricants 345**

System	Oil grade	Recommended viscosity at varying ambient temperature																														
Track gearbox	Volvo Axle Oil 80W-90 GL-5 or	<table border="1" style="width: 100%; text-align: center;"> <tr> <td>°C</td> <td>-30</td> <td>-20</td> <td>-10</td> <td>0</td> <td>+10</td> <td>+20</td> <td>+30</td> <td>+40</td> <td>+50</td> </tr> <tr> <td>°F</td> <td>-22</td> <td>-4</td> <td>-14</td> <td>+32</td> <td>+50</td> <td>+68</td> <td>+86</td> <td>+104</td> <td>+122</td> </tr> <tr> <td colspan="10"> <div style="display: flex; justify-content: space-around; align-items: center;"> <div style="border: 1px solid black; background-color: #cccccc; padding: 2px;">*SAE 90</div> <div style="border: 1px solid black; background-color: #cccccc; padding: 2px;">SAE 140</div> </div> </td> </tr> </table> <p>Or corresponding gearbox oil below.</p> <ul style="list-style-type: none"> <li>- Mobil SHC630</li> <li>- Chevron Cetus HiPerSYN Oil 220</li> </ul>	°C	-30	-20	-10	0	+10	+20	+30	+40	+50	°F	-22	-4	-14	+32	+50	+68	+86	+104	+122	<div style="display: flex; justify-content: space-around; align-items: center;"> <div style="border: 1px solid black; background-color: #cccccc; padding: 2px;">*SAE 90</div> <div style="border: 1px solid black; background-color: #cccccc; padding: 2px;">SAE 140</div> </div>									
°C	-30		-20	-10	0	+10	+20	+30	+40	+50																						
°F	-22		-4	-14	+32	+50	+68	+86	+104	+122																						
<div style="display: flex; justify-content: space-around; align-items: center;"> <div style="border: 1px solid black; background-color: #cccccc; padding: 2px;">*SAE 90</div> <div style="border: 1px solid black; background-color: #cccccc; padding: 2px;">SAE 140</div> </div>																																
Swing gearbox	Volvo Axle Oil 85W-140 GL-5 or																															
PTO gearbox (EC950E only)	Volvo Axle Oil Volvo 97317 75W-80 GO102 or Volvo Axle Oil Limited Slip 85W-90 GL-5																															
Swing ring gear (Bath and Ball)	Volvo Lithium Grease EP2	<table border="1" style="width: 100%; text-align: center;"> <tr> <td>°C</td> <td>-30</td> <td>-20</td> <td>-10</td> <td>0</td> <td>+10</td> <td>+20</td> <td>+30</td> <td>+40</td> <td>+50</td> </tr> <tr> <td>°F</td> <td>-22</td> <td>-4</td> <td>-14</td> <td>+32</td> <td>+50</td> <td>+68</td> <td>+86</td> <td>+104</td> <td>+122</td> </tr> <tr> <td colspan="10"> <div style="border: 1px solid black; background-color: #cccccc; padding: 2px;">Multi purpose EP** grease NLGI 2</div> </td> </tr> </table> <p>Or corresponding grease on lithium base with EP** additives and consistency NLGI class 2.</p>	°C	-30	-20	-10	0	+10	+20	+30	+40	+50	°F	-22	-4	-14	+32	+50	+68	+86	+104	+122	<div style="border: 1px solid black; background-color: #cccccc; padding: 2px;">Multi purpose EP** grease NLGI 2</div>									
°C	-30	-20	-10	0	+10	+20	+30	+40	+50																							
°F	-22	-4	-14	+32	+50	+68	+86	+104	+122																							
<div style="border: 1px solid black; background-color: #cccccc; padding: 2px;">Multi purpose EP** grease NLGI 2</div>																																
Pin and bushing	Ultra Grease Moly EP2 or Volvo Lithium Grease EP2 <sup>(a)</sup> For detail, see page 349.	<table border="1" style="width: 100%; text-align: center;"> <tr> <td>°C</td> <td>-30</td> <td>-20</td> <td>-10</td> <td>0</td> <td>+10</td> <td>+20</td> <td>+30</td> <td>+40</td> <td>+50</td> </tr> <tr> <td>°F</td> <td>-22</td> <td>-4</td> <td>-14</td> <td>+32</td> <td>+50</td> <td>+68</td> <td>+86</td> <td>+104</td> <td>+122</td> </tr> <tr> <td colspan="10"> <div style="border: 1px solid black; background-color: #cccccc; padding: 2px;">*ISO-L-XBCFB2</div> </td> </tr> </table> <p>Or corresponding grease on lithium base with EP** additives and consistency NLGI class 2.</p>	°C	-30	-20	-10	0	+10	+20	+30	+40	+50	°F	-22	-4	-14	+32	+50	+68	+86	+104	+122	<div style="border: 1px solid black; background-color: #cccccc; padding: 2px;">*ISO-L-XBCFB2</div>									
°C	-30	-20	-10	0	+10	+20	+30	+40	+50																							
°F	-22	-4	-14	+32	+50	+68	+86	+104	+122																							
<div style="border: 1px solid black; background-color: #cccccc; padding: 2px;">*ISO-L-XBCFB2</div>																																
Air conditioner system	Refrigerant	HFC R134a																														

a) Volvo Lithium Grease EP2 is not recommended when the ambient temperature is above 40 °C.

\*: Installed at factory

\*\* : Extreme Pressure



346 Specifications  
Recommended lubricants

### Engine oil

Follow recommended change intervals according to the oil's grade and sulphur content in the fuel.

Oil grade	Sulphur content in the fuel, ppm (10000 ppm = 1%)				
	< 15	15 - 500	500 - 3000	3000 - 5000	> 5000
Oil change interval					
Volvo Engine Oil VDS-4.5 10W-30 or Volvo Engine Oil VDS-4.5 15W-40 or Other approved VDS-4.5 oil	500 hours	Not applicable			
Volvo Engine Oil VDS-4 10W-30 or Volvo Engine Oil VDS-4 15W-40 or Other approved VDS-4 oil					
ACEA: E9	250 hours	Not applicable			
API: CJ-4 or CK-4					

- ACEA: European Automobile Manufacturers Association
- API: American Petroleum Institute



## Coolant

Only use Volvo Coolant VCS when topping up or changing coolant. To avoid damage to engine and cooling system, different coolants or corrosion protection must not be mixed. When using concentrated Volvo Coolant VCS and clean water, the mixture should contain 40–60% concentrated coolant and 60–40% clean water. The amount of concentrated coolant must never be less than 40% of the total mixture, see table below.

Freeze protection down to	Mixed-in amount of concentrated coolant
-25 °C (-13 °F)	40%
-35 °C (-31 °F)	50%
-46 °C (-51 °F)	60%

The concentrated coolant must not be mixed with water that contains a high degree of lime (hard water), salt or metals.

**The clean water for the cooling system must also meet the following requirements:**

Description	Value
Total number of solid particles	< 340 ppm
Total hardness	< 9.5° dH
Chloride	< 40 ppm
Sulphate	< 100 ppm
pH value	5.5-9
Silica	< 20 mg SiO <sub>2</sub> /litre
Iron	< 0.10 mg Fe/litre
Manganese	< 0.05 mg Mn/litre
Electrical conductivity	< 500 µS/cm
Organic material, COD-Mn	< 15 mg/litre

If there is any doubt about the water quality, use ready-mixed Volvo Coolant VCS, which contains 40% concentrated coolant. Do not mix with any other ready-mixed coolants since this may result in engine damage.



348 Specifications  
Recommended lubricants

### Hydraulic oil

Only use Volvo genuine hydraulic oil approved by Volvo Construction Equipment must be used. Do not mix different brands of hydraulic oil as this can lead to damage in the hydraulic system.

For the hydraulic oil specification, see page 343.

	Ambient temperature											
	°C	-40	-30	-20	-10	0	+10	+20	+30	+40	+50	+60
	°F	-40	-22	-4	+14	+32	+50	+68	+86	+104	+122	+140
Oil grade		(B)		(A)				(C)				
			(B)		(A)				(C)			
				(B)		(A)						

(A) : Ambient temperature recommended for general use of hydraulic system and components.

(B) : Ambient temperature guide for machine operation from a hydraulic oil viewpoint only, it does not guarantee the completion machine for other conditions like engine starting performance. In this range a warming-up period is needed to obtain proper performance.

(C) : Ambient temperature range to operate machine under special conditions, not a recommendation for general use conditions.

**Additional recommendation for severe cold areas**

A field solution for severe cold condition of ambient temperature between -40°C and +20°C.

- Type : Anti-wear type hydraulic oil
- Viscosity characteristic

Viscosity index : More than 130

Kinematic Viscosity : Less than 5,000cSt at -40°C, More than 5.6cSt at +90°C

**NOTE!**

This value is approximately equivalent to ISO Viscosity grade #22.

**NOTE!**

It is minimum theoretical recommendation without the guarantee of machine condition.



## Grease

Recommended grease for all digging equipment greasing points

Manufacturer	Product name	
	Recommendations	Alternatives*
<b>VOLVO</b>	Ultra Grease Moly EP2	Volvo Lithium Grease EP2
<b>CALTEX</b>	Molytex EP2	Multifak EP2
<b>GULF</b>	Gulflex Moly EP	Gulfcrown EP2
<b>EXXONMOBIL</b>	Beacon EP2 Moly	Beacon EP2
<b>SHELL</b>	Retinax HDX2 / Alvania HDX2	Retinax EP2 / Alvania EP2
<b>TOTAL</b>	Multis MS2	Multis EP2
<b>CASTROL</b>	Pyro LM	Pyroplex Red

\* Alternatives are not recommended when the ambient temperature is above 40 °C.

### Mixability of types of grease with different additives

	Mixability of types of grease with additives					
	Lithium	Calcium	Lithium complex	Calcium complex	Aluminium complex	Clay
<b>Lithium</b>	√	√	√			
<b>Calcium</b>	√	√	√			√
<b>Lithium complex</b>	√	√	√	√		
<b>Calcium complex</b>			√	√		
<b>Aluminium complex</b>			√		√	
<b>Clay</b>		√			√	√

√ : Acceptable



## Fuel system

### Fuel

#### Fuel quality requirements

The fuel should at least meet the legal requirements, national and international standards for marketed fuels, for example: EN590 (with nationally adapted temperature requirements), ASTM D 975 No. 1D and 2D, JIS KK 2204. Fuel specification varies according to the working temperature. Please contact authorized Volvo dealer.

#### Sulphur content

According to current USA legal requirement, the sulphur content in the diesel fuel must not exceed 0.0015 percent (15 ppm) by weight.

According to current EU/other countries legal requirements, the sulphur content in the diesel fuel must not exceed 0.001 percent (10 ppm) by weight.

#### Bio-diesel fuel

Vegetable oils and / or esters, also called "bio-diesel", (e.g. rape-seed methyl ester RME fuel), which are offered on certain markets both as pure products and as mixed into the diesel fuel.

Volvo Construction Equipment accepts a maximum intermix of 7% bio-diesel fuel in the diesel fuel, ready mixed from the oil companies. A higher intermix than 7% of bio-diesel fuel may cause:

- Increased emission by nitrogen oxide, (thereby not meeting legal requirements)
- Shorter service life of engine and injection system
- Increased fuel consumption
- Altered engine output
- Shortening the engine oil change interval to a half
- Shortened service life of rubber materials in the fuel system
- Less good cold handling properties of the fuel
- Limit storage time for the fuel, which may cause clogging up of the fuel system if the machine is laid up for longer periods

#### Warranty condition

The warranty does not cover damage caused by an intermix of more than 7% of bio-diesel fuel.

### Alternative fuels

**This statement is only valid for Volvo branded engines.**

Hydro-treated vegetable oil (HVO) and fatty acid methyl ester (FAME) biodiesel are both made from renewable raw materials such as vegetable oils and animal fats, but they are chemically processed in different ways.



### Hydro-treated vegetable oil (HVO)

HVO is created using a chemical process called hydro-treating. Hydro-treating creates an oxygen-free hydrocarbon product that is very similar to distillate diesel fuel and is well suited for use in diesel engines. HVO fuels complying with the CEN diesel fuel standard EN 590:2013 or with the European Fuel Quality Directive 98/70/EC are approved for use in all Volvo Construction Equipment diesel engines with no changes to maintenance intervals. Paraffinic diesel fuels complying with the CEN standard EN 15940 may be used in all machines operating outside the European Union and for EU-certified engines up to the emission level Stage IV. These fuels may also be used for the EU-certified D11, D13 and D16 engines meeting the emission level Stage V.

### Biodiesel

Biodiesel is a product made from renewable resources such as vegetable oils or animal fat. Biodiesel that has been chemically processed into fatty acid methyl ester (FAME) can be blended with distillate diesel fuel and used in some diesel engines. Unblended biodiesel is referred to as B100 because it is 100% biodiesel.

Rapeseed methyl ester (RME) is the most common type of FAME used in Europe. Soy methyl ester (SME) and sunflower oil methyl ester (SOME) are the most common types of FAME used in the US. Although use of FAME biodiesel is now a legal requirement in some markets, it is not as suitable for use in diesel engines as conventional diesel fuel or HVO (hydro-treated vegetable oil).

### Biodiesel fuel requirements

The FAME biodiesel blends specified in the table below are approved for use if:

- The biodiesel is pre-blended by the fuel supplier
- The biodiesel used in the blend conforms to EN14214 or ASTM D6751
- The distillate fuel used in the blend meets fuel sulphur requirements
- The distillate fuel used in the blend conforms to EN590 or ASTM D975
- B1-B5 biodiesel blends conform to EN590 or ASTM D975
- B6-B7 biodiesel blends conform to EN590 or ASTM D7467



**352**      Specifications  
**Fuel system**

- B8-B20 biodiesel blends conform to EN16709(B20) or ASTM D7467

Engine emission designation	Engine size	Acceptable blend
EU Stage II / US Tier 2 * EU Stage IIIA / US Tier 3 * EU Stage IIIB / US Tier 4 interim EU Stage IV / US Tier 4 final EU Stage V	Below D4 / 4 litres	Up to B7
EU Stage II / US Tier 2 * EU Stage IIIA / US Tier 3 * EU Stage IIIB / US Tier 4 interim EU Stage IV / US Tier 4 final	D4–D8	Up to B7
EU Stage II / US Tier 2 * EU Stage IIIA / US Tier 3 * US Tier 4 final, special North America arrangement **	D9–D16	Up to B20
EU Stage IIIB / US Tier 4 interim EU Stage IV / US Tier 4 final	D11–D16	Up to B10
EU Stage IIIB / US Tier 4 interim, equipped with High Sulphur Fuel Conversion Kit (only available in unregulated markets) EU Stage IV / US Tier 4 final, equipped with High Sulphur Fuel Conversion Kit (only available in unregulated markets)	D4–D16	Up to B20



Specifications  
**Fuel system**      **353**

Engine emission designation	Engine size	Acceptable blend
EU Stage V	D4–D16	Up to B7
<p>* As Tier 2 and Tier 3 emissions regulations ended in 2005 and 2010 respectively, engines produced since then typically <b>meet Stage II / Stage IIIA regulations</b>, allowing their sale in less regulated markets.</p> <p>** With additional restrictions and special operating conditions, equipment used in North America may operate on B20 diesel.</p>		

**NOTE!**

Failures directly caused by the use of poor quality biofuel, or any other fuel not conforming to standards, are not factory defects and the manufacturer’s warranty does not apply.

**Maintenance interval requirements**

Additional service actions and shorter maintenance intervals are mandatory when using biodiesel blends above B10.

<b>Every 10 hours</b>
<ul style="list-style-type: none"> <li>- Check the engine oil and change if it rises above the maximum fill level</li> <li>- Inspect the fuel system components and replace as necessary</li> </ul>
<b>Half of original interval</b>
<ul style="list-style-type: none"> <li>- Change the engine oil and filter</li> <li>- Replace the fuel filter(s)</li> </ul>
<b>Every year, regardless of operating hours</b>
<ul style="list-style-type: none"> <li>- Change the engine oil and filter</li> <li>- Clean the fuel tank</li> </ul>

**Effects of biodiesel on engine oil**

Using biodiesel can lead to increased oil dilution. Use engine oil analysis tools frequently to check for fuel dilution and monitor engine oil condition. Check the engine oil level daily. Always change the engine oil if the oil level rises above the maximum fill level.

**Effects of biodiesel on fuel systems**

Biodiesel dissolves and loosens some fuel system deposits. During the initial conversion to biodiesel, loosened deposits will travel to the fuel filters and require more frequent fuel filter replacements. Start with new fuel filters when using biodiesel for the first time.



Biodiesel is aggressive to some materials used in fuel system components. Inspect seals, hoses, rubber and plastic components every 10 hours. Repair or replace any components that are damaged, softened or leaking. Clean biodiesel from painted surfaces immediately to prevent paint damage.

Biodiesel is more sensitive to bacteria and water contamination than distillate diesel fuel.

- Use as much fuel as possible before refilling the fuel tank in order to prevent bacteria growth if a machine is in regular use, e.g. regularly uses up a tank of fuel within a week. In climates where condensation is a risk, or when the machine is working for short durations, keep the fuel tank full.
- Do not use biodiesel in machines with low utilization or operating time.
- Do not store machines for more than 4 weeks without flushing biodiesel out of the fuel system by operating the machine through at least one full tank of distillate diesel fuel.
- Always follow the manufacturer's storage recommendations and "best-before" dates for each delivery of biodiesel.

#### **Effects of biodiesel on exhaust aftertreatment systems**

Biodiesel leaves higher levels of ash in diesel particulate filters and may require more frequent diesel particulate filter (DPF) regeneration and cleaning. Biodiesel can cause deviations in temperatures and functionality of the DPF burner and may cause fault codes or errors.

Biodiesel exhaust gas is aggressive to some materials used in selective catalytic reduction systems (SCR) and may require more frequent cleaning, repairing or replacing of SCR parts.

#### **Effects of biodiesel on cold weather operation**

Biodiesel has a high viscosity at temperatures below 0 °C (32 °F) and may cause problems starting the engine. Use a fuel heater or park machines in a heated building if possible.

#### **Effects of biodiesel on engine performance**

Biodiesel B100 has about 8% lower energy density compared to regular diesel fuel. Blends equal or lower than B20 have a small impact on engine performance.

**Effects of biodiesel on emissions compliance**

Engines are certified to comply with U.S. EPA, California and EU emissions standards based upon the use of test fuels with specifications established by these regulatory agencies. Alternative fuels, including biodiesel, that are not substantially similar to the required test fuels may adversely affect engine emissions compliance. As a result, Volvo does not warrant that the engine will conform to applicable Federal or California and EU emissions limits when operated on, or having previously being operated on, biodiesel or other alternative fuels that are not substantially similar to specified test fuels used for certification, nor if biodiesel / regular diesel is used in blends that exceed the recommendations.

However, the use of biodiesel up to a maximum of 20% (B20) in and of itself, will not affect the manufacturer's mechanical warranty as to engine or emissions system, provided the bio fuel used in the blend conforms to the applicable standards and the additional steps outlined herein are followed.



## 356 Specifications Fuel system

---

### AdBlue®/DEF

#### **NOTICE**

**Risk of machine damage.**

In the short term, use of the wrong fluid can lead to reduced engine power. In the long term, it can lead to damage to the SCR-system and the catalyst. Reusing AdBlue®/DEF can lead to contamination. Damages caused by the use of incorrect fluids will not be covered by the warranty.

**Always use fluid specified in ISO 22241-1. Do not reuse drained AdBlue®/DEF.**

For reducing nitrogen oxides (NO<sub>x</sub>) the engine is equipped with a selective catalytic reduction (SCR) system. A diesel exhaust fluid is needed for the process to work. The fluid is called AdBlue® in Europe and Asia, but in North America it is called Diesel Exhaust Fluid (DEF). When needed, the SCR system warms up the AdBlue®/DEF-tank and lines.

The fluid is filled in a separate tank, which is completely separated from the fuel tank. AdBlue®/DEF may not be mixed in the fuel tank and fuel may not be mixed in the AdBlue®/DEF-tank.

AdBlue®/DEF consists of urea crystals (32.5%) and distilled water (67.5%). It is transparent, clear, and has a slight odour of ammonia. The fluid is not considered to be hazardous, but should still be handled with care. It is very corrosive, especially with copper and aluminium. For this reason, avoid spilling the fluid on electric cables and components. Always wipe up any spilled AdBlue®/DEF.

AdBlue®/DEF is not a combustible product. When exposed to high temperatures it will convert to ammonia and carbon dioxide. The fluid should not come into contact with other chemicals or be mixed with other chemicals.

AdBlue®/DEF is sensitive to both high and low temperatures. It should not be exposed to direct sunlight for any extended period of time. If the machine is not in use, AdBlue®/DEF starts to freeze at -11 °C (12 °F). The fluid volume in the tank increases when frozen, this is why it is important to follow the recommended fill volume. AdBlue®/DEF does not break down or degrade when it freezes. The SCR-system will thaw the fluid so that it regains its concentration with maintained quality. The machine will work normally during the time that the fluid melts.

At AdBlue®/DEF temperatures above 20 °C (68 °F) the fluid starts to degrade. Then the fluid gives off ammonia, which is aggressive to materials such as rubber. At temperatures above 75–80 °C (167–176 °F), ammonia production increases. However, high temperatures are permitted for a short time.

AdBlue®/DEF should be stored in a cool, dry, and ventilated place. The fluid may not be stored in direct sunlight. The recommended storage temperature for AdBlue®/DEF is between -11 °C (12 °F) and 25 °C (77 °F). Under these conditions, storage life is approx. two years. Long-term storage of AdBlue®/DEF at a temperature above 25 °C (77 °F) can reduce the lifetime of the fluid. A short time exposure to higher temperatures has no impact on the quality.

**NOTE!**

If the machine is to be parked for an extended period of time (several months) in ambient temperatures above 40 °C (104 °F) the tank must be drained. This to prevent the fluid from having the wrong quality when starting the machine or that precipitates have a negative impact on the component parts.

**NOTE!**

If the tank has been drained completely it should be rinsed out with new AdBlue®/DEF before new fluid is filled. Never reuse old fluid. If distilled water or ordinary water is used when rinsing there is a risk that the system will generate an alarm due to wrong quality of AdBlue®/DEF.

**NOTE!**

Water of any kind should not be used when cleaning AdBlue®/DEF system or AdBlue®/DEF components since there is a risk that even a small amount of water remains in the system after cleaning. The only exceptions allowed are operations described in the service information made by Volvo.

AdBlue®/DEF is available in plastic container, barrel, IBC, or bulk.

For information on ordering AdBlue®/DEF (only applies to USA-market):

- Volvo Construction Equipment: 1-877-823-1111 (office hours)
- [www.volvoce.com](http://www.volvoce.com) (outside of office hours)

For information on ordering AdBlue®/DEF (other markets), contact your local Volvo dealer.

**Actions in case of contact with AdBlue®/DEF:**

- In case of skin contact, rinse thoroughly with water. The fluid may cause irritation of the skin.
- In case of eye contact, rinse thoroughly for several minutes. If needed, contact a doctor for advice.
- In case of inhalation, breathe fresh air and contact a doctor if needed.
- If swallowed, drink water and contact a doctor.





358 Specifications  
Service capacities and change intervals

## Service capacities and change intervals

### Change capacities

Oils and other liquids	Change capacities
Engine oil, including filter	25 litres (6.6 US gal.)
Coolant	35 litres (9.2 US gal.)
Hydraulic tank	140 litres (37 US gal.)
Hydraulic system, total	290 litres (77 US gal.)
Swing gearbox	6.0 litres (1.6 US gal.)
Track gearbox (each)	5.8 litres (1.5 US gal.)
Fuel tank	320 litres (85 US gal.)
Swing ring gear	20 litres (5.3 US gal.) 18 kg (39.7 lb)
Oil bath pre-cleaner	3.0 litres (0.79 US gal.)
AdBlue®/DEF tank	27 litres (7.1 US gal.)



## Change intervals

### Filter changes

Filter	Hours
Engine oil filter	500
Fuel filter	500
Water separator filter element	500
Air cleaner, primary filter	After cleaning primary filter 5 times or every 2000 hours or maximum 1 year
Air cleaner, secondary filter	After changing primary filter 3 times or every 4000 hours or maximum 2 years
Air conditioner/heater main filter	2000
Air conditioner/heater main filter (HEPA filter, optional equipment)	500
Cab prefilter	2000
Cartridge of drain filter, hydraulic system	1000 (a)
Return oil filter, hydraulic system	2000 (a) *
Element of servo filter, hydraulic system	1000 (a)
Air ventilation filter, fuel tank	2000
Air breather filter, hydraulic tank	2000
Air filter of air compressor	2000
Return filter for hammer	250
Air breather filter, AdBlue®/DEF tank	6000
AdBlue®/DEF pump unit filter	6000

a) First change: 500 hours

\* When using the hydraulic hammer;

- Frequency of hammer use (50%): change the return oil filter every 1000 hours
- Frequency of hammer use (100%): change the return oil filter every 500 hours



**360**      Specifications  
**Service capacities and change intervals**

---

**Oil and liquid changes**

Oil/liquid	Hours
Engine oil	500 or maximum 1 year whichever comes first
Oil bath air cleaner oil	250 or when required
Coolant	6000 or maximum 4 years whichever comes first
Hydraulic oil (mineral oil)	2000 *
Hydraulic oil (bio oil and long life hydraulic oil)	5000
Swing drive unit oil	1000 (a)
Track drive unit oil	2000 (a)

a) First change: 500 hours

\* When using the hydraulic hammer;

- Frequency of hammer use (50%): change the hydraulic oil every 1000 hours
- Frequency of hammer use (100%): change the hydraulic oil every 600 hours



## Engine

### Engine, specifications

Designation	D6J
Number of cylinders	6
Cylinder bore	98 mm (3.86 in)
Stroke	126 mm (4.96 in)
Displacement	5.70 litres (348 in <sup>3</sup> )
Injection order	1-5-3-6-2-4
Power output at 30 r/s (1800 rpm)	129 kW (177 PS, 173 HP) SAE J1995 Gross
	128 kW (176 PS, 172 HP) ISO 9249 / SAE J1349 Net
Maximum torque	849 Nm (87 kgf m, 626 lbf ft) at 1350 rpm
Low idle	800 rpm
High idle	1900 rpm

### Carbon dioxide emissions

**NOTE!**

Only applicable to engine(s) quipped to meet the legal requirements for exhaust emissions according to EU Stage V.

The table below shows the value of the carbon dioxide (CO<sub>2</sub>) emission determined from EU-type approval testing of parent engine(s) in the warm part of the Non Road Transient Test Cycle (NRTC).

	Test cycle NRTC
Parent engine	With B7 fuel
D6J, CO <sub>2</sub> (g/kWh)	724.0



362 Specifications  
Electrical system

## Electrical system

System voltage	24 V
Starter	5.5 kW
Batteries	2 x 12 V
Alternator	28 V / 80 A
Horn sound level at 2 m	Min. 115 dB
Head light type	Halogen (70 W) LED (22 W)

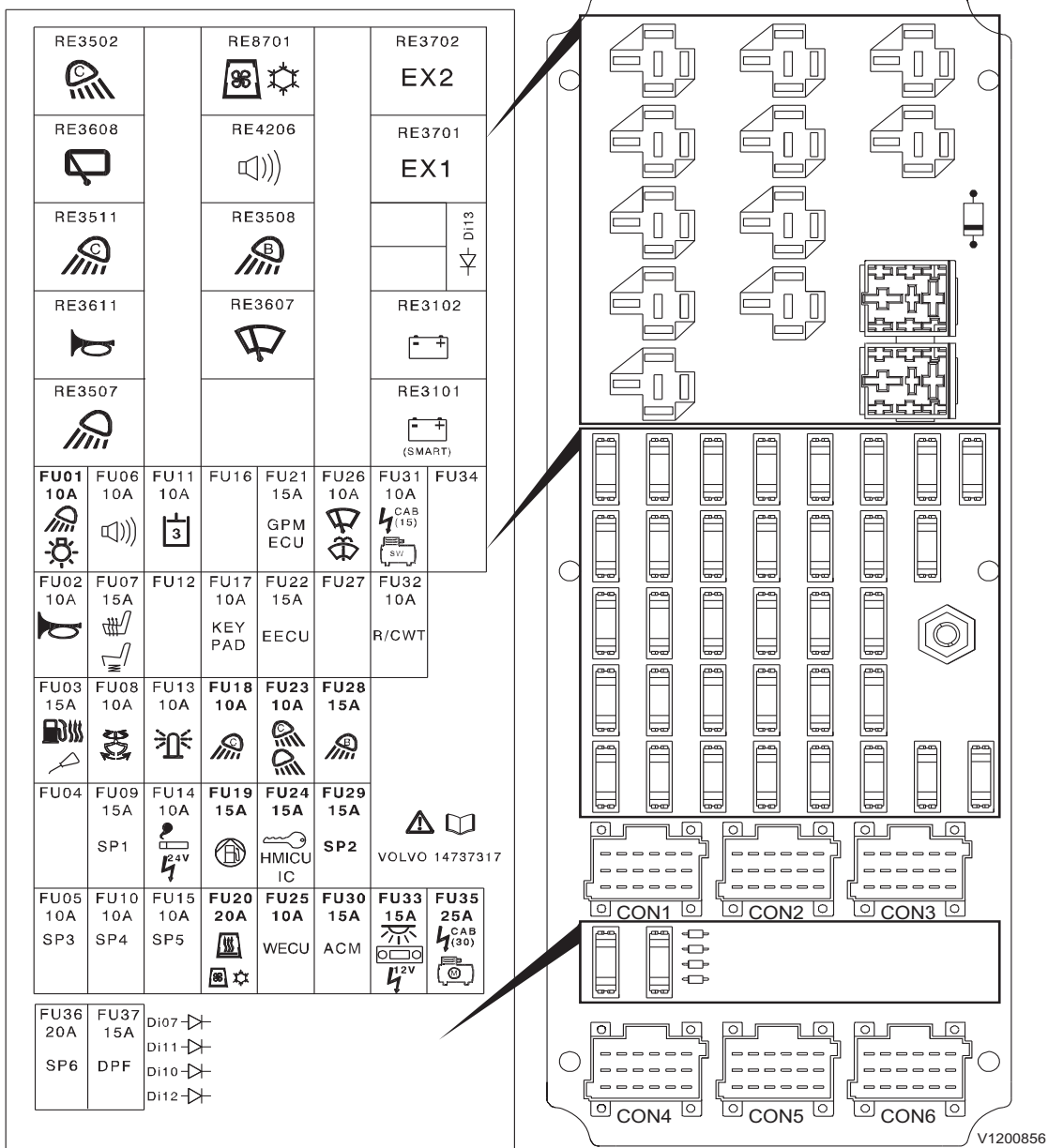



### Relays

No.	Capacity	Appliance / Circuit
RE3502	Relay	Work light (Counterweight)
RE3608	Relay	Lower wiper
RE3511	Relay	Work light (Cab)
RE3611	Relay	Horn
RE3507	Relay	Work light
RE8701	Relay	Air conditioner
RE4206	Relay	Travel alarm
RE3508	Relay	Work light (Boom)
RE3607	Relay	Upper wiper
RE3702	Relay	Spare relay
RE3701	Relay	Spare relay
RE3102	Relay	Main 2
RE3101	Relay	Main 1

### Fuses

No.	Capacity	Appliance / Circuit
FU01	10A	Work light (Boom, Deck)
FU02	10A	Horn
FU03	15A	Water separator heater, Auto lubrication
FU04	-	-
FU05	10A	Spare
FU06	10A	Travel alarm
FU07	15A	Seat heater, Air suspended seat heater
FU08	10A	Tiltrotator
FU09	15A	Spare
FU10	10A	Spare
FU11	10A	Hydraulic option 3
FU12	-	-
FU13	10A	Rotating warning beacon
FU14	10A	Cigarette lighter, Power socket (24V)
FU15	10A	Spare



**364**      Specifications  
**Electrical system**

No.	Capacity	Appliance / Circuit
FU16	-	-
FU17	10A	Keypad
FU18	10A	Work light (Cab)
FU19	15A	Fuel filler pump
FU20	20A	Auxiliary heater, Air conditioner
FU21	15A	GPMECU (General Purpose Machine Electronic Control Unit)
FU22	15A	EMS (Engine Management System)
FU23	10A	Work light (Counterweight)
FU24	15A	Ignition switch, HMICU (Human Machine Interface Control Unit), IC (Instrument Cluster)
FU25	10A	WECU (Telematics ECU)
FU26	10A	Wiper and washer
FU27	-	-
FU28	15A	Work light (Boom)
FU29	15A	Spare
FU30	15A	ACM (Aftertreatment Control Module)
FU31	10A	Power outlet
FU32	10A	Removable counterweight
FU33	15A	Interior light, Audio, Power outlet
FU34	-	-
FU35	25A	Air compressor
FU36	20A	Spare
FU37	15A	Diesel Particulate Filter



## Cab

### Operator seat

This machine is equipped with an operator seat, which meets the criteria of EN ISO 7096.

### Vibration and sound information

#### Hand-arm vibrations

Weighted root mean square (RMS) acceleration emission of the machine to which the arm is subjected for an 8 hours and at typical operating conditions of the machine equipped with mechanical suspension seat, is as follow. Measuring was carried out according to ISO 5349-1, ISO 5349-2 and ISO 8041 : 1990

- Excavating, mining (quarry), transfer movement and hydraulic breaker application is less than 2.5 m/s<sup>2</sup> A(8)

#### Whole-body vibrations

Weighted root mean square (RMS) acceleration emission of the machine to which the body is subjected for an 8 hours and at typical operating conditions of the machine equipped with mechanical suspension seat, is as follow. Measuring was carried out according to ISO 2631-1 : 1997 and ISO 8041 : 1990

- Excavating, mining (quarry) and hydraulic breaker application is less than 0.5 m/s<sup>2</sup> A(8)
- Transfer movement (traveling) is 0.5 ~ 0.9 m/s<sup>2</sup> A(8)

#### NOTE!

These whole body vibration values was determined at particular operating and terrain conditions and it is therefore not representative for the various conditions in accordance with the intended use of the machine. Consequently this whole body vibration emission value declared by the manufacturer in accordance with European Standard is not intended to determine the whole body vibration exposure to the operator using this machine.

To ensure that the whole-body vibration emission during machine use is kept to a minimum, see page 204.

#### Sound information

Sound pressure level (LpA) at operator position (Measurement according to ISO 6396)	Standard: 69 LpA dB(A) Tropical: 70 LpA dB(A)
Sound power level (LwA) around the machine (Measurement according to 2000/14/EC with applicable appendices and measuring method according to ISO 6395)	Standard: 102 LwA dB(A) Tropical: 103 LwA dB(A)





## Refrigerant

Type	Quantity	GWP <sup>(a)</sup>
R134a	0.8 kg (1.76 lb)	1144 kg CO <sub>2</sub> -eq

a) Global warming potential (GWP) is a measure of how much heat a gas traps in the atmosphere relative to that of carbon dioxide (CO<sub>2</sub>). GWP is calculated in terms of the 100-year warming potential of 1 kg of a greenhouse gas relative to 1 kg of CO<sub>2</sub>.



## Hydraulic system

Main pump	
Model	K3V112DT
Maximum flow rate	2 x 207 l/min (2 x 54.6 gpm)
Type	Variable displacement, axial piston pump

Servo pump	
Maximum flow	18 l/min (4.8 gpm)
Relief pressure	3.9 MPa (40 kgf cm <sup>2</sup> , 569 psi)

Main control valve	
Model	BK28
Main relief pressure (STD / Boost pressure)	34.3 / 36.3 MPa (350 / 370 kgf cm <sup>2</sup> , 4975 / 5265 psi)
Port relief pressure	Boom / Dipper arm / Bucket: 37.8 MPa (385 kgf cm <sup>2</sup> , 5483 psi)
2 stage port relief pressure (Standard)	Low / High: 20.6 / 37.8 MPa (210 / 385 kgf cm <sup>2</sup> , 2988 / 5483 psi)
Preset relief pressure (Option)	Low / High: 9.8 / 37.8 MPa (100 / 385 kgf cm <sup>2</sup> , 1421 / 5483 psi)

Control pedals		
Travel pedal	Model	PVD8P
	Stroke	5.5 mm (0.21 in)
	Operating force	10.6 Nm (1.08 kgf m) (7.84 lbf ft)
X1 pedal	Model	RCV8C
	Stroke	5.5 mm (0.21 in)
	Operating force	9.84 Nm (1.0 kgf m) (7.28 lbf ft)



**368 Specifications**  
**Hydraulic system**

<b>Control levers</b>		
One button type (Semi-long)	Model	PV48K
	Angle	Forward and backward: 19° Right and left: 25°
	Operating force	Forward and backward: 2.21 Nm (0.23 kgf m) (1.63 lbf ft) Right and left: 2.45 Nm (0.25 kgf m) (1.81 lbf ft)
Four buttons type Three buttons and proportional switch type	Model	PV48K
	Angle	Forward and backward: 19° Right and left: 19°
	Operating force	Forward and backward: 2.02 Nm (0.21 kgf m) (1.49 lbf ft) Right and left: 2.21 Nm (0.23 kgf m) (1.63 lbf ft)
<b>Track motor</b>		
Model	EM140V	
Type	Variable displacement axial piston motor with mechanical brake	
Relief valve setting pressure	34.3 MPa (350 kgf cm <sup>2</sup> ) (4975 psi)	
Brake type	Wet disc, spring applied, hydraulic released	
<b>Track gearbox</b>		
Type	2-stage planetary	
<b>Swing motor</b>		
Model	M5X130	
Type	Fixed displacement axial piston motor with mechanical brake	
Relief valve setting pressure	27.9 MPa (285 kgf cm <sup>2</sup> ) (4050 psi)	
<b>Swing gearbox</b>		
Type	2-stage planetary	

## Machine weights

### Disassembled parts, weight

#### Counterweight, weight

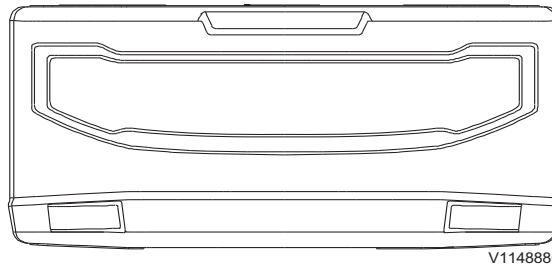

V1148886

Description	Unit	Counterweight	
		Weight	kg lb

#### Boom, weight

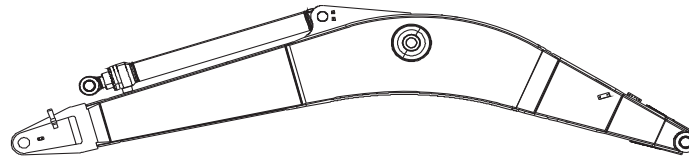

V1068040

Description	Unit	Boom			
		5.7 m (18' 8") GP	5.7 m (18' 8") HD	5.57 m (18' 3") VA	8.85 m (29' 0") LR
Weight	kg lb	2006 4420	2151 4740	2585 5700	2510 5530

\* Includes cylinder, piping and pin

GP: General Purpose  
 HD: Heavy Duty  
 VA: Variable Adjustable  
 LR: Long Reach

Specifications  
**370 Machine weights**

Dipper arm, weight

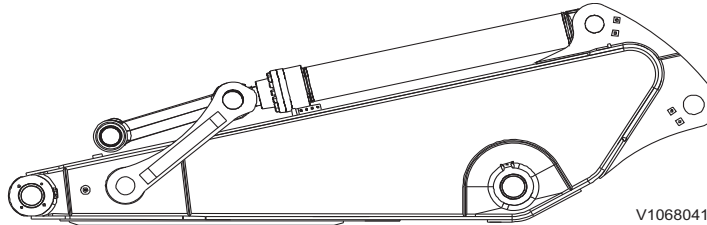

Description	Unit	Dipper arm					
		2.0 m (6' 7") ME	2.5 m (8' 2") HD	2.9 m (9' 6") GP	2.9 m (9' 6") HD	3.5 m (11' 6") GP	6.25 m (20' 6") LR
Weight	kg lb	1091 2410	1133 2500	1146 2530	1183 2610	1226 2700	1309 2890

\* Includes cylinder, linkage and pin

ME: Mass Excavation

GP: General Purpose

HD: Heavy Duty

LR: Long Reach



## Ground pressure

For Europe and Others

EC220E L

GP Boom (m/ft-in): 5.7 / 18' 8" ME Arm (m/ft-in): 2.0 / 6' 7" Bucket (l/kg/lb): 920 / 820 / 1810 Counterweight (kg/lb): 4200 / 9260				
Description	Shoe width (mm/in)	Operating weight (kg/lb)	Ground pressure (kPa/kgf cm <sup>2</sup> /psi)	Overall width (mm/ft-in)
Triple grouser	500 / 20	21429 / 47250	53.0 / 0.54 / 7.7	2890 / 9' 6"
	600 / 24	21687 / 47820	45.1 / 0.46 / 6.5	2990 / 9' 10"
	600 / 24 (HD)	21855 / 48190	45.1 / 0.46 / 6.5	2990 / 9' 10"
	700 / 28	22146 / 48830	39.2 / 0.4 / 5.7	3090 / 10' 2"
	800 / 32	22431 / 49460	35.3 / 0.36 / 5.1	3190 / 10' 6"
	900 / 35	22725 / 50110	31.4 / 0.32 / 4.6	3290 / 10' 10"
Single grouser	600 / 24	21895 / 48280	45.1 / 0.46 / 6.5	2990 / 9' 10"
Double grouser	700 / 28	22411 / 49420	40.2 / 0.41 / 5.8	3090 / 10' 2"

GP Boom (m/ft-in): 5.7 / 18' 8" HD Arm (m/ft-in): 2.5 / 8' 2" Bucket (l/kg/lb): 920 / 820 / 1810 Counterweight (kg/lb): 4200 / 9260				
Description	Shoe width (mm/in)	Operating weight (kg/lb)	Ground pressure (kPa/kgf cm <sup>2</sup> /psi)	Overall width (mm/ft-in)
Triple grouser	500 / 20	21438 / 47270	53.0 / 0.54 / 7.7	2890 / 9' 6"
	600 / 24	21696 / 47840	45.1 / 0.46 / 6.5	2990 / 9' 10"
	600 / 24 (HD)	21864 / 48210	45.1 / 0.46 / 6.5	2990 / 9' 10"
	700 / 28	22155 / 48850	39.2 / 0.4 / 5.7	3090 / 10' 2"
	800 / 32	22440 / 49480	35.3 / 0.36 / 5.1	3190 / 10' 6"
	900 / 35	22734 / 50130	31.4 / 0.32 / 4.6	3290 / 10' 10"
Single grouser	600 / 24	21904 / 48300	45.1 / 0.46 / 6.5	2990 / 9' 10"
Double grouser	700 / 28	22420 / 49440	40.2 / 0.41 / 5.8	3090 / 10' 2"

GP : General Purpose  
 ME : Mass Excavation  
 HD : Heavy Duty



**372**      Specifications  
**Ground pressure**

GP Boom (m/ft-in): 5.7 / 18' 8" GP Arm (m/ft-in): 2.9 / 9' 6" Bucket (l/kg/lb): 920 / 820 / 1810 Counterweight (kg/lb): 4200 / 9260				
Description	Shoe width (mm/in)	Operating weight (kg/lb)	Ground pressure (kPa/kgf cm <sup>2</sup> /psi)	Overall width (mm/ft-in)
Triple grouser	500 / 20	21442 / 47280	53.0 / 0.54 / 7.7	2890 / 9' 6"
	600 / 24	21700 / 47850	45.1 / 0.46 / 6.5	2990 / 9' 10"
	600 / 24 (HD)	21869 / 48220	45.1 / 0.46 / 6.5	2990 / 9' 10"
	700 / 28	22160 / 48860	39.2 / 0.4 / 5.7	3090 / 10' 2"
	800 / 32	22445 / 49490	35.3 / 0.36 / 5.1	3190 / 10' 6"
	900 / 35	22739 / 50140	31.4 / 0.32 / 4.6	3290 / 10' 10"
Single grouser	600 / 24	21909 / 48310	45.1 / 0.46 / 6.5	2990 / 9' 10"
Double grouser	700 / 28	22425 / 49450	40.2 / 0.41 / 5.8	3090 / 10' 2"

GP Boom (m/ft-in): 5.7 / 18' 8" HD Arm (m/ft-in): 2.9 / 9' 6" Bucket (l/kg/lb): 920 / 820 / 1810 Counterweight (kg/lb): 4200 / 9260				
Description	Shoe width (mm/in)	Operating weight (kg/lb)	Ground pressure (kPa/kgf cm <sup>2</sup> /psi)	Overall width (mm/ft-in)
Triple grouser	500 / 20	21494 / 47400	53.9 / 0.55 / 7.8	2890 / 9' 6"
	600 / 24	21753 / 47970	45.1 / 0.46 / 6.5	2990 / 9' 10"
	600 / 24 (HD)	21921 / 48340	45.1 / 0.46 / 6.5	2990 / 9' 10"
	700 / 28	22212 / 48980	39.2 / 0.4 / 5.7	3090 / 10' 2"
	800 / 32	22497 / 49610	35.3 / 0.36 / 5.1	3190 / 10' 6"
	900 / 35	22791 / 50250	31.4 / 0.32 / 4.6	3290 / 10' 10"
Single grouser	600 / 24	21961 / 48420	45.1 / 0.46 / 6.5	2990 / 9' 10"
Double grouser	700 / 28	22477 / 49560	40.2 / 0.41 / 5.8	3090 / 10' 2"

GP : General Purpose  
 HD : Heavy Duty



Specifications  
**Ground pressure**      **373**

GP Boom (m/ft-in): 5.7 / 18' 8"  
 GP Arm (m/ft-in): 3.5 / 11' 6"  
 Bucket (l/kg/lb): 920 / 820 / 1810  
 Counterweight (kg/lb): 4200 / 9260

Description	Shoe width (mm/in)	Operating weight (kg/lb)	Ground pressure (kPa/kgf cm <sup>2</sup> /psi)	Overall width (mm/ft-in)
Triple grouser	500 / 20	21558 / 47540	53.9 / 0.55 / 7.8	2890 / 9' 6"
	600 / 24	21816 / 48100	45.1 / 0.46 / 6.5	2990 / 9' 10"
	600 / 24 (HD)	21984 / 48470	45.1 / 0.46 / 6.5	2990 / 9' 10"
	700 / 28	22275 / 49120	39.2 / 0.4 / 5.7	3090 / 10' 2"
	800 / 32	22560 / 49740	35.3 / 0.36 / 5.1	3190 / 10' 6"
	900 / 35	22854 / 50390	31.4 / 0.32 / 4.6	3290 / 10' 10"
Single grouser	600 / 24	22024 / 48560	46.1 / 0.47 / 6.7	2990 / 9' 10"
Double grouser	700 / 28	22540 / 49700	40.2 / 0.41 / 5.8	3090 / 10' 2"

HD Boom (m/ft-in): 5.7 / 18' 8"  
 ME Arm (m/ft-in): 2.0 / 6' 7"  
 Bucket (l/kg/lb): 920 / 820 / 1810  
 Counterweight (kg/lb): 4200 / 9260

Description	Shoe width (mm/in)	Operating weight (kg/lb)	Ground pressure (kPa/kgf cm <sup>2</sup> /psi)	Overall width (mm/ft-in)
Triple grouser	500 / 20	21575 / 47570	53.9 / 0.55 / 7.8	2890 / 9' 6"
	600 / 24	21833 / 48140	45.1 / 0.46 / 6.5	2990 / 9' 10"
	600 / 24 (HD)	22001 / 48510	46.1 / 0.47 / 6.7	2990 / 9' 10"
	700 / 28	22292 / 49150	39.2 / 0.4 / 5.7	3090 / 10' 2"
	800 / 32	22577 / 49780	35.3 / 0.36 / 5.1	3190 / 10' 6"
	900 / 35	22871 / 50430	31.4 / 0.32 / 4.6	3290 / 10' 10"
Single grouser	600 / 24	22041 / 48600	46.1 / 0.47 / 6.7	2990 / 9' 10"
Double grouser	700 / 28	22557 / 49740	40.2 / 0.41 / 5.8	3090 / 10' 2"

GP : General Purpose  
 ME : Mass Excavation  
 HD : Heavy Duty





**374**      Specifications  
**Ground pressure**

HD Boom (m/ft-in): 5.7 / 18' 8" HD Arm (m/ft-in): 2.5 / 8' 2" Bucket (l/kg/lb): 920 / 820 / 1810 Counterweight (kg/lb): 4200 / 9260				
Description	Shoe width (mm/in)	Operating weight (kg/lb)	Ground pressure (kPa/kgf cm <sup>2</sup> /psi)	Overall width (mm/ft-in)
Triple grouser	500 / 20	21584 / 47590	53.9 / 0.55 / 7.8	2890 / 9' 6"
	600 / 24	21842 / 48160	45.1 / 0.46 / 6.5	2990 / 9' 10"
	600 / 24 (HD)	22010 / 48530	46.1 / 0.47 / 6.7	2990 / 9' 10"
	700 / 28	22301 / 49170	39.2 / 0.4 / 5.7	3090 / 10' 2"
	800 / 32	22586 / 49800	35.3 / 0.36 / 5.1	3190 / 10' 6"
	900 / 35	22880 / 50450	31.4 / 0.32 / 4.6	3290 / 10' 10"
Single grouser	600 / 24	22050 / 48620	46.1 / 0.47 / 6.7	2990 / 9' 10"
Double grouser	700 / 28	22567 / 49760	40.2 / 0.41 / 5.8	3090 / 10' 2"

HD Boom (m/ft-in): 5.7 / 18' 8" GP Arm (m/ft-in): 2.9 / 9' 6" Bucket (l/kg/lb): 920 / 820 / 1810 Counterweight (kg/lb): 4200 / 9260				
Description	Shoe width (mm/in)	Operating weight (kg/lb)	Ground pressure (kPa/kgf cm <sup>2</sup> /psi)	Overall width (mm/ft-in)
Triple grouser	500 / 20	21589 / 47600	53.9 / 0.55 / 7.8	2890 / 9' 6"
	600 / 24	21847 / 48170	45.1 / 0.46 / 6.5	2990 / 9' 10"
	600 / 24 (HD)	22015 / 48540	46.1 / 0.47 / 6.7	2990 / 9' 10"
	700 / 28	22306 / 49180	39.2 / 0.4 / 5.7	3090 / 10' 2"
	800 / 32	22591 / 49810	35.3 / 0.36 / 5.1	3190 / 10' 6"
	900 / 35	22885 / 50460	31.4 / 0.32 / 4.6	3290 / 10' 10"
Single grouser	600 / 24	22055 / 48630	46.1 / 0.47 / 6.7	2990 / 9' 10"
Double grouser	700 / 28	22571 / 49770	40.2 / 0.41 / 5.8	3090 / 10' 2"

GP : General Purpose  
 HD : Heavy Duty



Specifications  
**Ground pressure**      **375**

HD Boom (m/ft-in): 5.7 / 18' 8" HD Arm (m/ft-in): 2.9 / 9' 6" Bucket (l/kg/lb): 920 / 820 / 1810 Counterweight (kg/lb): 4200 / 9260				
Description	Shoe width (mm/in)	Operating weight (kg/lb)	Ground pressure (kPa/kgf cm <sup>2</sup> /psi)	Overall width (mm/ft-in)
Triple grouser	500 / 20	21641 / 47720	53.9 / 0.55 / 7.8	2890 / 9' 6"
	600 / 24	21899 / 48290	45.1 / 0.46 / 6.5	2990 / 9' 10"
	600 / 24 (HD)	22067 / 48660	46.1 / 0.47 / 6.7	2990 / 9' 10"
	700 / 28	22358 / 49300	40.2 / 0.41 / 5.8	3090 / 10' 2"
	800 / 32	22643 / 49930	35.3 / 0.36 / 5.1	3190 / 10' 6"
	900 / 35	22973 / 50580	31.4 / 0.32 / 4.6	3290 / 10' 10"
Single grouser	600 / 24	22107 / 48750	46.1 / 0.47 / 6.7	2990 / 9' 10"
Double grouser	700 / 28	22623 / 49880	40.2 / 0.41 / 5.8	3090 / 10' 2"

HD Boom (m/ft-in): 5.7 / 18' 8" GP Arm (m/ft-in): 3.5 / 11' 6" Bucket (l/kg/lb): 920 / 820 / 1810 Counterweight (kg/lb): 4200 / 9260				
Description	Shoe width (mm/in)	Operating weight (kg/lb)	Ground pressure (kPa/kgf cm <sup>2</sup> /psi)	Overall width (mm/ft-in)
Triple grouser	500 / 20	21704 / 47860	53.9 / 0.55 / 7.8	2890 / 9' 6"
	600 / 24	21962 / 48430	45.1 / 0.46 / 6.5	2990 / 9' 10"
	600 / 24 (HD)	22130 / 48800	46.1 / 0.47 / 6.7	2990 / 9' 10"
	700 / 28	22421 / 49440	40.2 / 0.41 / 5.8	3090 / 10' 2"
	800 / 32	22706 / 50070	35.3 / 0.36 / 5.1	3190 / 10' 6"
	900 / 35	23000 / 50720	31.4 / 0.32 / 4.6	3290 / 10' 10"
Single grouser	600 / 24	22170 / 48880	46.1 / 0.47 / 6.7	2990 / 9' 10"
Double grouser	700 / 28	22687 / 50020	40.2 / 0.41 / 5.8	3090 / 10' 2"

GP : General Purpose

HD : Heavy Duty



**376**      Specifications  
**Ground pressure**

VA Boom (m/ft-in): 5.57 / 18' 3" GP Arm (m/ft-in): 2.9 / 9' 6" Bucket (l/kg/lb): 920 / 820 / 1810 Counterweight (kg/lb): 4200 / 9260				
Description	Shoe width (mm/in)	Operating weight (kg/lb)	Ground pressure (kPa/kgf cm <sup>2</sup> /psi)	Overall width (mm/ft-in)
Triple grouser	500 / 20	22127 / 48790	54.9 / 0.56 / 8.0	2890 / 9' 6"
	600 / 24	22385 / 49360	46.1 / 0.47 / 6.7	2990 / 9' 10"
	600 / 24 (HD)	22553 / 49730	47.1 / 0.48 / 6.8	2990 / 9' 10"
	700 / 28	22844 / 50370	40.2 / 0.41 / 5.8	3090 / 10' 2"
	800 / 32	23129 / 51000	36.3 / 0.37 / 5.3	3190 / 10' 6"
	900 / 35	23423 / 51650	32.4 / 0.33 / 4.7	3290 / 10' 10"
Single grouser	600 / 24	22593 / 49820	47.1 / 0.48 / 6.8	2990 / 9' 10"
Double grouser	700 / 28	23110 / 50960	41.2 / 0.42 / 6.0	3090 / 10' 2"

VA Boom (m/ft-in): 5.57 / 18' 3" HD Arm (m/ft-in): 2.9 / 9' 6" Bucket (l/kg/lb): 920 / 820 / 1810 Counterweight (kg/lb): 4200 / 9260				
Description	Shoe width (mm/in)	Operating weight (kg/lb)	Ground pressure (kPa/kgf cm <sup>2</sup> /psi)	Overall width (mm/ft-in)
Triple grouser	500 / 20	22179 / 48900	54.9 / 0.56 / 8.0	2890 / 9' 6"
	600 / 24	22437 / 49470	46.1 / 0.47 / 6.7	2990 / 9' 10"
	600 / 24 (HD)	22605 / 49840	47.1 / 0.48 / 6.8	2990 / 9' 10"
	700 / 28	22896 / 50490	41.2 / 0.42 / 6.0	3090 / 10' 2"
	800 / 32	23181 / 51110	36.3 / 0.37 / 5.3	3190 / 10' 6"
	900 / 35	23478 / 51770	32.4 / 0.33 / 4.7	3290 / 10' 10"
Single grouser	600 / 24	22645 / 49930	47.1 / 0.48 / 6.8	2990 / 9' 10"
Double grouser	700 / 28	23162 / 51070	41.2 / 0.42 / 6.0	3090 / 10' 2"

GP : General Purpose  
 VA : Variable Adjustable  
 HD : Heavy Duty



Specifications  
Ground pressure **377**

VA Boom (m/ft-in): 5.57 / 18' 3" GP Arm (m/ft-in): 3.5 / 11' 6" Bucket (l/kg/lb): 920 / 820 / 1810 Counterweight (kg/lb): 4200 / 9260				
Description	Shoe width (mm/in)	Operating weight (kg/lb)	Ground pressure (kPa/kgf cm <sup>2</sup> /psi)	Overall width (mm/ft-in)
Triple grouser	500 / 20	22242 / 49040	54.9 / 0.56 / 8.0	2890 / 9' 6"
	600 / 24	22500 / 49610	47.1 / 0.48 / 6.8	2990 / 9' 10"
	600 / 24 (HD)	22668 / 49980	47.1 / 0.48 / 6.8	2990 / 9' 10"
	700 / 28	22959 / 50630	41.2 / 0.42 / 6.0	3090 / 10' 2"
	800 / 32	23244 / 51250	36.3 / 0.37 / 5.3	3190 / 10' 6"
	900 / 35	23538 / 51900	32.4 / 0.33 / 4.7	3290 / 10' 10"
Single grouser	600 / 24	22708 / 50070	47.1 / 0.48 / 6.8	2990 / 9' 10"
Double grouser	700 / 28	23225 / 51210	41.2 / 0.42 / 6.0	3090 / 10' 2"

GP : General Purpose  
 VA : Variable Adjustable  
 HD : Heavy Duty



378 Specifications  
Ground pressure

EC220E NL

GP Boom (m/ft-in): 5.7 / 18' 8" ME Arm (m/ft-in): 2.0 / 6' 7" Bucket (l/kg/lb): 920 / 820 / 1810 Counterweight (kg/lb): 5000 / 11030				
Description	Shoe width (mm/in)	Operating weight (kg/lb)	Ground pressure (kPa/kgf cm <sup>2</sup> /psi)	Overall width (mm/ft-in)
Triple grouser	500 / 20	22141 / 48820	54.9 / 0.56 / 8.0	2540 / 8' 4"
	600 / 24	22399 / 49390	46.1 / 0.47 / 6.7	2640 / 8' 8"
	600 / 24 (HD)	22567 / 49760	47.1 / 0.48 / 6.8	2640 / 8' 8"
	700 / 28	22858 / 50400	40.2 / 0.41 / 5.8	2740 / 8' 12"
Double grouser	700 / 28	23123 / 50990	41.2 / 0.42 / 6.0	2740 / 8' 12"

GP Boom (m/ft-in): 5.7 / 18' 8" HD Arm (m/ft-in): 2.5 / 8' 2" Bucket (l/kg/lb): 920 / 820 / 1810 Counterweight (kg/lb): 5000 / 11030				
Description	Shoe width (mm/in)	Operating weight (kg/lb)	Ground pressure (kPa/kgf cm <sup>2</sup> /psi)	Overall width (mm/ft-in)
Triple grouser	500 / 20	22150 / 48840	54.9 / 0.56 / 8.0	2540 / 8' 4"
	600 / 24	22408 / 49410	46.1 / 0.47 / 6.7	2640 / 8' 8"
	600 / 24 (HD)	22576 / 49780	47.1 / 0.48 / 6.8	2640 / 8' 8"
	700 / 28	22867 / 50420	40.2 / 0.41 / 5.8	2740 / 8' 12"
Double grouser	700 / 28	23132 / 51010	41.2 / 0.42 / 6.0	2740 / 8' 12"

GP : General Purpose  
 ME : Mass Excavation  
 HD : Heavy Duty



Specifications  
**Ground pressure**      **379**

GP Boom (m/ft-in): 5.7 / 18' 8"  
 GP Arm (m/ft-in): 2.9 / 9' 6"  
 Bucket (l/kg/lb): 920 / 820 / 1810  
 Counterweight (kg/lb): 5000 / 11030

Description	Shoe width (mm/in)	Operating weight (kg/lb)	Ground pressure (kPa/kgf cm <sup>2</sup> /psi)	Overall width (mm/ft-in)
Triple grouser	500 / 20	22154 / 48850	54.9 / 0.56 / 8.0	2540 / 8' 4"
	600 / 24	22413 / 49420	46.1 / 0.47 / 6.7	2640 / 8' 8"
	600 / 24 (HD)	22581 / 49790	47.1 / 0.48 / 6.8	2640 / 8' 8"
	700 / 28	22872 / 50430	40.2 / 0.41 / 5.8	2740 / 8' 12"
Double grouser	700 / 28	23137 / 51020	41.2 / 0.42 / 6.0	2740 / 8' 12"

GP Boom (m/ft-in): 5.7 / 18' 8"  
 HD Arm (m/ft-in): 2.9 / 9' 6"  
 Bucket (l/kg/lb): 920 / 820 / 1810  
 Counterweight (kg/lb): 5000 / 11030

Description	Shoe width (mm/in)	Operating weight (kg/lb)	Ground pressure (kPa/kgf cm <sup>2</sup> /psi)	Overall width (mm/ft-in)
Triple grouser	500 / 20	22207 / 48970	54.9 / 0.56 / 8.0	2540 / 8' 4"
	600 / 24	22465 / 49540	47.1 / 0.48 / 6.8	2640 / 8' 8"
	600 / 24 (HD)	22633 / 49910	47.1 / 0.48 / 6.8	2640 / 8' 8"
	700 / 28	22924 / 50550	41.2 / 0.42 / 6.0	2740 / 8' 12"
Double grouser	700 / 28	23189 / 51130	41.2 / 0.42 / 6.0	2740 / 8' 12"

GP : General Purpose  
 HD : Heavy Duty



**380** Specifications  
**Ground pressure**

GP Boom (m/ft-in): 5.7 / 18' 8"  
 GP Arm (m/ft-in): 3.5 / 11' 6"  
 Bucket (l/kg/lb): 920 / 820 / 1810  
 Counterweight (kg/lb): 5000 / 11030

Description	Shoe width (mm/in)	Operating weight (kg/lb)	Ground pressure (kPa/kgf cm <sup>2</sup> /psi)	Overall width (mm/ft-in)
Triple grouser	500 / 20	22270 / 49110	55.9 / 0.57 / 8.1	2540 / 8' 4"
	600 / 24	22528 / 49670	47.1 / 0.48 / 6.8	2640 / 8' 8"
	600 / 24 (HD)	22696 / 50040	47.1 / 0.48 / 6.8	2640 / 8' 8"
	700 / 28	22987 / 50690	41.2 / 0.42 / 6.0	2740 / 8' 12"
Double grouser	700 / 28	23252 / 51270	41.2 / 0.42 / 6.0	2740 / 8' 12"

HD Boom (m/ft-in): 5.7 / 18' 8"  
 ME Arm (m/ft-in): 2.0 / 6' 7"  
 Bucket (l/kg/lb): 920 / 820 / 1810  
 Counterweight (kg/lb): 5000 / 11030

Description	Shoe width (mm/in)	Operating weight (kg/lb)	Ground pressure (kPa/kgf cm <sup>2</sup> /psi)	Overall width (mm/ft-in)
Triple grouser	500 / 20	22287 / 49140	55.9 / 0.57 / 8.1	2540 / 8' 4"
	600 / 24	22545 / 49710	47.1 / 0.48 / 6.8	2640 / 8' 8"
	600 / 24 (HD)	22713 / 50080	47.1 / 0.48 / 6.8	2640 / 8' 8"
	700 / 28	23004 / 50720	41.2 / 0.42 / 6.0	2740 / 8' 12"
Double grouser	700 / 28	23270 / 51310	41.2 / 0.42 / 6.0	2740 / 8' 12"

GP : General Purpose  
 ME : Mass Excavation  
 HD : Heavy Duty





Specifications  
**Ground pressure**      **381**

HD Boom (m/ft-in): 5.7 / 18' 8"  
 HD Arm (m/ft-in): 2.5 / 8' 2"  
 Bucket (l/kg/lb): 920 / 820 / 1810  
 Counterweight (kg/lb): 5000 / 11030

Description	Shoe width (mm/in)	Operating weight (kg/lb)	Ground pressure (kPa/kgf cm <sup>2</sup> /psi)	Overall width (mm/ft-in)
Triple grouser	500 / 20	22296 / 49160	55.9 / 0.57 / 8.1	2540 / 8' 4"
	600 / 24	22554 / 49730	47.1 / 0.48 / 6.8	2640 / 8' 8"
	600 / 24 (HD)	22722 / 50100	47.1 / 0.48 / 6.8	2640 / 8' 8"
	700 / 28	23013 / 50740	41.2 / 0.42 / 6.0	2740 / 8' 12"
Double grouser	700 / 28	23279 / 51330	41.2 / 0.42 / 6.0	2740 / 8' 12"

HD Boom (m/ft-in): 5.7 / 18' 8"  
 GP Arm (m/ft-in): 2.9 / 9' 6"  
 Bucket (l/kg/lb): 920 / 820 / 1810  
 Counterweight (kg/lb): 5000 / 11030

Description	Shoe width (mm/in)	Operating weight (kg/lb)	Ground pressure (kPa/kgf cm <sup>2</sup> /psi)	Overall width (mm/ft-in)
Triple grouser	500 / 20	22301 / 49170	55.9 / 0.57 / 8.1	2540 / 8' 4"
	600 / 24	22559 / 49740	47.1 / 0.48 / 6.8	2640 / 8' 8"
	600 / 24 (HD)	22727 / 50110	47.1 / 0.48 / 6.8	2640 / 8' 8"
	700 / 28	23018 / 50750	41.2 / 0.42 / 6.0	2740 / 8' 12"
Double grouser	700 / 28	23283 / 51340	41.2 / 0.42 / 6.0	2740 / 8' 12"

GP : General Purpose  
 HD : Heavy Duty





**382**      Specifications  
**Ground pressure**

HD Boom (m/ft-in): 5.7 / 18' 8" HD Arm (m/ft-in): 2.9 / 9' 6" Bucket (l/kg/lb): 920 / 820 / 1810 Counterweight (kg/lb): 5000 / 11030				
Description	Shoe width (mm/in)	Operating weight (kg/lb)	Ground pressure (kPa/kgf cm <sup>2</sup> /psi)	Overall width (mm/ft-in)
Triple grouser	500 / 20	22353 / 49290	55.9 / 0.57 / 8.1	2540 / 8' 4"
	600 / 24	22611 / 49860	47.1 / 0.48 / 6.8	2640 / 8' 8"
	600 / 24 (HD)	22779 / 50230	47.1 / 0.48 / 6.8	2640 / 8' 8"
	700 / 28	23070 / 50870	41.2 / 0.42 / 6.0	2740 / 8' 12"
Double grouser	700 / 28	23336 / 51460	41.2 / 0.42 / 6.0	2740 / 8' 12"

GP Boom (m/ft-in): 5.7 / 18' 8" GP Arm (m/ft-in): 3.5 / 11' 6" Bucket (l/kg/lb): 920 / 820 / 1810 Counterweight (kg/lb): 5000 / 11030				
Description	Shoe width (mm/in)	Operating weight (kg/lb)	Ground pressure (kPa/kgf cm <sup>2</sup> /psi)	Overall width (mm/ft-in)
Triple grouser	500 / 20	22416 / 49430	55.9 / 0.57 / 8.1	2540 / 8' 4"
	600 / 24	22674 / 50000	47.1 / 0.48 / 6.8	2640 / 8' 8"
	600 / 24 (HD)	22842 / 50370	47.1 / 0.48 / 6.8	2640 / 8' 8"
	700 / 28	23133 / 51010	41.2 / 0.42 / 6.0	2740 / 8' 12"
Double grouser	700 / 28	23399 / 51590	41.2 / 0.42 / 6.0	2740 / 8' 12"

GP : General Purpose  
 HD : Heavy Duty



Specifications  
**Ground pressure**      **383**

VA Boom (m/ft-in): 5.57 / 18' 3"  
 GP Arm (m/ft-in): 2.9 / 9' 6"  
 Bucket (l/kg/lb): 920 / 820 / 1810  
 Counterweight (kg/lb): 5000 / 11030

Description	Shoe width (mm/in)	Operating weight (kg/lb)	Ground pressure (kPa/kgf cm <sup>2</sup> /psi)	Overall width (mm/ft-in)
Triple grouser	500 / 20	22839 / 50360	56.9 / 0.58 / 8.2	2540 / 8' 4"
	600 / 24	23097 / 50930	48.0 / 0.49 / 7.0	2640 / 8' 8"
	600 / 24 (HD)	23265 / 51300	48.0 / 0.49 / 7.0	2640 / 8' 8"
	700 / 28	23556 / 51940	42.2 / 0.43 / 6.1	2740 / 8' 12"
Double grouser	700 / 28	23822 / 52530	42.2 / 0.43 / 6.1	2740 / 8' 12"

VA Boom (m/ft-in): 5.57 / 18' 3"  
 HD Arm (m/ft-in): 2.9 / 9' 6"  
 Bucket (l/kg/lb): 920 / 820 / 1810  
 Counterweight (kg/lb): 5000 / 11030

Description	Shoe width (mm/in)	Operating weight (kg/lb)	Ground pressure (kPa/kgf cm <sup>2</sup> /psi)	Overall width (mm/ft-in)
Triple grouser	500 / 20	22891 / 50470	56.9 / 0.58 / 8.2	2540 / 8' 4"
	600 / 24	23149 / 51040	48.0 / 0.49 / 7.0	2640 / 8' 8"
	600 / 24 (HD)	23317 / 51410	48.0 / 0.49 / 7.0	2640 / 8' 8"
	700 / 28	23608 / 52060	42.2 / 0.43 / 6.1	2740 / 8' 12"
Double grouser	700 / 28	23874 / 52640	42.2 / 0.43 / 6.1	2740 / 8' 12"

GP : General Purpose  
 VA : Variable Adjustable  
 HD : Heavy Duty



**384**      Specifications  
Ground pressure

VA Boom (m/ft-in): 5.57 / 18' 3" GP Arm (m/ft-in): 3.5 / 11' 6" Bucket (l/kg/lb): 920 / 820 / 1810 Counterweight (kg/lb): 5000 / 11030				
Description	Shoe width (mm/in)	Operating weight (kg/lb)	Ground pressure (kPa/kgf cm <sup>2</sup> /psi)	Overall width (mm/ft-in)
Triple grouser	500 / 20	22954 / 50610	56.9 / 0.58 / 8.2	2540 / 8' 4"
	600 / 24	23212 / 51180	48.0 / 0.49 / 7.0	2640 / 8' 8"
	600 / 24 (HD)	23380 / 51550	48.0 / 0.49 / 7.0	2640 / 8' 8"
	700 / 28	23671 / 52190	42.2 / 0.43 / 6.1	2740 / 8' 12"
Double grouser	700 / 28	23937 / 52780	42.2 / 0.43 / 6.1	2740 / 8' 12"

GP : General Purpose  
 VA : Variable Adjustable  
 HD : Heavy Duty



Specifications  
**Ground pressure**      **385**

**EC220E N**

GP Boom (m/ft-in): 5.7 / 18' 8"  
 ME Arm (m/ft-in): 2.0 / 6' 7"  
 Bucket (l/kg/lb): 920 / 820 / 1810  
 Counterweight (kg/lb): 4200 / 9260

Description	Shoe width (mm/in)	Operating weight (kg/lb)	Ground pressure (kPa/kgf cm <sup>2</sup> /psi)	Overall width (mm/ft-in)
Triple grouser	600 / 24	21265 / 46890	48.0 / 0.49 / 7.0	2800 / 9' 2"
	600 / 24 (HD)	21423 / 47240	48.0 / 0.49 / 7.0	2800 / 9' 2"
	700 / 28	21697 / 47840	41.2 / 0.42 / 6.0	2900 / 9' 6"
	800 / 32	21965 / 48430	37.3 / 0.38 / 5.4	3000 / 9' 10"
	900 / 35	22241 / 49040	33.3 / 0.34 / 4.8	3100 / 10' 2"

GP Boom (m/ft-in): 5.7 / 18' 8"  
 HD Arm (m/ft-in): 2.5 / 8' 2"  
 Bucket (l/kg/lb): 920 / 820 / 1810  
 Counterweight (kg/lb): 4200 / 9260

Description	Shoe width (mm/in)	Operating weight (kg/lb)	Ground pressure (kPa/kgf cm <sup>2</sup> /psi)	Overall width (mm/ft-in)
Triple grouser	600 / 24	21275 / 46910	48.0 / 0.49 / 7.0	2800 / 9' 2"
	600 / 24 (HD)	21433 / 47260	48.0 / 0.49 / 7.0	2800 / 9' 2"
	700 / 28	21706 / 47860	41.2 / 0.42 / 6.0	2900 / 9' 6"
	800 / 32	21974 / 48450	37.3 / 0.38 / 5.4	3000 / 9' 10"
	900 / 35	22212 / 48980	33.3 / 0.34 / 4.8	3100 / 10' 2"

GP : General Purpose  
 ME : Mass Excavation  
 HD : Heavy Duty



**386** Specifications  
**Ground pressure**

GP Boom (m/ft-in): 5.7 / 18' 8"  
 GP Arm (m/ft-in): 2.9 / 9' 6"  
 Bucket (l/kg/lb): 920 / 820 / 1810  
 Counterweight (kg/lb): 4200 / 9260

Description	Shoe width (mm/in)	Operating weight (kg/lb)	Ground pressure (kPa/kgf cm <sup>2</sup> /psi)	Overall width (mm/ft-in)
Triple grouser	600 / 24	21279 / 46920	48.0 / 0.49 / 7.0	2800 / 9' 2"
	600 / 24 (HD)	21437 / 47270	48.0 / 0.49 / 7.0	2800 / 9' 2"
	700 / 28	21711 / 47870	41.2 / 0.42 / 6.0	2900 / 9' 6"
	800 / 32	21979 / 48460	37.3 / 0.38 / 5.4	3000 / 9' 10"
	900 / 35	22216 / 48990	33.3 / 0.34 / 4.8	3100 / 10' 2"

GP Boom (m/ft-in): 5.7 / 18' 8"  
 HD Arm (m/ft-in): 2.9 / 9' 6"  
 Bucket (l/kg/lb): 920 / 820 / 1810  
 Counterweight (kg/lb): 4200 / 9260

Description	Shoe width (mm/in)	Operating weight (kg/lb)	Ground pressure (kPa/kgf cm <sup>2</sup> /psi)	Overall width (mm/ft-in)
Triple grouser	600 / 24	21331 / 47030	48.0 / 0.49 / 7.0	2800 / 9' 2"
	600 / 24 (HD)	21489 / 47380	48.0 / 0.49 / 7.0	2800 / 9' 2"
	700 / 28	21763 / 47990	42.2 / 0.43 / 6.1	2900 / 9' 6"
	800 / 32	20231 / 48580	37.3 / 0.38 / 5.4	3000 / 9' 10"
	900 / 35	22268 / 49100	33.3 / 0.34 / 4.8	3100 / 10' 2"

GP : General Purpose  
 HD : Heavy Duty



Specifications  
**Ground pressure**      **387**

GP Boom (m/ft-in): 5.7 / 18' 8"  
 GP Arm (m/ft-in): 3.5 / 11' 6"  
 Bucket (l/kg/lb): 920 / 820 / 1810  
 Counterweight (kg/lb): 4200 / 9260

Description	Shoe width (mm/in)	Operating weight (kg/lb)	Ground pressure (kPa/kgf cm <sup>2</sup> /psi)	Overall width (mm/ft-in)
Triple grouser	600 / 24	21394 / 47170	48.0 / 0.49 / 7.0	2800 / 9' 2"
	600 / 24 (HD)	21552 / 47520	48.0 / 0.49 / 7.0	2800 / 9' 2"
	700 / 28	21826 / 48130	42.2 / 0.43 / 6.1	2900 / 9' 6"
	800 / 32	22094 / 48720	37.3 / 0.38 / 5.4	3000 / 9' 10"
	900 / 35	22332 / 49240	33.3 / 0.34 / 4.8	3100 / 10' 2"

HD Boom (m/ft-in): 5.7 / 18' 8"  
 ME Arm (m/ft-in): 2.0 / 6' 7"  
 Bucket (l/kg/lb): 920 / 820 / 1810  
 Counterweight (kg/lb): 4200 / 9260

Description	Shoe width (mm/in)	Operating weight (kg/lb)	Ground pressure (kPa/kgf cm <sup>2</sup> /psi)	Overall width (mm/ft-in)
Triple grouser	600 / 24	21412 / 47210	48.0 / 0.49 / 7.0	2800 / 9' 2"
	600 / 24 (HD)	21570 / 47560	48.0 / 0.49 / 7.0	2800 / 9' 2"
	700 / 28	21843 / 48160	42.2 / 0.43 / 6.1	2900 / 9' 6"
	800 / 32	22111 / 48750	37.3 / 0.38 / 5.4	3000 / 9' 10"
	900 / 35	22349 / 49280	33.3 / 0.34 / 4.8	3100 / 10' 2"

GP : General Purpose  
 ME : Mass Excavation  
 HD : Heavy Duty



**388 Specifications**  
**Ground pressure**

HD Boom (m/ft-in): 5.7 / 18' 8" HD Arm (m/ft-in): 2.5 / 8' 2" Bucket (l/kg/lb): 920 / 820 / 1810 Counterweight (kg/lb): 4200 / 9260				
Description	Shoe width (mm/in)	Operating weight (kg/lb)	Ground pressure (kPa/kgf cm <sup>2</sup> /psi)	Overall width (mm/ft-in)
Triple grouser	600 / 24	21421 / 47230	48.0 / 0.49 / 7.0	2800 / 9' 2"
	600 / 24 (HD)	21579 / 47580	48.0 / 0.49 / 7.0	2800 / 9' 2"
	700 / 28	21852 / 48180	42.2 / 0.43 / 6.1	2900 / 9' 6"
	800 / 32	22120 / 48770	37.3 / 0.38 / 5.4	3000 / 9' 10"
	900 / 35	22349 / 49280	33.3 / 0.34 / 4.8	3100 / 10' 2"

HD Boom (m/ft-in): 5.7 / 18' 8" GP Arm (m/ft-in): 2.9 / 9' 6" Bucket (l/kg/lb): 920 / 820 / 1810 Counterweight (kg/lb): 4200 / 9260				
Description	Shoe width (mm/in)	Operating weight (kg/lb)	Ground pressure (kPa/kgf cm <sup>2</sup> /psi)	Overall width (mm/ft-in)
Triple grouser	600 / 24	21425 / 47240	48.0 / 0.49 / 7.0	2800 / 9' 2"
	600 / 24 (HD)	21584 / 47590	48.0 / 0.49 / 7.0	2800 / 9' 2"
	700 / 28	21852 / 48180	42.2 / 0.43 / 6.1	2900 / 9' 6"
	800 / 32	22120 / 48770	37.3 / 0.38 / 5.4	3000 / 9' 10"
	900 / 35	22358 / 49300	33.3 / 0.34 / 4.8	3100 / 10' 2"

GP : General Purpose  
 HD : Heavy Duty



Specifications  
**Ground pressure**      **389**

HD Boom (m/ft-in): 5.7 / 18' 8"  
 HD Arm (m/ft-in): 2.9 / 9' 6"  
 Bucket (l/kg/lb): 920 / 820 / 1810  
 Counterweight (kg/lb): 4200 / 9260

Description	Shoe width (mm/in)	Operating weight (kg/lb)	Ground pressure (kPa/kgf cm <sup>2</sup> /psi)	Overall width (mm/ft-in)
Triple grouser	600 / 24	21478 / 47360	48.0 / 0.49 / 7.0	2800 / 9' 2"
	600 / 24 (HD)	21636 / 47710	48.0 / 0.49 / 7.0	2800 / 9' 2"
	700 / 28	21909 / 48310	42.2 / 0.43 / 6.1	2900 / 9' 6"
	800 / 32	22177 / 48900	37.3 / 0.38 / 5.4	3000 / 9' 10"
	900 / 35	22415 / 49430	33.3 / 0.34 / 4.8	3100 / 10' 2"

GP Boom (m/ft-in): 5.7 / 18' 8"  
 GP Arm (m/ft-in): 3.5 / 11' 6"  
 Bucket (l/kg/lb): 920 / 820 / 1810  
 Counterweight (kg/lb): 4200 / 9260

Description	Shoe width (mm/in)	Operating weight (kg/lb)	Ground pressure (kPa/kgf cm <sup>2</sup> /psi)	Overall width (mm/ft-in)
Triple grouser	600 / 24	21541 / 47500	48.0 / 0.49 / 7.0	2800 / 9' 2"
	600 / 24 (HD)	21699 / 47850	49.0 / 0.5 / 7.1	2800 / 9' 2"
	700 / 28	21909 / 48310	42.2 / 0.43 / 6.1	2900 / 9' 6"
	800 / 32	22177 / 48900	37.3 / 0.38 / 5.4	3000 / 9' 10"
	900 / 35	22415 / 49430	33.3 / 0.34 / 4.8	3100 / 10' 2"

GP : General Purpose  
 HD : Heavy Duty





**390** Specifications  
**Ground pressure**

VA Boom (m/ft-in): 5.57 / 18' 3" GP Arm (m/ft-in): 2.9 / 9' 6" Bucket (l/kg/lb): 920 / 820 / 1810 Counterweight (kg/lb): 4200 / 9260				
Description	Shoe width (mm/in)	Operating weight (kg/lb)	Ground pressure (kPa/kgf cm <sup>2</sup> /psi)	Overall width (mm/ft-in)
Triple grouser	600 / 24	21964 / 48430	49.0 / 0.5 / 7.1	2800 / 9' 2"
	600 / 24 (HD)	22122 / 48780	50.0 / 0.51 / 7.3	2800 / 9' 2"
	700 / 28	22395 / 49380	43.1 / 0.44 / 6.3	2900 / 9' 6"
	800 / 32	22663 / 49970	38.2 / 0.39 / 5.5	3000 / 9' 10"
	900 / 35	22901 / 50500	34.3 / 0.35 / 5.0	3100 / 10' 2"

VA Boom (m/ft-in): 5.57 / 18' 3" HD Arm (m/ft-in): 2.9 / 9' 6" Bucket (l/kg/lb): 920 / 820 / 1810 Counterweight (kg/lb): 4200 / 9260				
Description	Shoe width (mm/in)	Operating weight (kg/lb)	Ground pressure (kPa/kgf cm <sup>2</sup> /psi)	Overall width (mm/ft-in)
Triple grouser	600 / 24	22016 / 48550	49.0 / 0.5 / 7.1	2800 / 9' 2"
	600 / 24 (HD)	22174 / 48890	50.0 / 0.51 / 7.3	2800 / 9' 2"
	700 / 28	22447 / 49500	43.1 / 0.44 / 6.3	2900 / 9' 6"
	800 / 32	22715 / 50090	38.2 / 0.39 / 5.5	3000 / 9' 10"
	900 / 35	22953 / 50610	34.3 / 0.35 / 5.0	3100 / 10' 2"

GP : General Purpose  
 VA : Variable Adjustable  
 HD : Heavy Duty



Specifications  
**Ground pressure**      **391**

VA Boom (m/ft-in): 5.57 / 18' 3" GP Arm (m/ft-in): 3.5 / 11' 6" Bucket (l/kg/lb): 920 / 820 / 1810 Counterweight (kg/lb): 4200 / 9260				
Description	Shoe width (mm/in)	Operating weight (kg/lb)	Ground pressure (kPa/kgf cm <sup>2</sup> /psi)	Overall width (mm/ft-in)
Triple grouser	500 / 20	22079 / 48680	54.9 / 0.56 / 8.0	2540 / 8' 4"
	600 / 24	22237 / 49030	46.1 / 0.47 / 6.7	2640 / 8' 8"
	600 / 24 (HD)	22510 / 49630	47.1 / 0.48 / 6.8	2640 / 8' 8"
	700 / 28	22778 / 50230	40.2 / 0.41 / 5.8	2740 / 8' 12"
Double grouser	700 / 28	23016 / 50750	41.2 / 0.42 / 6.0	2740 / 8' 12"

VA : Variable Adjustable  
 HD : Heavy Duty



392 Specifications  
Ground pressure

EC220E NH

GP Boom (m/ft-in): 5.7 / 18' 8" ME Arm (m/ft-in): 2.0 / 6' 7" Bucket (l/kg/lb): 920 / 820 / 1810 Counterweight (kg/lb): 5000 / 11030				
Description	Shoe width (mm/in)	Operating weight (kg/lb)	Ground pressure (kPa/kgf cm <sup>2</sup> /psi)	Overall width (mm/ft-in)
Triple grouser	500 / 20	23257 / 51280	62.8 / 0.64 / 9.1	2700 / 8' 10"
	600 / 24	23573 / 51980	53.0 / 0.54 / 7.7	2800 / 9' 2"
	700 / 28	24094 / 53130	46.1 / 0.47 / 6.7	2900 / 9' 6"
GP Boom (m/ft-in): 5.7 / 18' 8" HD Arm (m/ft-in): 2.5 / 8' 2" Bucket (l/kg/lb): 920 / 820 / 1810 Counterweight (kg/lb): 5000 / 11030				
Description	Shoe width (mm/in)	Operating weight (kg/lb)	Ground pressure (kPa/kgf cm <sup>2</sup> /psi)	Overall width (mm/ft-in)
Triple grouser	500 / 20	23267 / 51300	62.8 / 0.64 / 9.1	2700 / 8' 10"
	600 / 24	23582 / 52000	53.0 / 0.54 / 7.7	2800 / 9' 2"
	700 / 28	24104 / 53150	46.1 / 0.47 / 6.7	2900 / 9' 6"
GP Boom (m/ft-in): 5.7 / 18' 8" GP Arm (m/ft-in): 2.9 / 9' 6" Bucket (l/kg/lb): 920 / 820 / 1810 Counterweight (kg/lb): 5000 / 11030				
Description	Shoe width (mm/in)	Operating weight (kg/lb)	Ground pressure (kPa/kgf cm <sup>2</sup> /psi)	Overall width (mm/ft-in)
Triple grouser	500 / 20	23271 / 51310	62.8 / 0.64 / 9.1	2700 / 8' 10"
	600 / 24	23587 / 52010	53.0 / 0.54 / 7.7	2800 / 9' 2"
	700 / 28	24108 / 53160	46.1 / 0.47 / 6.7	2900 / 9' 6"

GP : General Purpose  
 ME : Mass Excavation  
 HD : Heavy Duty



Specifications  
**Ground pressure**      **393**

GP Boom (m/ft-in): 5.7 / 18' 8" HD Arm (m/ft-in): 2.9 / 9' 6" Bucket (l/kg/lb): 920 / 820 / 1810 Counterweight (kg/lb): 5000 / 11030				
Description	Shoe width (mm/in)	Operating weight (kg/lb)	Ground pressure (kPa/kgf cm <sup>2</sup> /psi)	Overall width (mm/ft-in)
Triple grouser	500 / 20	23323 / 51430	62.8 / 0.64 / 9.1	2700 / 8' 10"
	600 / 24	23639 / 52120	53.0 / 0.54 / 7.7	2800 / 9' 2"
	700 / 28	24160 / 53270	46.1 / 0.47 / 6.7	2900 / 9' 6"

GP Boom (m/ft-in): 5.7 / 18' 8" GP Arm (m/ft-in): 3.5 / 11' 6" Bucket (l/kg/lb): 920 / 820 / 1810 Counterweight (kg/lb): 5000 / 11030				
Description	Shoe width (mm/in)	Operating weight (kg/lb)	Ground pressure (kPa/kgf cm <sup>2</sup> /psi)	Overall width (mm/ft-in)
Triple grouser	500 / 20	23836 / 52560	63.7 / 0.65 / 9.2	2700 / 8' 10"
	600 / 24	23702 / 52260	53.0 / 0.54 / 7.7	2800 / 9' 2"
	700 / 28	24224 / 53410	46.1 / 0.47 / 6.7	2900 / 9' 6"

HD Boom (m/ft-in): 5.7 / 18' 8" ME Arm (m/ft-in): 2.0 / 6' 7" Bucket (l/kg/lb): 920 / 820 / 1810 Counterweight (kg/lb): 5000 / 11030				
Description	Shoe width (mm/in)	Operating weight (kg/lb)	Ground pressure (kPa/kgf cm <sup>2</sup> /psi)	Overall width (mm/ft-in)
Triple grouser	500 / 20	23404 / 51610	62.8 / 0.64 / 9.1	2700 / 8' 10"
	600 / 24	23719 / 52300	53.0 / 0.54 / 7.7	2800 / 9' 2"
	700 / 28	24241 / 53450	46.1 / 0.47 / 6.7	2900 / 9' 6"

GP : General Purpose  
 ME : Mass Excavation  
 HD : Heavy Duty



**394**      Specifications  
**Ground pressure**

HD Boom (m/ft-in): 5.7 / 18' 8" HD Arm (m/ft-in): 2.5 / 8' 2" Bucket (l/kg/lb): 920 / 820 / 1810 Counterweight (kg/lb): 5000 / 11030				
Description	Shoe width (mm/in)	Operating weight (kg/lb)	Ground pressure (kPa/kgf cm <sup>2</sup> /psi)	Overall width (mm/ft-in)
Triple grouser	500 / 20	23413 / 51630	62.8 / 0.64 / 9.1	2700 / 8' 10"
	600 / 24	23728 / 52320	53.0 / 0.54 / 7.7	2800 / 9' 2"
	700 / 28	24250 / 53470	46.1 / 0.47 / 6.7	2900 / 9' 6"

HD Boom (m/ft-in): 5.7 / 18' 8" GP Arm (m/ft-in): 2.9 / 9' 6" Bucket (l/kg/lb): 920 / 820 / 1810 Counterweight (kg/lb): 5000 / 11030				
Description	Shoe width (mm/in)	Operating weight (kg/lb)	Ground pressure (kPa/kgf cm <sup>2</sup> /psi)	Overall width (mm/ft-in)
Triple grouser	500 / 20	23417 / 51630	62.8 / 0.64 / 9.1	2700 / 8' 10"
	600 / 24	23733 / 52330	53.0 / 0.54 / 7.7	2800 / 9' 2"
	700 / 28	24255 / 53480	46.1 / 0.47 / 6.7	2900 / 9' 6"

HD Boom (m/ft-in): 5.7 / 18' 8" HD Arm (m/ft-in): 2.9 / 9' 6" Bucket (l/kg/lb): 920 / 820 / 1810 Counterweight (kg/lb): 5000 / 11030				
Description	Shoe width (mm/in)	Operating weight (kg/lb)	Ground pressure (kPa/kgf cm <sup>2</sup> /psi)	Overall width (mm/ft-in)
Triple grouser	500 / 20	23470 / 51750	62.8 / 0.64 / 9.1	2700 / 8' 10"
	600 / 24	23785 / 52450	53.0 / 0.54 / 7.7	2800 / 9' 2"
	700 / 28	24307 / 53600	47.1 / 0.48 / 6.8	2900 / 9' 6"

GP : General Purpose  
 HD : Heavy Duty



Specifications  
**Ground pressure**      **395**

GP Boom (m/ft-in): 5.7 / 18' 8"  
 GP Arm (m/ft-in): 3.5 / 11' 6"  
 Bucket (l/kg/lb): 920 / 820 / 1810  
 Counterweight (kg/lb): 5000 / 11030

Description	Shoe width (mm/in)	Operating weight (kg/lb)	Ground pressure (kPa/kgf cm <sup>2</sup> /psi)	Overall width (mm/ft-in)
Triple grouser	500 / 20	23533 / 51890	62.8 / 0.64 / 9.1	2700 / 8' 10"
	600 / 24	23848 / 52580	53.0 / 0.54 / 7.7	2800 / 9' 2"
	700 / 28	24370 / 53740	47.1 / 0.48 / 6.8	2900 / 9' 6"

VA Boom (m/ft-in): 5.57 / 18' 3"  
 GP Arm (m/ft-in): 2.9 / 9' 6"  
 Bucket (l/kg/lb): 920 / 820 / 1810  
 Counterweight (kg/lb): 5000 / 11030

Description	Shoe width (mm/in)	Operating weight (kg/lb)	Ground pressure (kPa/kgf cm <sup>2</sup> /psi)	Overall width (mm/ft-in)
Triple grouser	500 / 20	23956 / 52820	64.7 / 0.66 / 9.4	2700 / 8' 10"
	600 / 24	24271 / 53520	53.9 / 0.55 / 7.8	2800 / 9' 2"
	700 / 28	24793 / 54670	48.0 / 0.49 / 7.0	2900 / 9' 6"

VA Boom (m/ft-in): 5.57 / 18' 3"  
 HD Arm (m/ft-in): 2.9 / 9' 6"  
 Bucket (l/kg/lb): 920 / 820 / 1810  
 Counterweight (kg/lb): 5000 / 11030

Description	Shoe width (mm/in)	Operating weight (kg/lb)	Ground pressure (kPa/kgf cm <sup>2</sup> /psi)	Overall width (mm/ft-in)
Triple grouser	500 / 20	24008 / 52940	64.7 / 0.66 / 9.4	2700 / 8' 10"
	600 / 24	24323 / 53630	54.9 / 0.56 / 8.0	2800 / 9' 2"
	700 / 28	24845 / 54780	48.0 / 0.49 / 7.0	2900 / 9' 6"

GP : General Purpose  
 VA : Variable Adjustable  
 HD : Heavy Duty



396 Specifications  
Ground pressure

VA Boom (m/ft-in): 5.57 / 18' 3" GP Arm (m/ft-in): 3.5 / 11' 6" Bucket (l/kg/lb): 920 / 820 / 1810 Counterweight (kg/lb): 5000 / 11030				
Description	Shoe width (mm/in)	Operating weight (kg/lb)	Ground pressure (kPa/kgf cm <sup>2</sup> /psi)	Overall width (mm/ft-in)
Triple grouser	500 / 20	24071 / 53080	59.8 / 0.61 / 8.7	2540 / 8' 4"
	600 / 24	24386 / 53770	43.1 / 0.44 / 6.3	2740 / 8' 12"
	700 / 28	24908 / 54920	44.1 / 0.45 / 6.4	2740 / 8' 12"

GP : General Purpose  
VA : Variable Adjustable

EC220E LR

LR Boom (m/ft-in): 8.85 / 29' 0" LR Arm (m/ft-in): 6.25 / 20' 6" Bucket (l/kg/lb): 520 / 452 / 1000 Counterweight (kg/lb): 5000 / 11030				
Description	Shoe width (mm/in)	Operating weight (kg/lb)	Ground pressure (kPa/psi)	Overall width (mm/ft-in)
Triple grouser	800 / 32	23694 / 52250	37.3 / 0.38 / 5.4	3190 / 10' 6"
	900 / 35	23988 / 52890	33.3 / 0.34 / 4.8	3290 / 10' 10"

LR : Long Reach





Specifications  
**Ground pressure**      **397**

For North America

EC220E L

GP Boom (m/ft-in): 5.7 / 18' 8" ME Arm (m/ft-in): 2.0 / 6' 7" Bucket (l/kg/lb): 920 / 860 / 1900 Counterweight (kg/lb): 4200 / 9260				
Description	Shoe width (mm/in)	Operating weight (kg/lb)	Ground pressure (kPa/kgf cm <sup>2</sup> /psi)	Overall width (mm/ft-in)
Triple grouser	500 / 20	21469 / 47340	53.0 / 0.54 / 7.7	2890 / 9' 6"
	600 / 24	21727 / 47910	45.1 / 0.46 / 6.5	2990 / 9' 10"
	600 / 24 (HD)	21895 / 48280	45.1 / 0.46 / 6.5	2990 / 9' 10"
	700 / 28	22186 / 48920	39.2 / 0.4 / 5.7	3090 / 10' 2"
	800 / 32	22471 / 49550	35.3 / 0.36 / 5.1	3190 / 10' 6"
	900 / 35	22765 / 50200	31.4 / 0.32 / 4.6	3290 / 10' 10"
Single grouser	600 / 24	21935 / 48370	45.1 / 0.46 / 6.5	2990 / 9' 10"
Double grouser	700 / 28	22451 / 49500	40.2 / 0.41 / 5.8	3090 / 10' 2"

GP Boom (m/ft-in): 5.7 / 18' 8" HD Arm (m/ft-in): 2.5 / 8' 2" Bucket (l/kg/lb): 920 / 860 / 1900 Counterweight (kg/lb): 4200 / 9260				
Description	Shoe width (mm/in)	Operating weight (kg/lb)	Ground pressure (kPa/kgf cm <sup>2</sup> /psi)	Overall width (mm/ft-in)
Triple grouser	500 / 20	21478 / 47360	53.9 / 0.55 / 7.8	2890 / 9' 6"
	600 / 24	21736 / 47930	45.1 / 0.46 / 6.5	2990 / 9' 10"
	600 / 24 (HD)	21904 / 48300	45.1 / 0.46 / 6.5	2990 / 9' 10"
	700 / 28	22195 / 48940	39.2 / 0.4 / 5.7	3090 / 10' 2"
	800 / 32	22480 / 49570	35.3 / 0.36 / 5.1	3190 / 10' 6"
	900 / 35	22774 / 50220	31.4 / 0.32 / 4.6	3290 / 10' 10"
Single grouser	600 / 24	21944 / 48390	45.1 / 0.46 / 6.5	2990 / 9' 10"
Double grouser	700 / 28	22460 / 49520	40.2 / 0.41 / 5.8	3090 / 10' 2"

GP : General Purpose  
 ME : Mass Excavation  
 HD : Heavy Duty





**398 Specifications**  
**Ground pressure**

GP Boom (m/ft-in): 5.7 / 18' 8" GP Arm (m/ft-in): 2.9 / 9' 6" Bucket (l/kg/lb): 920 / 860 / 1900 Counterweight (kg/lb): 4200 / 9260				
Description	Shoe width (mm/in)	Operating weight (kg/lb)	Ground pressure (kPa/kgf cm <sup>2</sup> /psi)	Overall width (mm/ft-in)
Triple grouser	500 / 20	21482 / 47370	53.9 / 0.55 / 7.8	2890 / 9' 6"
	600 / 24	21740 / 47940	45.1 / 0.46 / 6.5	2990 / 9' 10"
	600 / 24 (HD)	21909 / 48310	45.1 / 0.46 / 6.5	2990 / 9' 10"
	700 / 28	22200 / 48950	39.2 / 0.4 / 5.7	3090 / 10' 2"
	800 / 32	22485 / 49580	35.3 / 0.36 / 5.1	3190 / 10' 6"
	900 / 35	22779 / 50230	31.4 / 0.32 / 4.6	3290 / 10' 10"
Single grouser	600 / 24	21949 / 48400	45.1 / 0.46 / 6.5	2990 / 9' 10"
Double grouser	700 / 28	22465 / 49540	40.2 / 0.41 / 5.8	3090 / 10' 2"

GP Boom (m/ft-in): 5.7 / 18' 8" HD Arm (m/ft-in): 2.9 / 9' 6" Bucket (l/kg/lb): 920 / 860 / 1900 Counterweight (kg/lb): 4200 / 9260				
Description	Shoe width (mm/in)	Operating weight (kg/lb)	Ground pressure (kPa/kgf cm <sup>2</sup> /psi)	Overall width (mm/ft-in)
Triple grouser	500 / 20	21534 / 47480	53.9 / 0.55 / 7.8	2890 / 9' 6"
	600 / 24	21793 / 48050	45.1 / 0.46 / 6.5	2990 / 9' 10"
	600 / 24 (HD)	21961 / 48420	45.1 / 0.46 / 6.5	2990 / 9' 10"
	700 / 28	22252 / 49070	39.2 / 0.4 / 5.7	3090 / 10' 2"
	800 / 32	22537 / 49690	35.3 / 0.36 / 5.1	3190 / 10' 6"
	900 / 35	22831 / 50340	31.4 / 0.32 / 4.6	3290 / 10' 10"
Single grouser	600 / 24	22001 / 48510	46.1 / 0.47 / 6.7	2990 / 9' 10"
Double grouser	700 / 28	22517 / 49650	40.2 / 0.41 / 5.8	3090 / 10' 2"

GP : General Purpose  
 HD : Heavy Duty



Specifications  
**Ground pressure**      **399**

GP Boom (m/ft-in): 5.7 / 18' 8" GP Arm (m/ft-in): 3.5 / 11' 6" Bucket (l/kg/lb): 920 / 860 / 1900 Counterweight (kg/lb): 4200 / 9260				
Description	Shoe width (mm/in)	Operating weight (kg/lb)	Ground pressure (kPa/kgf cm <sup>2</sup> /psi)	Overall width (mm/ft-in)
Triple grouser	500 / 20	21598 / 47620	53.9 / 0.55 / 7.8	2890 / 9' 6"
	600 / 24	21856 / 48190	45.1 / 0.46 / 6.5	2990 / 9' 10"
	600 / 24 (HD)	22024 / 48560	46.1 / 0.47 / 6.7	2990 / 9' 10"
	700 / 28	22315 / 49200	39.2 / 0.4 / 5.7	3090 / 10' 2"
	800 / 32	22600 / 49830	35.3 / 0.36 / 5.1	3190 / 10' 6"
	900 / 35	22894 / 50480	31.4 / 0.32 / 4.6	3290 / 10' 10"
Single grouser	600 / 24	22064 / 48650	46.1 / 0.47 / 6.7	2990 / 9' 10"
Double grouser	700 / 28	22580 / 49790	40.2 / 0.41 / 5.8	3090 / 10' 2"

HD Boom (m/ft-in): 5.7 / 18' 8" ME Arm (m/ft-in): 2.0 / 6' 7" Bucket (l/kg/lb): 920 / 860 / 1900 Counterweight (kg/lb): 4200 / 9260				
Description	Shoe width (mm/in)	Operating weight (kg/lb)	Ground pressure (kPa/kgf cm <sup>2</sup> /psi)	Overall width (mm/ft-in)
Triple grouser	500 / 20	21615 / 47660	53.9 / 0.55 / 7.8	2890 / 9' 6"
	600 / 24	21873 / 48230	45.1 / 0.46 / 6.5	2990 / 9' 10"
	600 / 24 (HD)	22041 / 48600	46.1 / 0.47 / 6.7	2990 / 9' 10"
	700 / 28	22332 / 49240	39.2 / 0.4 / 5.7	3090 / 10' 2"
	800 / 32	22617 / 49870	35.3 / 0.36 / 5.1	3190 / 10' 6"
	900 / 35	22911 / 50520	31.4 / 0.32 / 4.6	3290 / 10' 10"
Single grouser	600 / 24	22081 / 48690	46.1 / 0.47 / 6.7	2990 / 9' 10"
Double grouser	700 / 28	22597 / 49830	40.2 / 0.41 / 5.8	3090 / 10' 2"

GP : General Purpose  
 ME : Mass Excavation  
 HD : Heavy Duty



**400 Specifications**  
**Ground pressure**

HD Boom (m/ft-in): 5.7 / 18' 8" HD Arm (m/ft-in): 2.5 / 8' 2" Bucket (l/kg/lb): 920 / 860 / 1900 Counterweight (kg/lb): 4200 / 9260				
Description	Shoe width (mm/in)	Operating weight (kg/lb)	Ground pressure (kPa/kgf cm <sup>2</sup> /psi)	Overall width (mm/ft-in)
Triple grouser	500 / 20	21624 / 47680	53.9 / 0.55 / 7.8	2890 / 9' 6"
	600 / 24	21882 / 48250	45.1 / 0.46 / 6.5	2990 / 9' 10"
	600 / 24 (HD)	22050 / 48620	46.1 / 0.47 / 6.7	2990 / 9' 10"
	700 / 28	22341 / 49260	39.2 / 0.4 / 5.7	3090 / 10' 2"
	800 / 32	22626 / 49890	35.3 / 0.36 / 5.1	3190 / 10' 6"
	900 / 35	22920 / 50540	31.4 / 0.32 / 4.6	3290 / 10' 10"
Single grouser	600 / 24	22090 / 48710	46.1 / 0.47 / 6.7	2990 / 9' 10"
Double grouser	700 / 28	22607 / 49850	40.2 / 0.41 / 5.8	3090 / 10' 2"

HD Boom (m/ft-in): 5.7 / 18' 8" GP Arm (m/ft-in): 2.9 / 9' 6" Bucket (l/kg/lb): 920 / 860 / 1900 Counterweight (kg/lb): 4200 / 9260				
Description	Shoe width (mm/in)	Operating weight (kg/lb)	Ground pressure (kPa/kgf cm <sup>2</sup> /psi)	Overall width (mm/ft-in)
Triple grouser	500 / 20	21629 / 47690	53.9 / 0.55 / 7.8	2890 / 9' 6"
	600 / 24	21887 / 48260	45.1 / 0.46 / 6.5	2990 / 9' 10"
	600 / 24 (HD)	22055 / 48630	46.1 / 0.47 / 6.7	2990 / 9' 10"
	700 / 28	22346 / 49270	40.2 / 0.41 / 5.8	3090 / 10' 2"
	800 / 32	22631 / 49900	35.3 / 0.36 / 5.1	3190 / 10' 6"
	900 / 35	22925 / 50550	31.4 / 0.32 / 4.6	3290 / 10' 10"
Single grouser	600 / 24	22095 / 48720	46.1 / 0.47 / 6.7	2990 / 9' 10"
Double grouser	700 / 28	22611 / 49860	40.2 / 0.41 / 5.8	3090 / 10' 2"

GP : General Purpose  
 HD : Heavy Duty



Specifications  
**Ground pressure**      **401**

HD Boom (m/ft-in): 5.7 / 18' 8" HD Arm (m/ft-in): 2.9 / 9' 6" Bucket (l/kg/lb): 920 / 860 / 1900 Counterweight (kg/lb): 4200 / 9260				
Description	Shoe width (mm/in)	Operating weight (kg/lb)	Ground pressure (kPa/kgf cm <sup>2</sup> /psi)	Overall width (mm/ft-in)
Triple grouser	500 / 20	21681 / 47810	53.9 / 0.55 / 7.8	2890 / 9' 6"
	600 / 24	21939 / 48380	45.1 / 0.46 / 6.5	2990 / 9' 10"
	600 / 24 (HD)	22107 / 48750	46.1 / 0.47 / 6.7	2990 / 9' 10"
	700 / 28	22398 / 49390	40.2 / 0.41 / 5.8	3090 / 10' 2"
	800 / 32	22683 / 50020	35.3 / 0.36 / 5.1	3190 / 10' 6"
	900 / 35	22977 / 50660	31.4 / 0.32 / 4.6	3290 / 10' 10"
Single grouser	600 / 24	22147 / 48830	46.1 / 0.47 / 6.7	2990 / 9' 10"
Double grouser	700 / 28	22663 / 49970	40.2 / 0.41 / 5.8	3090 / 10' 2"

HD Boom (m/ft-in): 5.7 / 18' 8" GP Arm (m/ft-in): 3.5 / 11' 6" Bucket (l/kg/lb): 920 / 860 / 1900 Counterweight (kg/lb): 4200 / 9260				
Description	Shoe width (mm/in)	Operating weight (kg/lb)	Ground pressure (kPa/kgf cm <sup>2</sup> /psi)	Overall width (mm/ft-in)
Triple grouser	500 / 20	21744 / 47950	53.9 / 0.55 / 7.8	2890 / 9' 6"
	600 / 24	22002 / 48510	46.1 / 0.47 / 6.7	2990 / 9' 10"
	600 / 24 (HD)	22170 / 48880	46.1 / 0.47 / 6.7	2990 / 9' 10"
	700 / 28	22461 / 49530	40.2 / 0.41 / 5.8	3090 / 10' 2"
	800 / 32	22746 / 50150	35.3 / 0.36 / 5.1	3190 / 10' 6"
	900 / 35	23040 / 50800	31.4 / 0.32 / 4.6	3290 / 10' 10"
Single grouser	600 / 24	22210 / 48970	46.1 / 0.47 / 6.7	2990 / 9' 10"
Double grouser	700 / 28	22727 / 50110	40.2 / 0.41 / 5.8	3090 / 10' 2"

GP : General Purpose

HD : Heavy Duty



Specifications  
402 Ground pressure

VA Boom (m/ft-in): 5.57 / 18' 3" GP Arm (m/ft-in): 2.9 / 9' 6" Bucket (l/kg/lb): 920 / 860 / 1900 Counterweight (kg/lb): 4200 / 9260				
Description	Shoe width (mm/in)	Operating weight (kg/lb)	Ground pressure (kPa/kgf cm <sup>2</sup> /psi)	Overall width (mm/ft-in)
Triple grouser	500 / 20	22167 / 48880	54.9 / 0.56 / 8.0	2890 / 9' 6"
	600 / 24	22425 / 49450	46.1 / 0.47 / 6.7	2990 / 9' 10"
	600 / 24 (HD)	22593 / 49820	47.1 / 0.48 / 6.8	2990 / 9' 10"
	700 / 28	22884 / 50460	40.2 / 0.41 / 5.8	3090 / 10' 2"
	800 / 32	23169 / 51090	36.3 / 0.37 / 5.3	3190 / 10' 6"
	900 / 35	23463 / 51740	32.4 / 0.33 / 4.7	3290 / 10' 10"
Single grouser	600 / 24	22633 / 49910	47.1 / 0.48 / 6.8	2990 / 9' 10"
Double grouser	700 / 28	23150 / 51050	41.2 / 0.42 / 6.0	3090 / 10' 2"

VA Boom (m/ft-in): 5.57 / 18' 3" HD Arm (m/ft-in): 2.9 / 9' 6" Bucket (l/kg/lb): 920 / 860 / 1900 Counterweight (kg/lb): 4200 / 9260				
Description	Shoe width (mm/in)	Operating weight (kg/lb)	Ground pressure (kPa/kgf cm <sup>2</sup> /psi)	Overall width (mm/ft-in)
Triple grouser	500 / 20	22219 / 48990	54.9 / 0.56 / 8.0	2890 / 9' 6"
	600 / 24	22477 / 49560	47.1 / 0.48 / 6.8	2990 / 9' 10"
	600 / 24 (HD)	22645 / 49930	47.1 / 0.48 / 6.8	2990 / 9' 10"
	700 / 28	22936 / 50570	41.2 / 0.42 / 6.0	3090 / 10' 2"
	800 / 32	23221 / 51200	36.3 / 0.37 / 5.3	3190 / 10' 6"
	900 / 35	23518 / 51860	32.4 / 0.33 / 4.7	3290 / 10' 10"
Single grouser	600 / 24	22685 / 50020	47.1 / 0.48 / 6.8	2990 / 9' 10"
Double grouser	700 / 28	23202 / 51160	41.2 / 0.42 / 6.0	3090 / 10' 2"

GP : General Purpose  
 VA : Variable Adjustable  
 HD : Heavy Duty



Specifications  
Ground pressure **403**

VA Boom (m/ft-in): 5.57 / 18' 3" GP Arm (m/ft-in): 3.5 / 11' 6" Bucket (l/kg/lb): 920 / 860 / 1900 Counterweight (kg/lb): 4200 / 9260				
Description	Shoe width (mm/in)	Operating weight (kg/lb)	Ground pressure (kPa/kgf cm <sup>2</sup> /psi)	Overall width (mm/ft-in)
Triple grouser	500 / 20	22282 / 49130	55.9 / 0.57 / 8.1	2890 / 9' 6"
	600 / 24	22540 / 49700	47.1 / 0.48 / 6.8	2990 / 9' 10"
	600 / 24 (HD)	22708 / 50070	47.1 / 0.48 / 6.8	2990 / 9' 10"
	700 / 28	22999 / 50710	41.2 / 0.42 / 6.0	3090 / 10' 2"
	800 / 32	23284 / 51340	36.3 / 0.37 / 5.3	3190 / 10' 6"
	900 / 35	23578 / 51990	32.4 / 0.33 / 4.7	3290 / 10' 10"
Single grouser	600 / 24	22748 / 50160	47.1 / 0.48 / 6.8	2990 / 9' 10"
Double grouser	700 / 28	23265 / 51300	41.2 / 0.42 / 6.0	3090 / 10' 2"

GP : General Purpose  
 VA : Variable Adjustable  
 HD : Heavy Duty



404 Specifications  
Ground pressure

EC220E NL

GP Boom (m/ft-in): 5.7 / 18' 8" ME Arm (m/ft-in): 2.0 / 6' 7" Bucket (l/kg/lb): 920 / 860 / 1900 Counterweight (kg/lb): 5000 / 11030				
Description	Shoe width (mm/in)	Operating weight (kg/lb)	Ground pressure (kPa/kgf cm <sup>2</sup> /psi)	Overall width (mm/ft-in)
Triple grouser	500 / 20	22181 / 48910	54.9 / 0.56 / 8.0	2540 / 8' 4"
	600 / 24	22439 / 49480	46.1 / 0.47 / 6.7	2640 / 8' 8"
	600 / 24 (HD)	22607 / 49850	47.1 / 0.48 / 6.8	2640 / 8' 8"
	700 / 28	22898 / 50490	41.2 / 0.42 / 6.0	2740 / 8' 12"
Double grouser	700 / 28	23163 / 51070	41.2 / 0.42 / 6.0	2740 / 8' 12"

GP Boom (m/ft-in): 5.7 / 18' 8" HD Arm (m/ft-in): 2.5 / 8' 2" Bucket (l/kg/lb): 920 / 860 / 1900 Counterweight (kg/lb): 5000 / 11030				
Description	Shoe width (mm/in)	Operating weight (kg/lb)	Ground pressure (kPa/kgf cm <sup>2</sup> /psi)	Overall width (mm/ft-in)
Triple grouser	500 / 20	22190 / 48930	54.9 / 0.56 / 8.0	2540 / 8' 4"
	600 / 24	22448 / 49500	46.1 / 0.47 / 6.7	2640 / 8' 8"
	600 / 24 (HD)	22616 / 49870	47.1 / 0.48 / 6.8	2640 / 8' 8"
	700 / 28	22907 / 50510	41.2 / 0.42 / 6.0	2740 / 8' 12"
Double grouser	700 / 28	23172 / 51090	41.2 / 0.42 / 6.0	2740 / 8' 12"

GP : General Purpose  
 ME : Mass Excavation  
 HD : Heavy Duty





Specifications  
**Ground pressure**      **405**

GP Boom (m/ft-in): 5.7 / 18' 8"  
 GP Arm (m/ft-in): 2.9 / 9' 6"  
 Bucket (l/kg/lb): 920 / 860 / 1900  
 Counterweight (kg/lb): 5000 / 11030

Description	Shoe width (mm/in)	Operating weight (kg/lb)	Ground pressure (kPa/kgf cm <sup>2</sup> /psi)	Overall width (mm/ft-in)
Triple grouser	500 / 20	22194 / 48940	54.9 / 0.56 / 8.0	2540 / 8' 4"
	600 / 24	22453 / 49510	46.1 / 0.47 / 6.7	2640 / 8' 8"
	600 / 24 (HD)	22621 / 49880	47.1 / 0.48 / 6.8	2640 / 8' 8"
	700 / 28	22912 / 50520	41.2 / 0.42 / 6.0	2740 / 8' 12"
Double grouser	700 / 28	23177 / 51110	41.2 / 0.42 / 6.0	2740 / 8' 12"

GP Boom (m/ft-in): 5.7 / 18' 8"  
 HD Arm (m/ft-in): 2.9 / 9' 6"  
 Bucket (l/kg/lb): 920 / 860 / 1900  
 Counterweight (kg/lb): 5000 / 11030

Description	Shoe width (mm/in)	Operating weight (kg/lb)	Ground pressure (kPa/kgf cm <sup>2</sup> /psi)	Overall width (mm/ft-in)
Triple grouser	500 / 20	22247 / 49050	54.9 / 0.56 / 8.0	2540 / 8' 4"
	600 / 24	22505 / 49620	47.1 / 0.48 / 6.8	2640 / 8' 8"
	600 / 24 (HD)	22673 / 49990	47.1 / 0.48 / 6.8	2640 / 8' 8"
	700 / 28	22964 / 50640	41.2 / 0.42 / 6.0	2740 / 8' 12"
Double grouser	700 / 28	23229 / 51220	41.2 / 0.42 / 6.0	2740 / 8' 12"

GP : General Purpose  
 HD : Heavy Duty





406 Specifications  
Ground pressure

GP Boom (m/ft-in): 5.7 / 18' 8" GP Arm (m/ft-in): 3.5 / 11' 6" Bucket (l/kg/lb): 920 / 860 / 1900 Counterweight (kg/lb): 5000 / 11030				
Description	Shoe width (mm/in)	Operating weight (kg/lb)	Ground pressure (kPa/kgf cm <sup>2</sup> /psi)	Overall width (mm/ft-in)
Triple grouser	500 / 20	22310 / 49190	55.9 / 0.57 / 8.1	2540 / 8' 4"
	600 / 24	22568 / 49760	47.1 / 0.48 / 6.8	2640 / 8' 8"
	600 / 24 (HD)	22736 / 50130	47.1 / 0.48 / 6.8	2640 / 8' 8"
	700 / 28	23027 / 50770	41.2 / 0.42 / 6.0	2740 / 8' 12"
Double grouser	700 / 28	23292 / 51360	41.2 / 0.42 / 6.0	2740 / 8' 12"

HD Boom (m/ft-in): 5.7 / 18' 8" ME Arm (m/ft-in): 2.0 / 6' 7" Bucket (l/kg/lb): 920 / 860 / 1900 Counterweight (kg/lb): 5000 / 11030				
Description	Shoe width (mm/in)	Operating weight (kg/lb)	Ground pressure (kPa/kgf cm <sup>2</sup> /psi)	Overall width (mm/ft-in)
Triple grouser	500 / 20	22327 / 49230	55.9 / 0.57 / 8.1	2540 / 8' 4"
	600 / 24	22585 / 49800	47.1 / 0.48 / 6.8	2640 / 8' 8"
	600 / 24 (HD)	22753 / 50170	47.1 / 0.48 / 6.8	2640 / 8' 8"
	700 / 28	23044 / 50810	41.2 / 0.42 / 6.0	2740 / 8' 12"
Double grouser	700 / 28	23310 / 51400	41.2 / 0.42 / 6.0	2740 / 8' 12"

GP : General Purpose  
 ME : Mass Excavation  
 HD : Heavy Duty



Specifications  
**Ground pressure**      **407**

HD Boom (m/ft-in): 5.7 / 18' 8"  
 HD Arm (m/ft-in): 2.5 / 8' 2"  
 Bucket (l/kg/lb): 920 / 860 / 1900  
 Counterweight (kg/lb): 5000 / 11030

Description	Shoe width (mm/in)	Operating weight (kg/lb)	Ground pressure (kPa/kgf cm <sup>2</sup> /psi)	Overall width (mm/ft-in)
Triple grouser	500 / 20	22336 / 49250	55.9 / 0.57 / 8.1	2540 / 8' 4"
	600 / 24	22594 / 49820	47.1 / 0.48 / 6.8	2640 / 8' 8"
	600 / 24 (HD)	22762 / 50190	47.1 / 0.48 / 6.8	2640 / 8' 8"
	700 / 28	23053 / 50830	41.2 / 0.42 / 6.0	2740 / 8' 12"
Double grouser	700 / 28	23319 / 51420	41.2 / 0.42 / 6.0	2740 / 8' 12"

HD Boom (m/ft-in): 5.7 / 18' 8"  
 GP Arm (m/ft-in): 2.9 / 9' 6"  
 Bucket (l/kg/lb): 920 / 860 / 1900  
 Counterweight (kg/lb): 5000 / 11030

Description	Shoe width (mm/in)	Operating weight (kg/lb)	Ground pressure (kPa/kgf cm <sup>2</sup> /psi)	Overall width (mm/ft-in)
Triple grouser	500 / 20	22341 / 49260	55.9 / 0.57 / 8.1	2540 / 8' 4"
	600 / 24	22599 / 49830	47.1 / 0.48 / 6.8	2640 / 8' 8"
	600 / 24 (HD)	22767 / 50200	47.1 / 0.48 / 6.8	2640 / 8' 8"
	700 / 28	23058 / 50840	41.2 / 0.42 / 6.0	2740 / 8' 12"
Double grouser	700 / 28	23323 / 51430	41.2 / 0.42 / 6.0	2740 / 8' 12"

GP : General Purpose  
 HD : Heavy Duty



**408 Specifications**  
**Ground pressure**

HD Boom (m/ft-in): 5.7 / 18' 8" HD Arm (m/ft-in): 2.9 / 9' 6" Bucket (l/kg/lb): 920 / 860 / 1900 Counterweight (kg/lb): 5000 / 11030				
Description	Shoe width (mm/in)	Operating weight (kg/lb)	Ground pressure (kPa/kgf cm <sup>2</sup> /psi)	Overall width (mm/ft-in)
Triple grouser	500 / 20	22393 / 49380	55.9 / 0.57 / 8.1	2540 / 8' 4"
	600 / 24	22651 / 49950	47.1 / 0.48 / 6.8	2640 / 8' 8"
	600 / 24 (HD)	22819 / 50320	47.1 / 0.48 / 6.8	2640 / 8' 8"
	700 / 28	23110 / 50960	41.2 / 0.42 / 6.0	2740 / 8' 12"
Double grouser	700 / 28	23376 / 51540	41.2 / 0.42 / 6.0	2740 / 8' 12"

GP Boom (m/ft-in): 5.7 / 18' 8" GP Arm (m/ft-in): 3.5 / 11' 6" Bucket (l/kg/lb): 920 / 860 / 1900 Counterweight (kg/lb): 5000 / 11030				
Description	Shoe width (mm/in)	Operating weight (kg/lb)	Ground pressure (kPa/kgf cm <sup>2</sup> /psi)	Overall width (mm/ft-in)
Triple grouser	500 / 20	22456 / 49520	55.9 / 0.57 / 8.1	2540 / 8' 4"
	600 / 24	22714 / 50080	47.1 / 0.48 / 6.8	2640 / 8' 8"
	600 / 24 (HD)	22882 / 50450	47.1 / 0.48 / 6.8	2640 / 8' 8"
	700 / 28	23173 / 51100	41.2 / 0.42 / 6.0	2740 / 8' 12"
Double grouser	700 / 28	23439 / 51680	41.2 / 0.42 / 6.0	2740 / 8' 12"

GP : General Purpose  
 HD : Heavy Duty



Specifications  
**Ground pressure**      **409**

VA Boom (m/ft-in): 5.57 / 18' 3"  
 GP Arm (m/ft-in): 2.9 / 9' 6"  
 Bucket (l/kg/lb): 920 / 860 / 1900  
 Counterweight (kg/lb): 5000 / 11030

Description	Shoe width (mm/in)	Operating weight (kg/lb)	Ground pressure (kPa/kgf cm <sup>2</sup> /psi)	Overall width (mm/ft-in)
Triple grouser	500 / 20	22879 / 50450	56.9 / 0.58 / 8.2	2540 / 8' 4"
	600 / 24	23137 / 51020	48.0 / 0.49 / 7.0	2640 / 8' 8"
	600 / 24 (HD)	23305 / 51390	48.0 / 0.49 / 7.0	2640 / 8' 8"
	700 / 28	23596 / 52030	42.2 / 0.43 / 6.1	2740 / 8' 12"
Double grouser	700 / 28	23862 / 52620	42.2 / 0.43 / 6.1	2740 / 8' 12"

VA Boom (m/ft-in): 5.57 / 18' 3"  
 HD Arm (m/ft-in): 2.9 / 9' 6"  
 Bucket (l/kg/lb): 920 / 860 / 1900  
 Counterweight (kg/lb): 5000 / 11030

Description	Shoe width (mm/in)	Operating weight (kg/lb)	Ground pressure (kPa/kgf cm <sup>2</sup> /psi)	Overall width (mm/ft-in)
Triple grouser	500 / 20	22931 / 50560	56.9 / 0.58 / 8.2	2540 / 8' 4"
	600 / 24	23189 / 51130	48.0 / 0.49 / 7.0	2640 / 8' 8"
	600 / 24 (HD)	23357 / 51500	48.0 / 0.49 / 7.0	2640 / 8' 8"
	700 / 28	23648 / 52140	42.2 / 0.43 / 6.1	2740 / 8' 12"
Double grouser	700 / 28	23914 / 52730	42.2 / 0.43 / 6.1	2740 / 8' 12"

GP : General Purpose  
 VA : Variable Adjustable  
 HD : Heavy Duty



Specifications  
410 Ground pressure

VA Boom (m/ft-in): 5.57 / 18' 3" GP Arm (m/ft-in): 3.5 / 11' 6" Bucket (l/kg/lb): 920 / 860 / 1900 Counterweight (kg/lb): 5000 / 11030				
Description	Shoe width (mm/in)	Operating weight (kg/lb)	Ground pressure (kPa/kgf cm <sup>2</sup> /psi)	Overall width (mm/ft-in)
Triple grouser	500 / 20	22994 / 50700	56.9 / 0.58 / 8.2	2540 / 8' 4"
	600 / 24	23252 / 51270	48.0 / 0.49 / 7.0	2640 / 8' 8"
	600 / 24 (HD)	23420 / 51640	49.0 / 0.5 / 7.1	2640 / 8' 8"
	700 / 28	23711 / 52280	42.2 / 0.43 / 6.1	2740 / 8' 12"
Double grouser	700 / 28	23977 / 52870	42.2 / 0.43 / 6.1	2740 / 8' 12"

GP : General Purpose  
 VA : Variable Adjustable  
 HD : Heavy Duty



Specifications  
**Ground pressure**      **411**

**EC220E N**

GP Boom (m/ft-in): 5.7 / 18' 8" ME Arm (m/ft-in): 2.0 / 6' 7" Bucket (l/kg/lb): 920 / 860 / 1900 Counterweight (kg/lb): 4200 / 9260				
Description	Shoe width (mm/in)	Operating weight (kg/lb)	Ground pressure (kPa/kgf cm <sup>2</sup> /psi)	Overall width (mm/ft-in)
Triple grouser	600 / 24	21305 / 46980	48.0 / 0.49 / 7.0	2800 / 9' 2"
	600 / 24 (HD)	21463 / 47330	48.0 / 0.49 / 7.0	2800 / 9' 2"
	700 / 28	21737 / 47930	42.2 / 0.43 / 6.1	2900 / 9' 6"
	800 / 32	22005 / 48520	37.3 / 0.38 / 5.4	3000 / 9' 10"
	900 / 35	22281 / 49130	33.3 / 0.34 / 4.8	3100 / 10' 2"

GP Boom (m/ft-in): 5.7 / 18' 8" HD Arm (m/ft-in): 2.5 / 8' 2" Bucket (l/kg/lb): 920 / 860 / 1900 Counterweight (kg/lb): 4200 / 9260				
Description	Shoe width (mm/in)	Operating weight (kg/lb)	Ground pressure (kPa/kgf cm <sup>2</sup> /psi)	Overall width (mm/ft-in)
Triple grouser	600 / 24	21315 / 47000	48.0 / 0.49 / 7.0	2800 / 9' 2"
	600 / 24 (HD)	21473 / 47350	48.0 / 0.49 / 7.0	2800 / 9' 2"
	700 / 28	21746 / 47950	42.2 / 0.43 / 6.1	2900 / 9' 6"
	800 / 32	22014 / 48540	37.3 / 0.38 / 5.4	3000 / 9' 10"
	900 / 35	22252 / 49070	33.3 / 0.34 / 4.8	3100 / 10' 2"

GP : General Purpose  
 ME : Mass Excavation  
 HD : Heavy Duty



Specifications  
412 Ground pressure

GP Boom (m/ft-in): 5.7 / 18' 8"  
 GP Arm (m/ft-in): 2.9 / 9' 6"  
 Bucket (l/kg/lb): 920 / 860 / 1900  
 Counterweight (kg/lb): 4200 / 9260

Description	Shoe width (mm/in)	Operating weight (kg/lb)	Ground pressure (kPa/kgf cm <sup>2</sup> /psi)	Overall width (mm/ft-in)
Triple grouser	600 / 24	21319 / 47010	48.0 / 0.49 / 7.0	2800 / 9' 2"
	600 / 24 (HD)	21477 / 47360	48.0 / 0.49 / 7.0	2800 / 9' 2"
	700 / 28	21751 / 47960	42.2 / 0.43 / 6.1	2900 / 9' 6"
	800 / 32	22019 / 48550	37.3 / 0.38 / 5.4	3000 / 9' 10"
	900 / 35	22256 / 49070	33.3 / 0.34 / 4.8	3100 / 10' 2"

GP Boom (m/ft-in): 5.7 / 18' 8"  
 HD Arm (m/ft-in): 2.9 / 9' 6"  
 Bucket (l/kg/lb): 920 / 860 / 1900  
 Counterweight (kg/lb): 4200 / 9260

Description	Shoe width (mm/in)	Operating weight (kg/lb)	Ground pressure (kPa/kgf cm <sup>2</sup> /psi)	Overall width (mm/ft-in)
Triple grouser	600 / 24	21371 / 47120	48.0 / 0.49 / 7.0	2800 / 9' 2"
	600 / 24 (HD)	21529 / 47470	48.0 / 0.49 / 7.0	2800 / 9' 2"
	700 / 28	21803 / 48080	42.2 / 0.43 / 6.1	2900 / 9' 6"
	800 / 32	22071 / 48670	37.3 / 0.38 / 5.4	3000 / 9' 10"
	900 / 35	22308 / 49190	33.3 / 0.34 / 4.8	3100 / 10' 2"

GP : General Purpose  
 HD : Heavy Duty



Specifications  
**Ground pressure**      **413**

GP Boom (m/ft-in): 5.7 / 18' 8"  
 GP Arm (m/ft-in): 3.5 / 11' 6"  
 Bucket (l/kg/lb): 920 / 860 / 1900  
 Counterweight (kg/lb): 4200 / 9260

Description	Shoe width (mm/in)	Operating weight (kg/lb)	Ground pressure (kPa/kgf cm <sup>2</sup> /psi)	Overall width (mm/ft-in)
Triple grouser	600 / 24	21434 / 47260	48.0 / 0.49 / 7.0	2800 / 9' 2"
	600 / 24 (HD)	21592 / 47610	48.0 / 0.49 / 7.0	2800 / 9' 2"
	700 / 28	21866 / 48210	42.2 / 0.43 / 6.1	2900 / 9' 6"
	800 / 32	22134 / 48810	37.3 / 0.38 / 5.4	3000 / 9' 10"
	900 / 35	22372 / 49330	33.3 / 0.34 / 4.8	3100 / 10' 2"

HD Boom (m/ft-in): 5.7 / 18' 8"  
 ME Arm (m/ft-in): 2.0 / 6' 7"  
 Bucket (l/kg/lb): 920 / 860 / 1900  
 Counterweight (kg/lb): 4200 / 9260

Description	Shoe width (mm/in)	Operating weight (kg/lb)	Ground pressure (kPa/kgf cm <sup>2</sup> /psi)	Overall width (mm/ft-in)
Triple grouser	600 / 24	21452 / 47300	48.0 / 0.49 / 7.0	2800 / 9' 2"
	600 / 24 (HD)	21610 / 47650	48.0 / 0.49 / 7.0	2800 / 9' 2"
	700 / 28	21883 / 48250	42.2 / 0.43 / 6.1	2900 / 9' 6"
	800 / 32	22151 / 48840	37.3 / 0.38 / 5.4	3000 / 9' 10"
	900 / 35	22389 / 49370	33.3 / 0.34 / 4.8	3100 / 10' 2"

GP : General Purpose  
 ME : Mass Excavation  
 HD : Heavy Duty





**414 Specifications**  
**Ground pressure**

HD Boom (m/ft-in): 5.7 / 18' 8" HD Arm (m/ft-in): 2.5 / 8' 2" Bucket (l/kg/lb): 920 / 860 / 1900 Counterweight (kg/lb): 4200 / 9260				
Description	Shoe width (mm/in)	Operating weight (kg/lb)	Ground pressure (kPa/kgf cm <sup>2</sup> /psi)	Overall width (mm/ft-in)
Triple grouser	600 / 24	21461 / 47320	48.0 / 0.49 / 7.0	2800 / 9' 2"
	600 / 24 (HD)	21619 / 47670	48.0 / 0.49 / 7.0	2800 / 9' 2"
	700 / 28	21892 / 48270	42.2 / 0.43 / 6.1	2900 / 9' 6"
	800 / 32	22160 / 48860	37.3 / 0.38 / 5.4	3000 / 9' 10"
	900 / 35	22389 / 49370	33.3 / 0.34 / 4.8	3100 / 10' 2"

HD Boom (m/ft-in): 5.7 / 18' 8" GP Arm (m/ft-in): 2.9 / 9' 6" Bucket (l/kg/lb): 920 / 860 / 1900 Counterweight (kg/lb): 4200 / 9260				
Description	Shoe width (mm/in)	Operating weight (kg/lb)	Ground pressure (kPa/kgf cm <sup>2</sup> /psi)	Overall width (mm/ft-in)
Triple grouser	600 / 24	21465 / 47330	48.0 / 0.49 / 7.0	2800 / 9' 2"
	600 / 24 (HD)	21624 / 47680	48.0 / 0.49 / 7.0	2800 / 9' 2"
	700 / 28	21892 / 48270	42.2 / 0.43 / 6.1	2900 / 9' 6"
	800 / 32	22160 / 48860	37.3 / 0.38 / 5.4	3000 / 9' 10"
	900 / 35	22398 / 49390	33.3 / 0.34 / 4.8	3100 / 10' 2"

GP : General Purpose  
 HD : Heavy Duty



Specifications  
**Ground pressure 415**

HD Boom (m/ft-in): 5.7 / 18' 8"  
 HD Arm (m/ft-in): 2.9 / 9' 6"  
 Bucket (l/kg/lb): 920 / 860 / 1900  
 Counterweight (kg/lb): 4200 / 9260

Description	Shoe width (mm/in)	Operating weight (kg/lb)	Ground pressure (kPa/kgf cm <sup>2</sup> /psi)	Overall width (mm/ft-in)
Triple grouser	600 / 24	21518 / 47450	48.0 / 0.49 / 7.0	2800 / 9' 2"
	600 / 24 (HD)	21676 / 47800	48.0 / 0.49 / 7.0	2800 / 9' 2"
	700 / 28	21949 / 48400	42.2 / 0.43 / 6.1	2900 / 9' 6"
	800 / 32	22217 / 48990	37.3 / 0.38 / 5.4	3000 / 9' 10"
	900 / 35	22455 / 49510	33.3 / 0.34 / 4.8	3100 / 10' 2"

GP Boom (m/ft-in): 5.7 / 18' 8"  
 GP Arm (m/ft-in): 3.5 / 11' 6"  
 Bucket (l/kg/lb): 920 / 860 / 1900  
 Counterweight (kg/lb): 4200 / 9260

Description	Shoe width (mm/in)	Operating weight (kg/lb)	Ground pressure (kPa/kgf cm <sup>2</sup> /psi)	Overall width (mm/ft-in)
Triple grouser	600 / 24	21581 / 47590	48.0 / 0.49 / 7.0	2800 / 9' 2"
	600 / 24 (HD)	21739 / 47930	49.0 / 0.5 / 7.1	2800 / 9' 2"
	700 / 28	21949 / 48400	42.2 / 0.43 / 6.1	2900 / 9' 6"
	800 / 32	22217 / 48990	37.3 / 0.38 / 5.4	3000 / 9' 10"
	900 / 35	22455 / 49510	33.3 / 0.34 / 4.8	3100 / 10' 2"

GP : General Purpose  
 HD : Heavy Duty



**416**      Specifications  
**Ground pressure**

VA Boom (m/ft-in): 5.57 / 18' 3" GP Arm (m/ft-in): 2.9 / 9' 6" Bucket (l/kg/lb): 920 / 860 / 1900 Counterweight (kg/lb): 4200 / 9260				
Description	Shoe width (mm/in)	Operating weight (kg/lb)	Ground pressure (kPa/kgf cm <sup>2</sup> /psi)	Overall width (mm/ft-in)
Triple grouser	600 / 24	22004 / 48520	49.0 / 0.5 / 7.1	2800 / 9' 2"
	600 / 24 (HD)	22162 / 48870	50.0 / 0.51 / 7.3	2800 / 9' 2"
	700 / 28	22435 / 49470	43.1 / 0.44 / 6.3	2900 / 9' 6"
	800 / 32	22703 / 50060	38.2 / 0.39 / 5.5	3000 / 9' 10"
	900 / 35	22941 / 50580	34.3 / 0.35 / 5.0	3100 / 10' 2"

VA Boom (m/ft-in): 5.57 / 18' 3" HD Arm (m/ft-in): 2.9 / 9' 6" Bucket (l/kg/lb): 920 / 860 / 1900 Counterweight (kg/lb): 4200 / 9260				
Description	Shoe width (mm/in)	Operating weight (kg/lb)	Ground pressure (kPa/kgf cm <sup>2</sup> /psi)	Overall width (mm/ft-in)
Triple grouser	600 / 24	22056 / 48630	49.0 / 0.5 / 7.1	2800 / 9' 2"
	600 / 24 (HD)	22214 / 48980	50.0 / 0.51 / 7.3	2800 / 9' 2"
	700 / 28	22487 / 49580	43.1 / 0.44 / 6.3	2900 / 9' 6"
	800 / 32	22755 / 50170	38.2 / 0.39 / 5.5	3000 / 9' 10"
	900 / 35	22993 / 50700	34.3 / 0.35 / 5.0	3100 / 10' 2"

GP : General Purpose  
 VA : Variable Adjustable  
 HD : Heavy Duty



Specifications  
**Ground pressure 417**

VA Boom (m/ft-in): 5.57 / 18' 3" GP Arm (m/ft-in): 3.5 / 11' 6" Bucket (l/kg/lb): 920 / 860 / 1900 Counterweight (kg/lb): 4200 / 9260				
Description	Shoe width (mm/in)	Operating weight (kg/lb)	Ground pressure (kPa/kgf cm <sup>2</sup> /psi)	Overall width (mm/ft-in)
Triple grouser	500 / 20	22119 / 48770	54.9 / 0.56 / 8.0	2540 / 8' 4"
	600 / 24	22277 / 49120	46.1 / 0.47 / 6.7	2640 / 8' 8"
	600 / 24 (HD)	22550 / 49720	47.1 / 0.48 / 6.8	2640 / 8' 8"
	700 / 28	22818 / 50310	40.2 / 0.41 / 5.8	2740 / 8' 12"
Double grouser	700 / 28	23056 / 50840	41.2 / 0.42 / 6.0	2740 / 8' 12"

VA : Variable Adjustable  
 HD : Heavy Duty

**EC220E LR**

LR Boom (m/ft-in): 8.85 / 29' 0" LR Arm (m/ft-in): 6.25 / 20' 6" Bucket (l/kg/lb): 520 / 452 / 1000 Counterweight (kg/lb): 5000 / 11030				
Description	Shoe width (mm/in)	Operating weight (kg/lb)	Ground pressure (kPa/psi)	Overall width (mm/ft-in)
Triple grouser	800 / 32	23694 / 52250	37.3 / 0.38 / 5.4	3190 / 10' 6"
	900 / 35	23988 / 52890	33.3 / 0.34 / 4.8	3290 / 10' 10"

LR : Long Reach

418 Specifications  
Dimensions

## Dimensions

Total machine, dimensions (EC220E L)

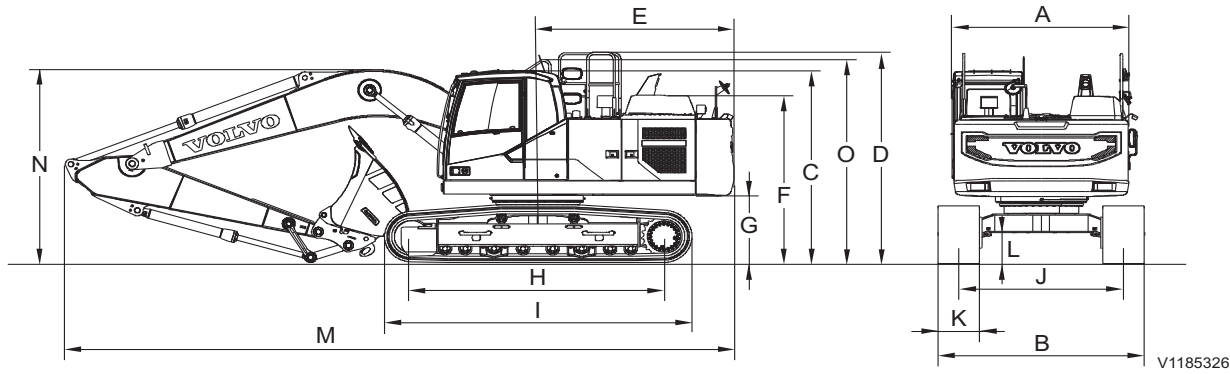

V1185326

Description	Unit	Boom			
		5.7 m (18' 8")			
		Dipper arm			
		2.0 m (6' 7")	2.5 m (8' 2")	2.9 m (9' 6")	3.5 m (11' 6")
A. Overall width of superstructure	mm ft-in	2540 8' 4"	2540 8' 4"	2540 8' 4"	2540 8' 4"
B. Overall width		2990 9' 10"	2990 9' 10"	2990 9' 10"	2990 9' 10"
C. Overall height of cab		2955 9' 8"	2955 9' 8"	2955 9' 8"	2955 9' 8"
D. Overall height of guardrail (unfolded)		3270 10' 9"	3270 10' 9"	3270 10' 9"	3270 10' 9"
D'. Overall height of guardrail (folded)		2790 9' 2"	2790 9' 2"	2790 9' 2"	2790 9' 2"
E. Tail swing radius		2850 9' 4"	2850 9' 4"	2850 9' 4"	2850 9' 4"
F. Overall height of engine hood		2600 8' 6"	2600 8' 6"	2600 8' 6"	2600 8' 6"
G. *Counterweight clearance		1025 3' 4"	1025 3' 4"	1025 3' 4"	1025 3' 4"
H. Tumbler length	3660 12' 0"	3660 12' 0"	3660 12' 0"	3660 12' 0"	



**Specifications**  
**Dimensions 419**

I. Track length	mm	4460	4460	4460	4460	
	ft-in	14' 8"	14' 8"	14' 8"	14' 8"	
J. Track gauge	mm	2390	2390	2390	2390	
	ft-in	7' 10"	7' 10"	7' 10"	7' 10"	
K. Shoe width	mm	600	600	600	600	
	in	24"	24"	24"	24"	
L. *Minimum ground clearance	mm	460	460	460	460	
		ft-in	1' 6"	1' 6"	1' 6"	1' 6"
M. Overall length		9795	9745	9690	9720	
		ft-in	32' 2"	32' 0"	31' 9"	31' 11"
M'. Overall length (Variable adjustable boom)		9660	9610	9570	9560	
		ft-in	31' 8"	31' 6"	31' 5"	31' 4"
N. Overall height of boom		3100	3080	2940	3260	
	ft-in	10' 2"	10' 1"	9' 8"	10' 8"	
N'. Overall height of boom (Variable adjustable boom)	3065	3065	2960	3310		
	ft-in	10' 1"	10' 1"	9' 9"	10' 10"	
O. Overall height of handrail	3075	3075	3075	3075		
	ft-in	10' 1"	10' 1"	10' 1"	10' 1"	

\* Without shoe grouser

**420 Specifications  
Dimensions**

**Total machine, dimensions (EC220E NL)**

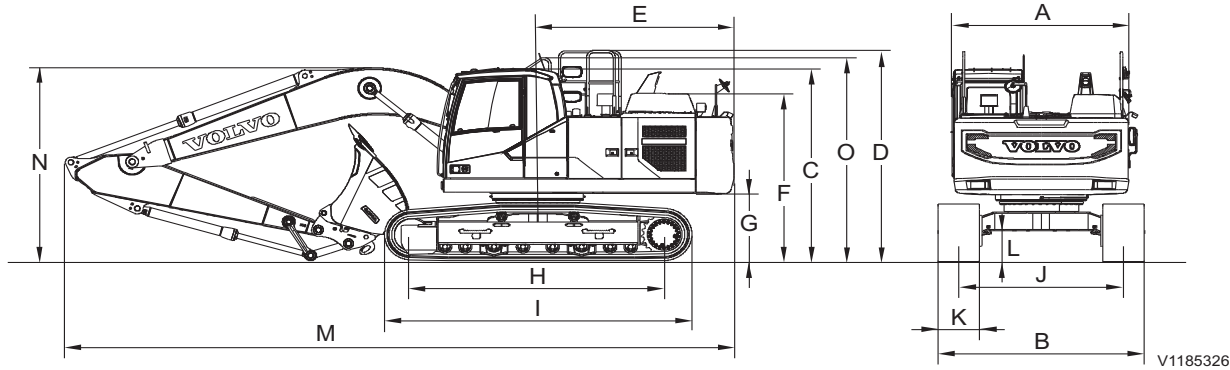

V1185326

Description	Unit	Boom			
		5.7 m (18' 8")			
		Dipper arm			
		2.0 m (6' 7")	2.5 m (8' 2")	2.9 m (9' 6")	3.5 m (11' 6")
A. Overall width of superstructure	mm ft-in	2540 8' 4"	2540 8' 4"	2540 8' 4"	2540 8' 4"
B. Overall width		2540 8' 4"	2540 8' 4"	2540 8' 4"	2540 8' 4"
C. Overall height of cab		2955 9' 8"	2955 9' 8"	2955 9' 8"	2955 9' 8"
D. Overall height of guardrail (unfolded)		3270 10' 9"	3270 10' 9"	3270 10' 9"	3270 10' 9"
D'. Overall height of guardrail (folded)		2790 9' 2"	2790 9' 2"	2790 9' 2"	2790 9' 2"
E. Tail swing radius		2850 9' 4"	2850 9' 4"	2850 9' 4"	2850 9' 4"
F. Overall height of engine hood		2600 8' 6"	2600 8' 6"	2600 8' 6"	2600 8' 6"
G. *Counterweight clearance		1025 3' 4"	1025 3' 4"	1025 3' 4"	1025 3' 4"
H. Tumbler length		3660 12' 0"	3660 12' 0"	3660 12' 0"	3660 12' 0"



**Specifications**  
**Dimensions 421**

I. Track length	mm	4460	4460	4460	4460	
	ft-in	14' 8"	14' 8"	14' 8"	14' 8"	
J. Track gauge	mm	2040	2040	2040	2040	
	ft-in	6' 8"	6' 8"	6' 8"	6' 8"	
K. Shoe width	mm	500	500	500	500	
	in	20"	20"	20"	20"	
L. *Minimum ground clearance	mm	460	460	460	460	
		ft-in	1' 6"	1' 6"	1' 6"	1' 6"
M. Overall length		9795	9745	9690	9720	
		ft-in	32' 2"	32' 0"	31' 9"	31' 11"
M'. Overall length (Variable adjustable boom)		9660	9610	9570	9560	
		ft-in	31' 8"	31' 6"	31' 5"	31' 4"
N. Overall height of boom		3100	3080	2940	3260	
	ft-in	10' 2"	10' 1"	9' 8"	10' 8"	
N'. Overall height of boom (Variable adjustable boom)	3065	3065	2960	3310		
	ft-in	10' 1"	10' 1"	9' 9"	10' 10"	
O. Overall height of handrail	3075	3075	3075	3075		
	ft-in	10' 1"	10' 1"	10' 1"	10' 1"	

\* Without shoe grouser



422 Specifications  
Dimensions

Total machine, dimensions (EC220E N)

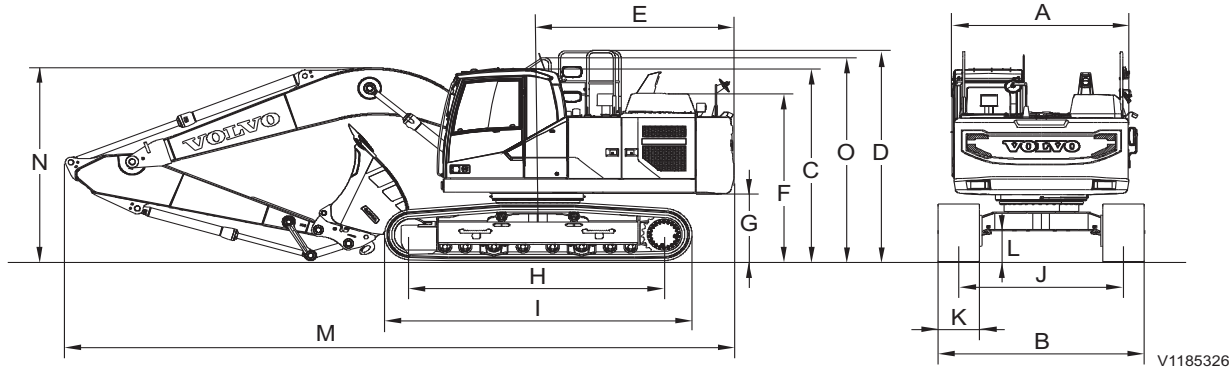

V1185326

Description	Unit	Boom			
		5.7 m (18' 8")			
		Dipper arm			
		2.0 m (6' 7")	2.5 m (8' 2")	2.9 m (9' 6")	3.5 m (11' 6")
A. Overall width of superstructure	mm ft-in	2540 8' 4"	2540 8' 4"	2540 8' 4"	2540 8' 4"
B. Overall width		2800 9' 2"	2800 9' 2"	2800 9' 2"	2800 9' 2"
C. Overall height of cab		2955 9' 8"	2955 9' 8"	2955 9' 8"	2955 9' 8"
D. Overall height of guardrail (unfolded)		3270 10' 9"	3270 10' 9"	3270 10' 9"	3270 10' 9"
D'. Overall height of guardrail (folded)		2790 9' 2"	2790 9' 2"	2790 9' 2"	2790 9' 2"
E. Tail swing radius		2850 9' 4"	2850 9' 4"	2850 9' 4"	2850 9' 4"
F. Overall height of engine hood		2600 8' 6"	2600 8' 6"	2600 8' 6"	2600 8' 6"
G. *Counterweight clearance		1025 3' 4"	1025 3' 4"	1025 3' 4"	1025 3' 4"
H. Tumbler length		3370 11' 1"	3370 11' 1"	3370 11' 1"	3370 11' 1"



**Specifications**  
**Dimensions 423**

I. Track length	mm	4160 13' 8"	4160 13' 8"	4160 13' 8"	4160 13' 8"
J. Track gauge	ft-in	2200 7' 3"	2200 7' 3"	2200 7' 3"	2200 7' 3"
K. Shoe width	mm in	600 24"	600 24"	600 24"	600 24"
L. *Minimum ground clearance	mm ft-in	460 1' 6"	460 1' 6"	460 1' 6"	460 1' 6"
M. Overall length		9795 32' 2"	9745 32' 0"	9690 31' 9"	9720 31' 11"
M'. Overall length (Variable adjustable boom)		9660 31' 8"	9610 31' 6"	9570 31' 5"	9560 31' 4"
N. Overall height of boom		3100 10' 2"	3080 10' 1"	2940 9' 8"	3260 10' 8"
N'. Overall height of boom (Variable adjustable boom)		3065 10' 1"	3065 10' 1"	2960 9' 9"	3310 10' 10"
O. Overall height of handrail		3075 10' 1"	3075 10' 1"	3075 10' 1"	3075 10' 1"

\* Without shoe grouser

**424**      **Specifications**  
**Dimensions**

**Total machine, dimensions (EC220E NH)**

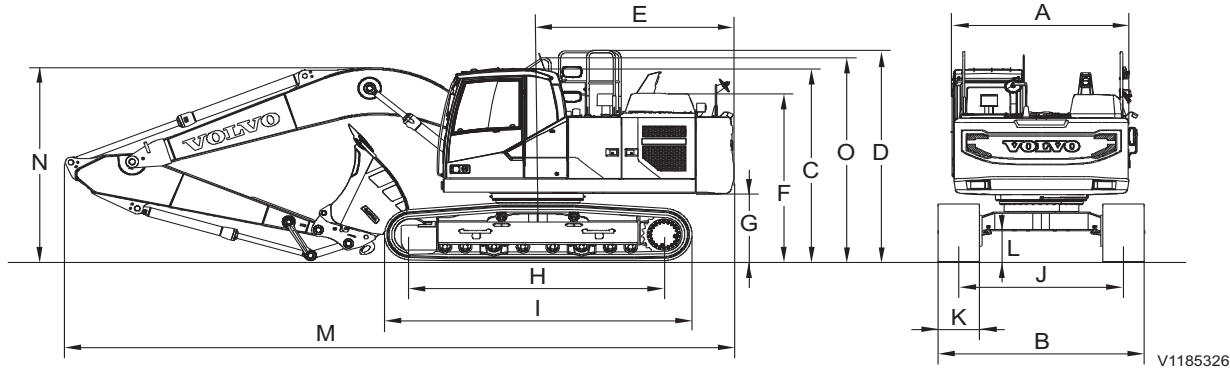

V1185326

Description	Unit	Boom			
		5.7 m (18' 8")			
		Dipper arm			
		2.0 m (6' 7")	2.5 m (8' 2")	2.9 m (9' 6")	3.5 m (11' 6")
A. Overall width of superstructure	mm ft-in	2540 8' 4"	2540 8' 4"	2540 8' 4"	2540 8' 4"
B. Overall width		2540 8' 4"	2540 8' 4"	2540 8' 4"	2540 8' 4"
C. Overall height of cab		3020 9' 11"	3020 9' 11"	3020 9' 11"	3020 9' 11"
D. Overall height of guardrail (unfolded)		3335 10' 11"	3335 10' 11"	3335 10' 11"	3335 10' 11"
D'. Overall height of guardrail (folded)		2855 9' 4"	2855 9' 4"	2855 9' 4"	2855 9' 4"
E. Tail swing radius		2850 9' 4"	2850 9' 4"	2850 9' 4"	2850 9' 4"
F. Overall height of engine hood		2665 8' 9"	2665 8' 9"	2665 8' 9"	2665 8' 9"
G. *Counterweight clearance		1090 3' 7"	1090 3' 7"	1090 3' 7"	1090 3' 7"
H. Tumbler length		3510 11' 6"	3510 11' 6"	3510 11' 6"	3510 11' 6"



**Specifications**  
**Dimensions 425**

I. Track length	mm	4360	4360	4360	4360	
	ft-in	14' 4"	14' 4"	14' 4"	14' 4"	
J. Track gauge	mm	2040	2040	2040	2040	
	ft-in	6' 8"	6' 8"	6' 8"	6' 8"	
K. Shoe width	mm	500	500	500	500	
	in	20"	20"	20"	20"	
L. *Minimum ground clearance	mm	490	490	490	490	
		ft-in	1' 7"	1' 7"	1' 7"	1' 7"
M. Overall length		9795	9745	9690	9720	
		ft-in	32' 2"	32' 0"	31' 9"	31' 11"
M'. Overall length (Variable adjustable boom)		9660	9610	9570	9560	
		ft-in	31' 8"	31' 6"	31' 5"	31' 4"
N. Overall height of boom		3100	3080	2940	3260	
		ft-in	10' 2"	10' 1"	9' 8"	10' 8"
N'. Overall height of boom (Variable adjustable boom)	3065	3065	2960	3310		
	ft-in	10' 1"	10' 1"	9' 9"	10' 10"	
O. Overall height of handrail	3140	3140	3140	3140		
	ft-in	10' 4"	10' 4"	10' 4"	10' 4"	

\* Without shoe grouser

Specifications  
426 Dimensions

Total machine, dimensions (EC220E LR)

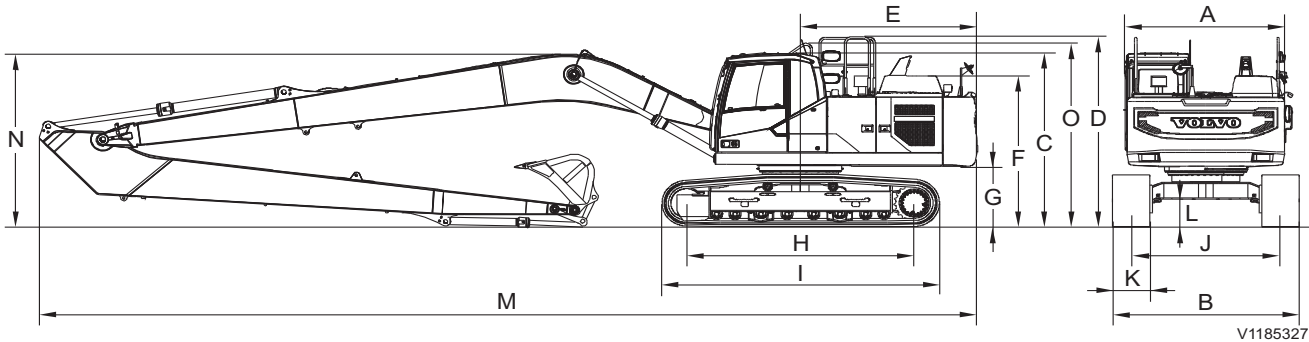

V1185327

Description	Unit	Boom
		8.85 m (29' 0")
Description	Unit	Dipper arm
		6.25 m (20' 6")
A. Overall width of superstructure	mm ft-in	2540 8' 4"
B. Overall width		3190 10' 6"
C. Overall height of cab		2955 9' 8"
D. Overall height of guardrail (unfolded)		3270 10' 9"
D'. Overall height of guardrail (folded)		2790 9' 2"
E. Tail swing radius		2850 9' 4"
F. Overall height of engine hood		2600 8' 6"
G. *Counterweight clearance		1025 3' 4"
H. Tumbler length		3660 12' 0"

**Specifications**  
**Dimensions 427**

I. Track length	mm ft-in	4460 14' 8"
J. Track gauge		2390 7' 10"
K. Shoe width	mm in	800 32"
L. *Minimum ground clearance	mm ft-in	460 1' 6"
M. Overall length		12880 42' 3"
N. Overall height of boom		3055 10' 0"
O. Overall height of handrail		3075 10' 1"

\* Without shoe grouser

Disassembled parts, dimension

Counterweight, dimension

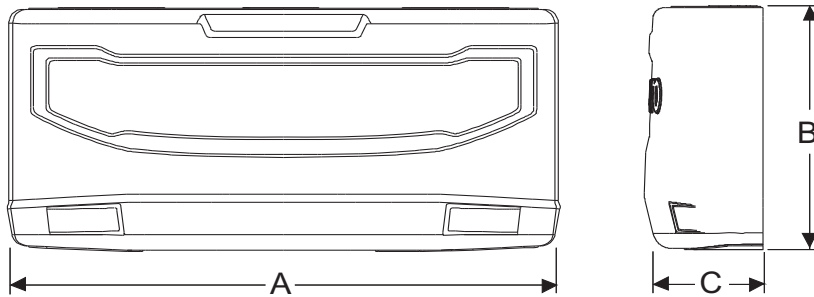

V1148986

Description	Unit	Counterweight	
		4200 kg 9260 lb	5000 kg 11030 lb
Length (A)	mm ft-in	2539 8' 4"	2539 8' 4"
Height (B)		1184 3' 11"	1184 3' 11"
Width (C)		545.2 2' 0"	545.2 2' 0"

428 Specifications  
Dimensions

Boom and dipper arm

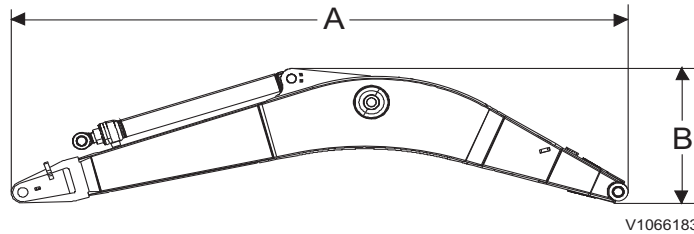

V1066183

Description	Unit	Boom			
		5.7 m (18' 8") GP	5.7 m (18' 8") HD	5.57 m (18' 3") VA	8.85 m (29' 0") LR
Length (A)	mm ft-in	5910 19' 5"	5910 19' 5"	5780 19' 0"	9060 29' 9"
Height (B)		1585 5' 2"	1585 5' 2"	1570 5' 2"	1460 4' 9"
Width		670 2' 2"	670 2' 2"	670 2' 2"	670 2' 2"

\* Includes dipper arm cylinder, piping and pin  
 GP: General Purpose  
 HD: Heavy Duty  
 VA: Variable Adjustable  
 LR: Long Reach

Specifications  
Dimensions 429

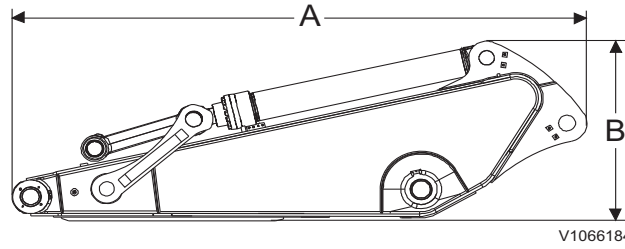

V1066184

Description	Unit	Dipper arm					
		2.0 m (6' 7") ME	2.5 m (8' 2") HD	2.9 m (9' 6") GP	2.9 m (9' 6") HD	3.5 m (11' 6") GP	6.25 m (20' 6") LR
Length (A)	mm ft-in	3065 10' 1"	3525 11' 7"	3910 12' 10"	3910 12' 10"	4540 14' 11"	7330 24' 1"
Height (B)		980 3' 3"	860 2' 10"	860 2' 10"	860 2' 10"	855 2' 10"	945 3' 1"
Width		440 1' 5"	440 1' 5"	440 1' 5"	440 1' 5"	440 1' 5"	385 1' 3"

\* Includes bucket cylinder, linkage and pin

ME: Mass Excavation

GP: General Purpose

HD: Heavy Duty

VA: Variable Adjustable

LR: Long Reach



Specifications  
430 Working ranges

## Working ranges

Mono-boom (EC220E L, EC220E NL, EC220E N, EC220E LR)

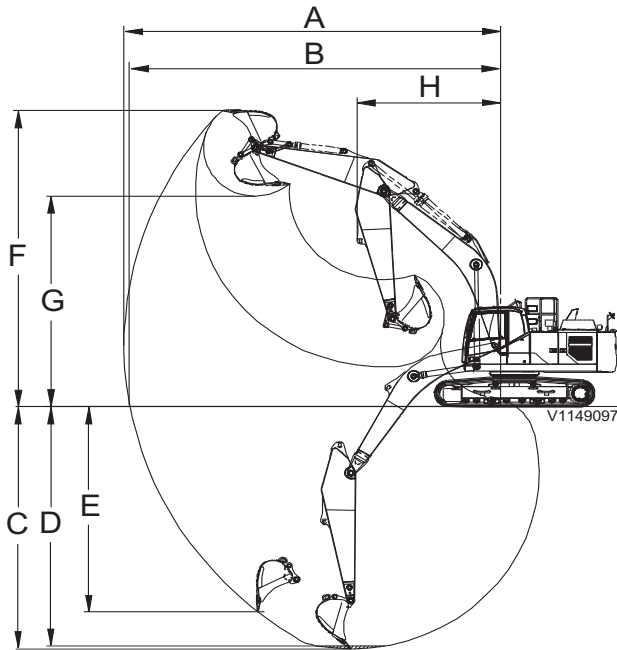

Description	Unit	Boom				
		5.7 m (18' 8")				8.85 m (29' 0")
		Dipper arm				
		2.0 m (6' 7")	2.5 m (8' 2")	2.9 m (9' 6")	3.5 m (11' 6")	6.25 m (20' 6")
A. Maximum digging reach	mm ft in	9090 29' 10"	9550 31' 4"	9930 32' 7"	10390 34' 1"	15800 51' 10"
B. Maximum digging reach on ground		8910 29' 3"	9380 30' 9"	9770 32' 1"	10240 33' 7"	15700 51' 6"
C. Maximum digging depth		5830 19' 2"	6330 20' 9"	6730 22' 1"	7330 24' 1"	12100 39' 8"
D. Maximum digging depth (level the ground of 2.44 m (8'))		5560 18' 3"	6100 20' 0"	6540 21' 5"	7130 23' 5"	12000 39' 4"
E. Maximum vertical wall digging depth		4880 16' 0"	5620 18' 5"	6090 20' 0"	6470 21' 3"	11290 37' 0"
F. Maximum cutting height		8940 29' 4"	9220 30' 3"	9460 31' 0"	9460 31' 0"	13300 43' 8"
G. Maximum dumping height		6190 20' 4"	6430 21' 1"	6650 21' 10"	6700 22' 0"	10950 35' 11"
H. Minimum front swing radius		3790 12' 5"	3670 12' 0"	3640 11' 11"	3660 12' 0"	5200 17' 1"

- Machine with direct fit bucket

**Mono-boom (EC220E NH)**

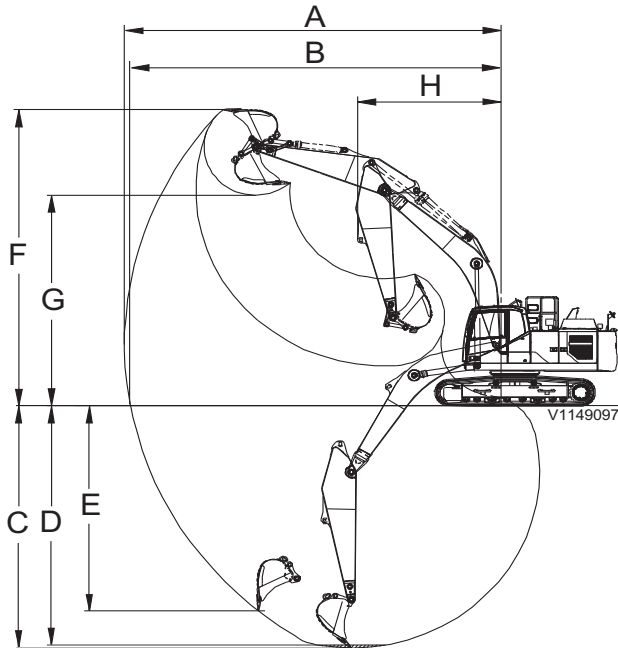

Description	Unit	Boom			
		5.7 m (18' 8")			
		Dipper arm			
		2.0 m (6' 7")	2.5 m (8' 2")	2.9 m (9' 6")	3.5 m (11' 6")
A. Maximum digging reach	mm ft in	9090 29' 10"	9550 31' 4"	9930 32' 7"	10390 34' 1"
B. Maximum digging reach on ground		8910 29' 3"	9380 30' 9"	9770 32' 1"	10240 33' 7"
C. Maximum digging depth		5760 18' 11"	6260 20' 6"	6660 21' 10"	7260 23' 10"
D. Maximum digging depth (level the ground of 2.44 m (8'))		5490 18' 0"	6030 19' 9"	6470 21' 3"	7060 23' 2"
E. Maximum vertical wall digging depth		4810 15' 9"	5550 18' 3"	6020 19' 9"	6400 21' 0"
F. Maximum cutting height		9010 29' 7"	9290 30' 6"	9530 31' 3"	9530 31' 3"
G. Maximum dumping height		6260 20' 6"	6500 21' 4"	6720 22' 1"	6770 22' 3"
H. Minimum front swing radius		3790 12' 5"	3670 12' 0"	3640 11' 11"	3660 12' 0"

- Machine with direct fit bucket

**432 Specifications**  
**Working ranges**

Variable adjustable boom (EC220E L, EC220E NL, EC220E N)

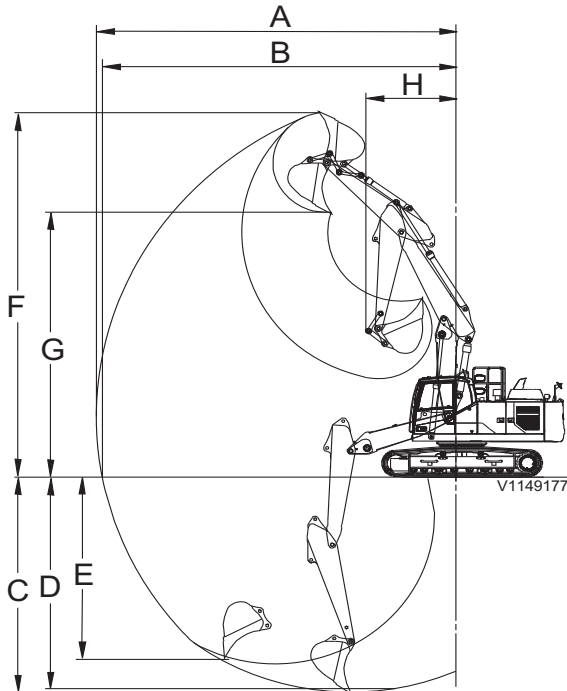

Description	Unit	Boom			
		5.57 m (18' 3")			
		Dipper arm			
		2.0 m (6' 7")	2.5 m (8' 2")	2.9 m (9' 6")	3.5 m (11' 6")
A. Maximum digging reach	mm ft in	8980 29' 6"	9450 31' 0"	9840 32' 3"	10310 33' 10"
B. Maximum digging reach on ground		8800 28' 10"	9280 30' 5"	9670 31' 9"	10150 33' 4"
C. Maximum digging depth		5410 17' 9"	5900 19' 4"	6300 20' 8"	6850 22' 6"
D. Maximum digging depth (level the ground of 2.44 m (8'))		5290 17' 4"	5790 19' 0"	6200 20' 4"	6750 22' 2"
E. Maximum vertical wall digging depth		4390 14' 5"	4990 16' 4"	5410 17' 9"	5930 19' 5"
F. Maximum cutting height		10010 32' 10"	10380 34' 1"	10710 35' 2"	10920 35' 10"
G. Maximum dumping height		7100 23' 4"	7460 24' 6"	7780 25' 6"	8010 26' 3"
H. Minimum front swing radius		2890 9' 6"	2740 9' 0"	2470 8' 1"	2730 8' 11"

- Machine with direct fit bucket

Variable adjustable boom (EC220E NH)

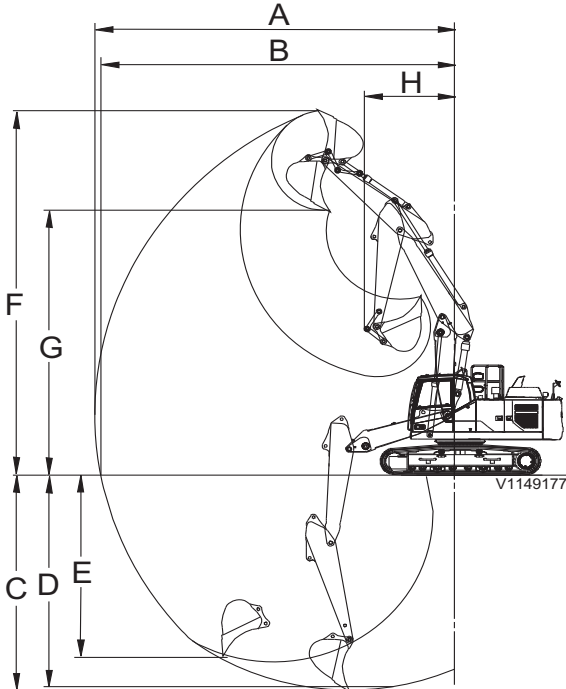

Description	Unit	Boom			
		5.57 m (18' 3")			
		Dipper arm			
		2.0 m (6' 7")	2.5 m (8' 2")	2.9 m (9' 6")	3.5 m (11' 6")
A. Maximum digging reach	mm ft in	8980 29' 6"	9450 31' 0"	9840 32' 3"	10310 33' 10"
B. Maximum digging reach on ground		8800 28' 10"	9280 30' 5"	9670 31' 9"	10150 33' 4"
C. Maximum digging depth		5340 17' 6"	5830 19' 2"	6230 20' 5"	6780 22' 3"
D. Maximum digging depth (level the ground of 2.44 m (8'))		5220 17' 2"	5720 18' 9"	6130 20' 1"	6680 21' 11"
E. Maximum vertical wall digging depth		4320 14' 2"	4920 16' 2"	5340 17' 6"	5860 19' 3"
F. Maximum cutting height		10080 33' 1"	10450 34' 3"	10780 35' 4"	10990 36' 1"
G. Maximum dumping height		7170 23' 6"	7530 24' 8"	7850 25' 9"	8080 26' 6"
H. Minimum front swing radius		2890 9' 6"	2740 9' 0"	2470 8' 1"	2730 8' 11"

- Machine with direct fit bucket

434 Specifications  
Recommended bucket sizes

**Recommended bucket sizes**

Maximum permitted buckets

EC220E L with counterweight, 4200 kg (9260 lb)

For direct-fit buckets				
Description	Unit	Boom		
		5.7 m (18' 8")		
		Dipper arm		
		2.5 m (8' 2")	2.9 m (9' 6")	3.5 m (11' 6")
GP bucket 1.5 t/m <sup>3</sup>	l / kg	1500 / 1250	1350 / 1150	1200 / 1000
GP bucket 1.8 t/m <sup>3</sup>		1325 / 1100	1200 / 1000	1075 / 900
HD bucket 1.8 t/m <sup>3</sup>		1250 / 1250	1125 / 1100	1000 / 1000
HD bucket 2.0 t/m <sup>3</sup>		1175 / 1150	1050 / 1050	950 / 950

For quick coupler buckets				
Description	Unit	Boom		
		5.7 m (18' 8")		
		Dipper arm		
		2.5 m (8' 2")	2.9 m (9' 6")	3.5 m (11' 6")
GP bucket 1.5 t/m <sup>3</sup>	l / kg	1350 / 1150	1225 / 1000	1075 / 900
GP bucket 1.8 t/m <sup>3</sup>		1200 / 1000	1075 / 900	950 / 800
HD bucket 1.8 t/m <sup>3</sup>		1150 / 1150	1025 / 1000	900 / 900
HD bucket 2.0 t/m <sup>3</sup>		1075 / 1050	950 / 950	825 / 800

**NOTE!**

Bucket size based on ISO 7451, heaped material with a 1:1 angle of repose.

**NOTE!**

"Maximum permitted sizes" are for reference only and are not necessarily available from the factory.

**NOTE!**

Bucket widths are less than bucket's tip radius.



Specifications  
**Recommended bucket sizes 435**

EC220E NC with counterweight, 4200 kg (9260 lb)

For direct-fit buckets				
Description	Unit	Boom		
		5.7 m (18' 8")		
		Dipper arm		
		2.5 m (8' 2")	2.9 m (9' 6")	3.5 m (11' 6")
GP bucket 1.5 t/m <sup>3</sup>	l / kg	1350 / 1150	1275 / 1050	1100 / 900
GP bucket 1.8 t/m <sup>3</sup>		1200 / 1000	1125 / 950	975 / 800
HD bucket 1.8 t/m <sup>3</sup>		1125 / 1100	1050 / 1050	925 / 900
HD bucket 2.0 t/m <sup>3</sup>		1050 / 1050	1000 / 1000	850 / 850

For quick coupler buckets				
Description	Unit	Boom		
		5.7 m (18' 8")		
		Dipper arm		
		2.5 m (8' 2")	2.9 m (9' 6")	3.5 m (11' 6")
GP bucket 1.5 t/m <sup>3</sup>	l / kg	1225 / 1000	1125 / 950	950 / 800
GP bucket 1.8 t/m <sup>3</sup>		1075 / 900	1000 / 850	850 / 700
HD bucket 1.8 t/m <sup>3</sup>		1025 / 1000	950 / 950	800 / 800
HD bucket 2.0 t/m <sup>3</sup>		950 / 950	875 / 850	750 / 750

**NOTE!**

Bucket size based on ISO 7451, heaped material with a 1:1 angle of repose.

**NOTE!**

"Maximum permitted sizes" are for reference only and are not necessarily available from the factory.

**NOTE!**

Bucket widths are less than bucket's tip radius.



Specifications  
436 Recommended bucket sizes

EC220E NL with counterweight, 5000 kg (11030 lb)

For direct-fit buckets				
Description	Unit	Boom		
		5.7 m (18' 8")		
		Dipper arm		
		2.5 m (8' 2")	2.9 m (9' 6")	3.5 m (11' 6")
GP bucket 1.5 t/m <sup>3</sup>	l / kg	1400 / 1150	1300 / 1100	1125 / 950
GP bucket 1.8 t/m <sup>3</sup>		1225 / 1050	1150 / 950	1000 / 850
HD bucket 1.8 t/m <sup>3</sup>		1175 / 1150	1100 / 1100	950 / 950
HD bucket 2.0 t/m <sup>3</sup>		1100 / 1100	1025 / 1000	900 / 900

For quick coupler buckets				
Description	Unit	Boom		
		5.7 m (18' 8")		
		Dipper arm		
		2.5 m (8' 2")	2.9 m (9' 6")	3.5 m (11' 6")
GP bucket 1.5 t/m <sup>3</sup>	l / kg	1250 / 1050	1175 / 1000	1000 / 850
GP bucket 1.8 t/m <sup>3</sup>		1100 / 950	1025 / 850	875 / 750
HD bucket 1.8 t/m <sup>3</sup>		1050 / 1050	975 / 950	850 / 850
HD bucket 2.0 t/m <sup>3</sup>		975 / 950	925 / 900	775 / 750

**NOTE!**

Bucket size based on ISO 7451, heaped material with a 1:1 angle of repose.

**NOTE!**

"Maximum permitted sizes" are for reference only and are not necessarily available from the factory.

**NOTE!**

Bucket widths are less than bucket's tip radius.



## Digging forces

Description		Unit	Boom				
			5.7 m (18' 8")				8.85 m (29' 0")
			Dipper arm				
			2.0 m (6' 7")	2.5 m (8' 2")	2.9 m (9' 6")	3.5 m (11' 6")	6.25 m (20' 6")
Bucket radius		mm ft-in	1528 5' 0"	1528 5' 0"	1528 5' 0"	1528 5' 0"	1250 4' 1"
Breakout force	Normal, SAE	kN	146	125	125	125	68
		kg	14883	12742	12742	12742	6932
		lb	32820	28100	28100	28100	15290
	Power boost, SAE	kN	154	132	132	132	–
		kg	15698	13456	13456	13456	–
		lb	34620	29670	29670	29670	–
	Normal, ISO	kN	165	141	141	141	77
		kg	16820	14373	14373	14373	7849
		lb	37090	31700	31700	31700	17310
	Power boost, ISO	kN	174	149	149	149	–
		kg	17737	15189	15189	15189	–
		lb	39120	33500	33500	33500	–
Tearout force	Normal, SAE	kN	144	117	101	92	44
		kg	14679	11927	10296	9378	4485
		lb	32370	26300	22710	20680	9890
	Power boost, SAE	kN	153	124	107	97	–
		kg	15596	12640	10907	9888	–
		lb	34400	27880	24050	21810	–
	Normal, ISO	kN	149	121	104	94	45
		kg	15189	12334	10601	9582	4587
		lb	33500	27200	23380	21130	10120
	Power boost, ISO	kN	158	128	110	99	–
		kg	16106	13048	11213	10092	–
		lb	35520	28780	24730	22260	–
Rotation angle, bucket		deg. (°)	166	175	175	175	178





**438**      Specifications  
**Digging forces**

Description		Unit	Variable adjustable boom			
			5.57 m (18' 3")			
			Dipper arm			
			2.0 m (6' 7")	2.5 m (8' 2")	2.9 m (9' 6")	3.5 m (11' 6")
Bucket radius		mm ft-in	1528 5' 0"	1528 5' 0"	1528 5' 0"	1528 5' 0"
Breakout force	Normal, SAE	kN	146	125	125	125
		kg lb	14883 32820	12742 28100	12742 28100	12742 28100
	Power boost, SAE	kN	154	132	132	132
		kg lb	15698 34620	13456 29670	13456 29670	13456 29670
Normal, ISO	kN	165	141	141	141	
	kg lb	16820 37090	14373 31700	14373 31700	14373 31700	
Power boost, ISO	kN	174	149	149	149	
	kg lb	17737 39120	15189 33500	15189 33500	15189 33500	
Tearout force	Normal, SAE	kN	144	117	101	92
		kg lb	14679 32370	11927 26300	10296 22710	9378 20680
	Power boost, SAE	kN	153	124	107	97
		kg lb	15596 34400	12640 27880	10907 24050	9888 21810
Normal, ISO	kN	149	121	104	94	
	kg lb	15189 33500	12334 27200	10601 23380	9582 21130	
Power boost, ISO	kN	158	128	110	99	
	kg lb	16106 35520	13048 28780	11213 24730	10092 22260	
Rotation angle, bucket		deg.(°)	166	175	175	175

## Lifting capacities

For Europe and Others

EC220E L	H	1.5 m		3.0 m		4.5 m		6.0 m		7.5 m		9.0 m		Max. Reach		
																Max.
		kg	kg	kg	kg	kg	kg	kg	kg	kg	kg	kg	kg	kg	kg	m
HD Boom: 5.7 m ME Dipper arm: 2.0 m Shoe: 600 mm Counterweight: 4200 kg	7.5 m	-	-	-	-	-	-	-	-	-	-	-	-	*6270	*6270	4.9
	6 m	-	-	-	-	-	-	*6020	5560	-	-	-	-	*6060	5110	6.3
	4.5 m	-	-	-	-	*7650	*7650	*6410	5410	-	-	-	-	*6100	4140	7.1
	3 m	-	-	-	-	*9620	7760	*7210	5160	5760	3720	-	-	5740	3700	7.5
	1.5 m	-	-	-	-	-	-	7880	4940	5660	3630	-	-	5540	3550	7.6
	0 m	-	-	-	-	*11520	7190	7730	4820	-	-	-	-	5720	3650	7.4
	-1.5 m	-	-	-	-	*11130	7220	7720	4810	-	-	-	-	6390	4050	6.9
	-3 m	-	-	*13280	*13280	*9870	7380	-	-	-	-	-	-	*7320	5100	5.9
HD Boom: 5.7 m HD Dipper arm: 2.5 m Shoe: 600 mm Counterweight: 4200 kg	7.5 m	-	-	-	-	-	-	-	-	-	-	-	-	*5640	*5640	5.6
	6 m	-	-	-	-	-	-	*5470	*5470	-	-	-	-	*5570	4530	6.9
	4.5 m	-	-	-	-	*6960	*6960	*5990	5510	*5640	3860	-	-	*5650	3780	7.6
	3 m	-	-	-	-	*8960	7980	*6860	5250	5820	3770	-	-	5270	3420	8
	1.5 m	-	-	-	-	*10700	7480	*7750	5010	5690	3660	-	-	5100	3290	8.1
	0 m	-	-	-	-	*11480	7250	7780	4850	5610	3580	-	-	5240	3360	7.9
	-1.5 m	-	-	*10840	*10840	*11390	7220	7720	4800	-	-	-	-	5750	3670	7.4
	-3 m	-	-	*14640	14310	*10480	7320	*7730	4880	-	-	-	-	*6950	4440	6.5
-4.5 m	-	-	*11290	*11290	*8060	7620	-	-	-	-	-	-	*7090	6640	5	
HD Boom: 5.7 m HD Dipper arm: 2.9 m Shoe: 600 mm Counterweight: 4200 kg	7.5 m	-	-	-	-	-	-	*5130	*5130	-	-	-	-	*4900	*4900	6.2
	6 m	-	-	-	-	-	-	*5030	*5030	-	-	-	-	*4570	4120	7.3
	4.5 m	-	-	-	-	-	-	*5600	5570	*5280	3900	-	-	*4510	3490	8
	3 m	-	-	-	-	*8350	8110	*6510	5300	*5680	3790	-	-	*4630	3180	8.4
	1.5 m	-	-	-	-	*10250	7550	*7470	5030	5700	3660	-	-	4750	3060	8.5
	0 m	-	-	*5410	*5410	*11290	7250	7770	4840	5590	3560	-	-	4860	3110	8.3
	-1.5 m	*6260	*6260	*10310	*10310	*11450	7170	7680	4760	5560	3530	-	-	5280	3370	7.8
	-3 m	*11370	*11370	*15470	14120	*10790	7230	7720	4800	-	-	-	-	6270	3970	6.9
-4.5 m	-	-	*12570	*12570	*8930	7470	-	-	-	-	-	-	*6820	5530	5.6	
HD Boom: 5.7 m GP Dipper arm: 2.9 m Shoe: 600 mm Counterweight: 4200 kg	7.5 m	-	-	-	-	-	-	*5150	*5150	-	-	-	-	*4910	*4910	6.2
	6 m	-	-	-	-	-	-	*5050	*5050	-	-	-	-	*4580	4140	7.3
	4.5 m	-	-	-	-	-	-	*5630	5590	*5310	3930	-	-	*4520	3510	8
	3 m	-	-	-	-	*8390	8140	*6550	5330	*5710	3810	-	-	*4640	3200	8.4
	1.5 m	-	-	-	-	*10300	7590	*7510	5060	5720	3690	-	-	4780	3090	8.5
	0 m	-	-	*5420	*5420	*11340	7290	7810	4880	5620	3590	-	-	4880	3140	8.3
	-1.5 m	*6270	*6270	*10320	*10320	*11500	7210	7720	4800	5580	3560	-	-	5310	3390	7.8
	-3 m	*11380	*11380	*15530	14190	*10840	7280	7760	4840	-	-	-	-	6290	4000	6.9
-4.5 m	-	-	*12620	*12620	*8970	7510	-	-	-	-	-	-	*6860	5560	5.6	

: Along undercarriage, : Across undercarriage, H : Lifting hook related to ground level

1. Machine in "Fine Mode-F" (Power Boost), for lifting capacities.
2. The above loads are in compliance with SAE and ISO Hydraulic Excavator Lift Capacity Standards.
3. Rated loads do not exceed 87% of hydraulic lifting capacity or 75% of tipping load.
4. Rated loads marked with an asterisk ( \* ) are limited by hydraulic capacity rather than tipping load.



## Specifications 440 Lifting capacities

EC220E L	H	1.5 m		3.0 m		4.5 m		6.0 m		7.5 m		9.0 m		Max. Reach		Max. m
		kg	kg	kg	kg	kg	kg	kg	kg	kg	kg	kg	kg	kg	kg	
GP Boom: 5.7 m ME Dipper arm: 2.0 m Shoe: 600 mm Counterweight: 4200 kg	7.5 m	-	-	-	-	-	-	-	-	-	-	-	-	*6300	*6300	4.9
	6 m	-	-	-	-	-	-	*6050	5570	-	-	-	-	*6100	5120	6.3
	4.5 m	-	-	-	-	*7690	*7690	*6450	5430	-	-	-	-	*6140	4170	7.1
	3 m	-	-	-	-	*9680	7800	*7260	5190	5780	3750	-	-	5760	3730	7.5
	1.5 m	-	-	-	-	-	-	7910	4980	5690	3660	-	-	5570	3590	7.6
	0 m	-	-	-	-	*11610	7260	7770	4860	-	-	-	-	5740	3680	7.4
	-1.5 m	-	-	-	-	*11220	7280	7760	4850	-	-	-	-	6420	4090	6.9
	-3 m	-	-	*13400	*13400	*9960	7430	-	-	-	-	-	-	*7380	5140	5.9
GP Boom: 5.7 m HD Dipper arm: 2.5 m Shoe: 600 mm Counterweight: 4200 kg	7.5 m	-	-	-	-	-	-	-	-	-	-	-	-	*5670	*5670	5.6
	6 m	-	-	-	-	-	-	*5500	*5500	-	-	-	-	*5600	4550	6.9
	4.5 m	-	-	-	-	*7000	*7000	*6020	5520	*5680	3890	-	-	*5690	3800	7.6
	3 m	-	-	-	-	*9020	8010	*6910	5280	5830	3800	-	-	5290	3450	8
	1.5 m	-	-	-	-	*10780	7530	*7800	5050	5720	3690	-	-	5130	3320	8.1
	0 m	-	-	-	-	*11570	7310	7810	4900	5640	3620	-	-	5260	3390	7.9
	-1.5 m	-	-	*10840	*10840	*11480	7280	7760	4850	-	-	-	-	5780	3700	7.4
	-3 m	-	-	*14760	14420	*10560	7390	*7790	4920	-	-	-	-	*7010	4470	6.5
GP Boom: 5.7 m HD Dipper arm: 2.9 m Shoe: 600 mm Counterweight: 4200 kg	-4.5 m	-	-	*11400	*11400	*8140	7670	-	-	-	-	-	-	*7150	6690	5
	7.5 m	-	-	-	-	-	-	*5150	*5150	-	-	-	-	*4900	*4900	6.2
	6 m	-	-	-	-	-	-	*5050	*5050	-	-	-	-	*4570	4130	7.3
	4.5 m	-	-	-	-	-	-	*5630	5570	*5320	3920	-	-	*4510	3510	8
	3 m	-	-	-	-	*8410	8130	*6560	5320	*5720	3810	-	-	*4630	3200	8.4
	1.5 m	-	-	-	-	*10320	7590	*7530	5060	5720	3690	-	-	4770	3090	8.5
	0 m	-	-	*5410	*5410	*11380	7310	7800	4890	5620	3590	-	-	4880	3140	8.3
	-1.5 m	*6260	*6260	*10310	*10310	*11540	7230	7720	4810	5580	3560	-	-	5300	3400	7.8
GP Boom: 5.7 m GP Dipper arm: 2.9 m Shoe: 600 mm Counterweight: 4200 kg	-3 m	*11370	*11370	*15600	14230	*10880	7300	7760	4850	-	-	-	-	6300	4010	6.9
	-4.5 m	-	-	*12680	*12680	*9000	7520	-	-	-	-	-	-	*6880	5570	5.6
	7.5 m	-	-	-	-	-	-	*5180	*5180	-	-	-	-	*4910	*4910	6.2
	6 m	-	-	-	-	-	-	*5080	*5080	-	-	-	-	*4580	4150	7.3
	4.5 m	-	-	-	-	-	-	*5660	5600	*5350	3940	-	-	*4520	3530	8
	3 m	-	-	-	-	*8440	8160	*6590	5350	*5750	3840	-	-	*4640	3230	8.4
	1.5 m	-	-	-	-	*10370	7640	*7570	5100	5740	3710	-	-	4800	3110	8.5
	0 m	-	-	*5420	*5420	*11430	7350	7840	4920	5640	3620	-	-	4910	3170	8.3
GP Boom: 5.7 m GP Dipper arm: 2.9 m Shoe: 600 mm Counterweight: 4200 kg	-1.5 m	*6270	*6270	*10320	*10320	*11590	7280	7750	4840	5610	3590	-	-	5330	3430	7.8
	-3 m	*11380	*11380	*15660	14300	*10930	7340	7790	4880	-	-	-	-	6320	4040	6.9
	-4.5 m	-	-	*12740	*12740	*9050	7560	-	-	-	-	-	-	*6920	5600	5.6

: Along undercarriage, : Across undercarriage, H : Lifting hook related to ground level

1. Machine in "Fine Mode-F" (Power Boost), for lifting capacities.
2. The above loads are in compliance with SAE and ISO Hydraulic Excavator Lift Capacity Standards.
3. Rated loads do not exceed 87% of hydraulic lifting capacity or 75% of tipping load.
4. Rated loads marked with an asterisk ( \* ) are limited by hydraulic capacity rather than tipping load.



Specifications  
**Lifting capacities 441**













EC220E L	H	1.5 m		3.0 m		4.5 m		6.0 m		7.5 m		9.0 m		Max. Reach		
																Max.
		kg	kg	kg	kg	kg	kg	kg	kg	kg	kg	kg	kg	kg	kg	m
<b>HD Boom: 5.7 m</b> <b>GP Dipper arm: 3.5 m</b> <b>Shoe: 600 mm</b> <b>Counterweight: 4200 kg</b>	7.5 m	-	-	-	-	-	-	-	-	-	-	-	-	*4870	4360	7.1
	6 m	-	-	-	-	-	-	-	-	*4580	4040	-	-	*4820	3480	8.1
	4.5 m	-	-	-	-	-	-	*4840	*4840	*4720	3960	-	-	4650	3030	8.8
	3 m	-	-	-	-	-	-	*5700	5380	*5130	3830	4390	2840	4320	2790	9.1
	1.5 m	-	-	-	-	-	-	*6670	5080	*5640	3670	4330	2780	4210	2700	9.2
	0 m	-	-	-	-	-	-	*7460	4850	5580	3540	-	-	4280	2730	9
	-1.5 m	-	-	-	-	*10670	7100	7640	4720	5500	3470	-	-	4580	2920	8.6
	-3 m	-	-	*15170	13840	*10390	7110	7630	4710	5530	3500	-	-	5260	3340	7.8
-4.5 m	*16720	*16720	*12910	*12910	*9180	7270	*6770	4840	-	-	-	-	*5780	4280	6.6	
<b>GP Boom: 5.7 m</b> <b>GP Dipper arm: 3.5 m</b> <b>Shoe: 600 mm</b> <b>Counterweight: 4200 kg</b>	7.5 m	-	-	-	-	-	-	-	-	-	-	-	-	*4900	4370	7.1
	6 m	-	-	-	-	-	-	-	-	*4610	4050	-	-	*4850	3500	8.1
	4.5 m	-	-	-	-	-	-	*4860	*4860	*4750	3980	-	-	4670	3050	8.8
	3 m	-	-	-	-	-	-	*5740	5400	*5170	3840	4410	2860	4340	2810	9.1
	1.5 m	-	-	-	-	-	-	*6720	5110	*5680	3700	4350	2800	4220	2720	9.2
	0 m	-	-	-	-	-	-	*7520	4880	5600	3570	-	-	4300	2760	9
	-1.5 m	-	-	-	-	*10750	7160	7670	4760	5530	3510	-	-	4610	2950	8.6
	-3 m	-	-	*15300	13960	*10470	7170	7660	4750	5550	3530	-	-	5280	3370	7.8
-4.5 m	*16720	*16720	*13020	*13020	*9260	7330	*6830	4880	-	-	-	-	*5830	4320	6.6	



: Along undercarriage, : Across undercarriage, H : Lifting hook related to ground level

1. Machine in "Fine Mode-F" (Power Boost), for lifting capacities.
2. The above loads are in compliance with SAE and ISO Hydraulic Excavator Lift Capacity Standards.
3. Rated loads do not exceed 87% of hydraulic lifting capacity or 75% of tipping load.
4. Rated loads marked with an asterisk ( \* ) are limited by hydraulic capacity rather than tipping load.



## Specifications 442 Lifting capacities

EC220E L	H	3.0 m		4.5 m		6.0 m		7.5 m		9.0 m		Max. Reach		
														Max.
		kg	kg	kg	kg	kg	kg	kg	kg	kg	kg	kg	kg	m
VA Boom: 5.57 m ME Dipper arm: 2.0 m Shoe: 600 mm Counterweight: 4200 kg	7.5 m	-	-	*8610	*8610	-	-	-	-	-	-	*8490	8090	4.8
	6 m	-	-	*8600	*8600	*7490	5530	-	-	-	-	*7420	5260	6.2
	4.5 m	-	-	*9600	8430	*7690	5400	-	-	-	-	6560	4220	7
	3 m	-	-	*10920	7780	*8160	5150	-	-	-	-	5870	3760	7.4
	1.5 m	-	-	-	-	7910	4920	5680	3610	-	-	5670	3600	7.5
	0 m	-	-	*10900	7160	7760	4790	-	-	-	-	5860	3700	7.3
	-1.5 m	-	-	*9390	7190	*7140	4800	-	-	-	-	*5910	4140	6.7
	-3 m	-	-	*6710	*6710	-	-	-	-	-	-	-	-	-
VA Boom: 5.57 m HD Dipper arm: 2.5 m Shoe: 600 mm Counterweight: 4200 kg	7.5 m	-	-	*7840	*7840	-	-	-	-	-	-	*6800	6530	5.5
	6 m	-	-	*8000	*8000	*7020	5660	-	-	-	-	*6230	4630	6.7
	4.5 m	*12730	*12730	*9040	8630	*7360	5500	-	-	-	-	5920	3830	7.5
	3 m	-	-	*10490	7990	*7930	5230	5820	3730	-	-	5370	3450	7.9
	1.5 m	-	-	*11420	7440	7970	4980	5690	3620	-	-	5190	3310	8
	0 m	-	-	*11250	7190	7780	4810	5610	3550	-	-	5340	3380	7.8
	-1.5 m	*11490	*11490	*10080	7160	*7590	4770	-	-	-	-	*5700	3720	7.3
	-3 m	-	-	*7830	7290	*5670	4870	-	-	-	-	*5010	4540	6.3
VA Boom: 5.57 m HD Dipper arm: 2.9 m Shoe: 600 mm Counterweight: 4200 kg	9.0 m	-	-	-	-	-	-	-	-	-	-	*6120	*6120	4
	7.5 m	-	-	*7020	*7020	*5120	*5120	-	-	-	-	*4930	*4930	6
	6 m	-	-	*7070	*7070	*6650	5740	-	-	-	-	*4550	4190	7.2
	4.5 m	*9120	*9120	*8530	*8530	*7060	5560	5970	3870	-	-	*4460	3520	7.9
	3 m	-	-	*10050	8130	*7690	5280	5840	3760	-	-	*4550	3200	8.3
	1.5 m	-	-	*11220	7520	8000	5000	5700	3620	-	-	4830	3080	8.4
	0 m	*5930	*5930	*11360	7190	7780	4800	5590	3530	-	-	4940	3130	8.2
	-1.5 m	*10840	*10840	*10480	7110	7690	4720	5570	3500	-	-	5390	3400	7.7
-3 m	*10930	*10930	*8550	7190	*6340	4780	-	-	-	-	*4950	4050	6.8	

 : Along undercarriage,  : Across undercarriage, H : Lifting hook related to ground level

1. Machine in "Fine Mode-F" (Power Boost), for lifting capacities.
2. The above loads are in compliance with SAE and ISO Hydraulic Excavator Lift Capacity Standards.
3. Rated loads do not exceed 87% of hydraulic lifting capacity or 75% of tipping load.
4. Rated loads marked with an asterisk ( \* ) are limited by hydraulic capacity rather than tipping load.



Specifications  
Lifting capacities **443**

EC220E L	H	3.0 m		4.5 m		6.0 m		7.5 m		9.0 m		Max. Reach			
															Max.
		kg	kg	kg	kg	kg	kg	kg	kg	kg	kg	kg	kg	kg	m
VA Boom: 5.57 m GP Dipper arm: 2.9 m Shoe: 600 mm Counterweight: 4200 kg	9.0 m	-	-	-	-	-	-	-	-	-	-	*6130	*6130	4	
	7.5 m	-	-	*7030	*7030	*5140	*5140	-	-	-	-	*4940	*4940	6	
	6 m	-	-	*7080	*7080	*6680	5760	-	-	-	-	*4560	4210	7.2	
	4.5 m	*9140	*9140	*8560	*8560	*7090	5590	5990	3890	-	-	*4470	3550	7.9	
	3 m	-	-	*10090	8160	*7720	5310	5870	3780	-	-	*4570	3220	8.3	
	1.5 m	-	-	*11260	7560	8030	5030	5720	3650	-	-	*4850	3100	8.4	
	0 m	*5940	*5940	*11410	7240	7810	4840	5620	3550	-	-	4970	3160	8.2	
	-1.5 m	*10850	*10850	*10530	7150	7720	4760	5600	3530	-	-	5420	3430	7.7	
-3 m	*10990	*10990	*8600	7240	*6370	4810	-	-	-	-	*4980	4080	6.8		
VA Boom: 5.57 m GP Dipper arm: 3.5 m Shoe: 600 mm Counterweight: 4200 kg	9.0 m	-	-	-	-	-	-	-	-	-	-	*7280	6870	5.4	
	7.5 m	-	-	-	-	*6160	5910	-	-	-	-	*6200	4470	7	
	6 m	-	-	-	-	*6030	5890	*5750	4010	-	-	5430	3530	8	
	4.5 m	-	-	-	-	*6380	5690	*5770	3940	-	-	4740	3050	8.6	
	3 m	-	-	-	-	*6980	5380	5900	3800	-	-	4390	2800	9	
	1.5 m	-	-	-	-	*7580	5060	5720	3640	4320	2740	4270	2710	9.1	
	0 m	-	-	-	-	7790	4810	5580	3510	-	-	4350	2750	8.9	
	-1.5 m	-	-	*10210	7040	7650	4680	5510	3440	-	-	4680	2950	8.4	
-3 m	*11850	*11850	*8830	7060	*6680	4670	*4710	3490	-	-	*4370	3400	7.7		
-4.5 m	-	-	*6230	*6230	-	-	-	-	-	-	-	-	-	6.5	

: Along undercarriage, : Across undercarriage, H : Lifting hook related to ground level

1. Machine in "Fine Mode-F" (Power Boost), for lifting capacities.
2. The above loads are in compliance with SAE and ISO Hydraulic Excavator Lift Capacity Standards.
3. Rated loads do not exceed 87% of hydraulic lifting capacity or 75% of tipping load.
4. Rated loads marked with an asterisk ( \* ) are limited by hydraulic capacity rather than tipping load.



## Specifications 444 Lifting capacities

EC220E N	H	1.5 m		3.0 m		4.5 m		6.0 m		7.5 m		9.0 m		Max. Reach		
																Max.
		kg	kg	kg	kg	kg	kg	kg	kg	kg	kg	kg	kg	kg	kg	m
HD Boom: 5.7 m ME Dipper arm: 2.0 m Shoe: 600 mm Counterweight: 4200 kg	7.5 m	-	-	-	-	-	-	-	-	-	-	-	-	*6270	*6270	4.9
	6 m	-	-	-	-	-	-	*6020	5010	-	-	-	-	*6060	4600	6.3
	4.5 m	-	-	-	-	*7650	7500	*6410	4860	-	-	-	-	5620	3720	7.1
	3 m	-	-	-	-	*9620	6900	7110	4620	5070	3330	-	-	5050	3320	7.5
	1.5 m	-	-	-	-	-	-	6870	4400	4970	3240	-	-	4870	3170	7.6
	0 m	-	-	-	-	10470	6350	6730	4280	-	-	-	-	5010	3250	7.4
	-1.5 m	-	-	-	-	10500	6370	6720	4270	-	-	-	-	5590	3610	6.9
	-3 m	-	-	*13280	12530	*9870	6530	-	-	-	-	-	-	7100	4540	5.9
HD Boom: 5.7 m HD Dipper arm: 2.5 m Shoe: 600 mm Counterweight: 4200 kg	7.5 m	-	-	-	-	-	-	-	-	-	-	-	-	*5640	*5640	5.6
	6 m	-	-	-	-	-	-	*5470	5120	-	-	-	-	*5570	4090	6.9
	4.5 m	-	-	-	-	*6960	*6960	*5990	4960	5220	3470	-	-	5110	3400	7.6
	3 m	-	-	-	-	*8960	7110	*6860	4710	5120	3380	-	-	4640	3060	8
	1.5 m	-	-	-	-	*10700	6620	6950	4470	5000	3270	-	-	4490	2940	8.1
	0 m	-	-	-	-	10540	6400	6780	4320	4920	3190	-	-	4600	2990	7.9
	-1.5 m	-	-	*10840	*10840	10500	6370	6720	4270	-	-	-	-	5050	3270	7.4
	-3 m	-	-	*14640	12390	*10480	6480	6800	4340	-	-	-	-	6140	3960	6.5
HD Boom: 5.7 m HD Dipper arm: 2.9 m Shoe: 600 mm Counterweight: 4200 kg	-4.5 m	-	-	*11290	*11290	*8060	6770	-	-	-	-	-	-	*7090	5910	5
	7.5 m	-	-	-	-	-	-	*5130	*5130	-	-	-	-	*4900	*4900	6.2
	6 m	-	-	-	-	-	-	*5030	*5030	-	-	-	-	*4570	3710	7.3
	4.5 m	-	-	-	-	-	-	*5600	5020	5270	3510	-	-	*4510	3130	8
	3 m	-	-	-	-	*8350	7230	*6510	4750	5140	3400	-	-	4320	2840	8.4
	1.5 m	-	-	-	-	*10250	6690	6970	4490	5000	3270	-	-	4180	2730	8.5
	0 m	-	-	*5410	*5410	10540	6400	6770	4310	4900	3170	-	-	4270	2770	8.3
	-1.5 m	*6260	*6260	*10310	*10310	10450	6320	6680	4230	4870	3140	-	-	4630	3000	7.8
HD Boom: 5.7 m GP Dipper arm: 2.9 m Shoe: 600 mm Counterweight: 4200 kg	-3 m	*11370	*11370	*15470	12210	10530	6390	6720	4270	-	-	-	-	5490	3540	6.9
	-4.5 m	-	-	*12570	*12570	*8930	6620	-	-	-	-	-	-	*6820	4930	5.6
	7.5 m	-	-	-	-	-	-	*5150	*5150	-	-	-	-	*4910	*4910	6.2
	6 m	-	-	-	-	-	-	*5050	*5050	-	-	-	-	*4580	4040	7.3
	4.5 m	-	-	-	-	-	-	*5630	5470	5290	3830	-	-	*4520	3430	8
	3 m	-	-	-	-	*8390	7960	*6550	5200	5170	3720	-	-	4340	3120	8.4
	1.5 m	-	-	-	-	*10300	7410	7010	4940	5030	3590	-	-	4200	3010	8.5
	0 m	-	-	*5420	*5420	10590	7110	6800	4760	4930	3500	-	-	4290	3060	8.3
-1.5 m	*6270	*6270	*10320	*10320	10500	7030	6720	4680	4900	3470	-	-	4660	3300	7.8	
-3 m	*11380	*11380	*15530	13850	10570	7100	6760	4710	-	-	-	-	5510	3900	6.9	
-4.5 m	-	-	*12620	*12620	*8970	7330	-	-	-	-	-	-	*6860	5430	5.6	

: Along undercarriage, : Across undercarriage, H : Lifting hook related to ground level

1. Machine in "Fine Mode-F" (Power Boost), for lifting capacities.
2. The above loads are in compliance with SAE and ISO Hydraulic Excavator Lift Capacity Standards.
3. Rated loads do not exceed 87% of hydraulic lifting capacity or 75% of tipping load.
4. Rated loads marked with an asterisk ( \* ) are limited by hydraulic capacity rather than tipping load.





**Specifications**  
**Lifting capacities**      **445**

EC220E N	H	1.5 m		3.0 m		4.5 m		6.0 m		7.5 m		9.0 m		Max. Reach		
																Max.
		kg	kg	kg	kg	kg	kg	kg	kg	kg	kg	kg	kg	kg	kg	m
GP Boom: 5.7 m ME Dipper arm: 2.0 m Shoe: 600 mm Counterweight: 4200 kg	7.5 m	-	-	-	-	-	-	-	-	-	-	-	-	*6300	*6300	4.9
	6 m	-	-	-	-	-	-	*6050	5230	-	-	-	-	*6100	4810	6.3
	4.5 m	-	-	-	-	*7690	*7690	*6450	5090	-	-	-	-	5640	3910	7.1
	3 m	-	-	-	-	*9680	7280	7130	4860	5090	3500	-	-	5070	3490	7.5
	1.5 m	-	-	-	-	-	-	6900	4650	5000	3420	-	-	4890	3350	7.6
	0 m	-	-	-	-	10530	6740	6770	4530	-	-	-	-	5040	3440	7.4
	-1.5 m	-	-	-	-	10560	6770	6760	4520	-	-	-	-	5630	3820	6.9
	-3 m	-	-	*13400	*13400	*9960	6920	-	-	-	-	-	-	7140	4800	5.9
GP Boom: 5.7 m HD Dipper arm: 2.5 m Shoe: 600 mm Counterweight: 4200 kg	7.5 m	-	-	-	-	-	-	-	-	-	-	-	-	*5670	*5670	5.6
	6 m	-	-	-	-	-	-	*5500	5130	-	-	-	-	*5600	4100	6.9
	4.5 m	-	-	-	-	*7000	*7000	*6020	4980	5240	3490	-	-	5130	3420	7.6
	3 m	-	-	-	-	*9020	7150	*6910	4740	5140	3410	-	-	4670	3090	8
	1.5 m	-	-	-	-	*10780	6680	6980	4510	5030	3300	-	-	4510	2970	8.1
	0 m	-	-	-	-	10590	6470	6810	4360	4950	3230	-	-	4630	3030	7.9
	-1.5 m	-	-	*10840	*10840	10560	6440	6760	4320	-	-	-	-	5080	3310	7.4
	-3 m	-	-	*14760	12500	*10560	6540	6840	4390	-	-	-	-	6170	4000	6.5
GP Boom: 5.7 m HD Dipper arm: 2.9 m Shoe: 600 mm Counterweight: 4200 kg	-4.5 m	-	-	*11400	*11400	*8140	6820	-	-	-	-	-	-	*7150	5960	5
	7.5 m	-	-	-	-	-	-	*5150	*5150	-	-	-	-	*4900	*4900	6.2
	6 m	-	-	-	-	-	-	*5050	*5050	-	-	-	-	*4570	3720	7.3
	4.5 m	-	-	-	-	-	-	*5630	5030	5280	3530	-	-	*4510	3150	8
	3 m	-	-	-	-	*8410	7260	*6560	4780	5160	3420	-	-	4340	2870	8.4
	1.5 m	-	-	-	-	*10320	6740	7000	4530	5030	3300	-	-	4200	2760	8.5
	0 m	-	-	*5410	*5410	10600	6460	6800	4350	4930	3210	-	-	4290	2800	8.3
	-1.5 m	*6260	*6260	*10310	*10310	10510	6390	6720	4280	4900	3180	-	-	4660	3030	7.8
GP Boom: 5.7 m GP Dipper arm: 2.9 m Shoe: 600 mm Counterweight: 4200 kg	-3 m	*11370	*11370	*15600	12330	10590	6450	6760	4310	-	-	-	-	5520	3580	6.9
	-4.5 m	-	-	*12680	*12680	*9000	6670	-	-	-	-	-	-	*6880	4970	5.6
	7.5 m	-	-	-	-	-	-	*5180	*5180	-	-	-	-	*4910	*4910	6.2
	6 m	-	-	-	-	-	-	*5080	*5080	-	-	-	-	*4580	3750	7.3
	4.5 m	-	-	-	-	-	-	*5660	5050	5300	3550	-	-	*4520	3180	8
	3 m	-	-	-	-	*8440	7290	*6590	4800	5180	3440	-	-	4360	2890	8.4
	1.5 m	-	-	-	-	*10370	6780	7030	4560	5050	3320	-	-	4230	2780	8.5
	0 m	-	-	*5420	*5420	10640	6510	6840	4390	4960	3230	-	-	4320	2830	8.3
GP Boom: 5.7 m GP Dipper arm: 2.9 m Shoe: 600 mm Counterweight: 4200 kg	-1.5 m	*6270	*6270	*10320	*10320	10560	6430	6760	4310	4920	3210	-	-	4680	3060	7.8
	-3 m	*11380	*11380	*15660	12390	10630	6500	6800	4350	-	-	-	-	5540	3600	6.9
	-4.5 m	-	-	*12740	*12740	*9050	6710	-	-	-	-	-	-	*6920	5000	5.6

: Along undercarriage, : Across undercarriage, H : Lifting hook related to ground level

1. Machine in "Fine Mode-F" (Power Boost), for lifting capacities.
2. The above loads are in compliance with SAE and ISO Hydraulic Excavator Lift Capacity Standards.
3. Rated loads do not exceed 87% of hydraulic lifting capacity or 75% of tipping load.
4. Rated loads marked with an asterisk ( \* ) are limited by hydraulic capacity rather than tipping load.



## Specifications 446 Lifting capacities

EC220E N	H	1.5 m		3.0 m		4.5 m		6.0 m		7.5 m		9.0 m		Max. Reach		
																Max.
		kg	kg	kg	kg	kg	kg	kg	kg	kg	kg	kg	kg	kg	kg	m
<b>HD Boom: 5.7 m</b> <b>GP Dipper arm: 3.5 m</b> <b>Shoe: 600 mm</b> <b>Counterweight: 4200 kg</b>	7.5 m	-	-	-	-	-	-	-	-	-	-	-	-	*4910	3970	7.1
	6 m	-	-	-	-	-	-	-	-	*4620	3670	-	-	4730	3170	8.1
	4.5 m	-	-	-	-	-	-	*4880	*4880	*4770	3610	-	-	4140	2750	8.8
	3 m	-	-	-	-	-	-	*5750	4880	*5180	3470	3910	2570	3840	2530	9.1
	1.5 m	-	-	-	-	-	-	*6730	4590	5070	3320	3840	2510	3740	2440	9.2
	0 m	-	-	-	-	-	-	6830	4370	4930	3200	-	-	3800	2470	9
	-1.5 m	-	-	-	-	10460	6330	6700	4240	4860	3130	-	-	4060	2640	8.6
	-3 m	-	-	*15280	12060	*10470	6340	6680	4230	4880	3160	-	-	4650	3020	7.8
	-4.5 m	*16740	*16740	*13000	12380	*9250	6490	6820	4350	-	-	-	-	*5840	3860	6.6
<b>GP Boom: 5.7 m</b> <b>GP Dipper arm: 3.5 m</b> <b>Shoe: 600 mm</b> <b>Counterweight: 4200 kg</b>	7.5 m	-	-	-	-	-	-	-	-	-	-	-	-	*4940	3980	7.1
	6 m	-	-	-	-	-	-	-	-	*4650	3690	-	-	4740	3180	8.1
	4.5 m	-	-	-	-	-	-	*4910	*4910	*4800	3620	-	-	4160	2770	8.8
	3 m	-	-	-	-	-	-	*5790	4900	*5220	3490	3930	2600	3860	2550	9.1
	1.5 m	-	-	-	-	-	-	*6770	4620	5090	3350	3860	2540	3760	2470	9.2
	0 m	-	-	-	-	-	-	6870	4410	4960	3230	-	-	3820	2500	9
	-1.5 m	-	-	-	-	10520	6400	6740	4290	4890	3170	-	-	4090	2670	8.6
	-3 m	-	-	*15400	12180	10530	6410	6720	4280	4910	3190	-	-	4680	3050	7.8
	-4.5 m	*16740	*16740	*13110	12480	*9330	6550	6860	4400	-	-	-	-	*5890	3900	6.6

: Along undercarriage, : Across undercarriage, H : Lifting hook related to ground level

1. Machine in "Fine Mode-F" (Power Boost), for lifting capacities.
2. The above loads are in compliance with SAE and ISO Hydraulic Excavator Lift Capacity Standards.
3. Rated loads do not exceed 87% of hydraulic lifting capacity or 75% of tipping load.
4. Rated loads marked with an asterisk ( \* ) are limited by hydraulic capacity rather than tipping load.



**Specifications**  
**Lifting capacities**      **447**

EC220E N	H	3.0 m		4.5 m		6.0 m		7.5 m		9.0 m		Max. Reach		
														Max.
		kg	kg	kg	kg	kg	kg	kg	kg	kg	kg	kg	kg	m
VA Boom: 5.57 m ME Dipper arm: 2.0 m Shoe: 600 mm Counterweight: 4200 kg	7.5 m	-	-	*8600	8040	-	-	-	-	-	-	*8480	7260	4.8
	6 m	-	-	*8580	7980	*7470	4960	-	-	-	-	7160	4710	6.2
	4.5 m	-	-	*9580	7520	7400	4830	-	-	-	-	5750	3770	7
	3 m	-	-	*10890	6890	7120	4590	-	-	-	-	5140	3340	7.4
	1.5 m	-	-	-	-	6870	4360	4960	3200	-	-	4950	3190	7.5
	0 m	-	-	10460	6280	6730	4230	-	-	-	-	5110	3280	7.3
	-1.5 m	-	-	*9360	6310	6730	4230	-	-	-	-	5740	3660	6.7
	-3 m	-	-	*6690	6500	-	-	-	-	-	-	-	-	-
VA Boom: 5.57 m HD Dipper arm: 2.5 m Shoe: 600 mm Counterweight: 4200 kg	7.5 m	-	-	*7840	*7840	-	-	-	-	-	-	*6800	-	-
	6 m	-	-	*8000	*8000	*7020	5100	-	-	-	-	*6230	4160	6.7
	4.5 m	*12730	*12730	*9040	7740	*7360	4940	-	-	-	-	5210	3430	7.5
	3 m	-	-	*10490	7110	7230	4680	5110	3340	-	-	4720	3080	7.9
	1.5 m	-	-	10820	6580	6950	4430	4990	3230	-	-	4560	2950	8
	0 m	-	-	10530	6330	6770	4270	4910	3150	-	-	4670	3010	7.8
	-1.5 m	*11490	*11490	*10080	6310	6720	4220	-	-	-	-	5150	3300	7.3
	-3 m	-	-	*7830	6430	*5670	4330	-	-	-	-	*5010	4040	6.3
VA Boom: 5.57 m HD Dipper arm: 2.9 m Shoe: 600 mm Counterweight: 4200 kg	9.0 m	-	-	-	-	-	-	-	-	-	-	*6120	*6120	4
	7.5 m	-	-	*7020	*7020	*5120	*5120	-	-	-	-	*4930	*4930	6
	6 m	-	-	*7070	*7070	*6650	5180	-	-	-	-	*4550	3760	7.2
	4.5 m	*9120	*9120	*8530	7880	*7060	5010	5260	3470	-	-	*4460	3150	7.9
	3 m	-	-	*10050	7240	7290	4730	5140	3360	-	-	4380	2850	8.3
	1.5 m	-	-	10910	6660	6980	4450	5000	3230	-	-	4240	2730	8.4
	0 m	*5930	*5930	10540	6330	6760	4260	4890	3130	-	-	4330	2780	8.2
	-1.5 m	*10840	*10840	10440	6250	6680	4180	4870	3110	-	-	4720	3020	7.7
-3 m	*10930	*10930	*8550	6340	*6340	4240	-	-	-	-	*4950	3600	6.8	

: Along undercarriage, : Across undercarriage, H : Lifting hook related to ground level

1. Machine in "Fine Mode-F" (Power Boost), for lifting capacities.
2. The above loads are in compliance with SAE and ISO Hydraulic Excavator Lift Capacity Standards.
3. Rated loads do not exceed 87% of hydraulic lifting capacity or 75% of tipping load.
4. Rated loads marked with an asterisk ( \* ) are limited by hydraulic capacity rather than tipping load.



## Specifications 448 Lifting capacities

EC220E N	H	3.0 m		4.5 m		6.0 m		7.5 m		9.0 m		Max. Reach		
														Max.
		kg	kg	kg	kg	kg	kg	kg	kg	kg	kg	kg	kg	m
<b>VA Boom: 5.57 m</b> <b>GP Dipper arm: 2.9 m</b> <b>Shoe: 600 mm</b> <b>Counterweight: 4200 kg</b>	9.0 m	-	-	-	-	-	-	-	-	-	-	*6130	*6130	4
	7.5 m	-	-	*7030	*7030	*5140	*5140	-	-	-	-	*4940	*4940	6
	6 m	-	-	*7080	*7080	*6680	5200	-	-	-	-	*4560	3780	7.2
	4.5 m	*9140	*9140	*8560	7900	*7090	5030	5280	3490	-	-	*4470	3180	7.9
	3 m	-	-	*10090	7270	7310	4760	5160	3380	-	-	4400	2870	8.3
	1.5 m	-	-	10960	6700	7010	4490	5020	3250	-	-	4260	2760	8.4
	0 m	*5940	*5940	10580	6380	6800	4290	4920	3160	-	-	4360	2810	8.2
	-1.5 m	*10850	*10850	10490	6300	6710	4220	4900	3140	-	-	4740	3050	7.7
	-3 m	*10990	*10990	*8600	6380	*6370	4270	-	-	-	-	*4980	3630	6.8
<b>VA Boom: 5.57 m</b> <b>GP Dipper arm: 3.5 m</b> <b>Shoe: 600 mm</b> <b>Counterweight: 4200 kg</b>	9.0 m	-	-	-	-	-	-	-	-	-	-	*7330	6230	5.4
	7.5 m	-	-	-	-	*6200	5380	-	-	-	-	6080	4060	7
	6 m	-	-	-	-	*6070	5350	5450	3640	-	-	4830	3200	8
	4.5 m	-	-	-	-	*6420	5160	5380	3580	-	-	4210	2760	8.6
	3 m	-	-	-	-	*7030	4870	5230	3440	-	-	3900	2530	9
	1.5 m	-	-	-	-	7100	4560	5060	3290	3830	2470	3780	2440	9.1
	0 m	-	-	-	-	6830	4320	4920	3160	-	-	3850	2480	8.9
	-1.5 m	-	-	*10290	6260	6690	4190	4850	3100	-	-	4130	2650	8.4
	-3 m	*11950	*11950	*8910	6280	6690	4190	*4760	3140	-	-	*4420	3060	7.7
-4.5 m	-	-	*6300	*6300	-	-	-	-	-	-	-	-	6.5	

: Along undercarriage, : Across undercarriage, H : Lifting hook related to ground level

1. Machine in "Fine Mode-F" (Power Boost), for lifting capacities.
2. The above loads are in compliance with SAE and ISO Hydraulic Excavator Lift Capacity Standards.
3. Rated loads do not exceed 87% of hydraulic lifting capacity or 75% of tipping load.
4. Rated loads marked with an asterisk ( \* ) are limited by hydraulic capacity rather than tipping load.



**Specifications**  
**Lifting capacities**      **449**

EC220E NL	H	1.5 m		3.0 m		4.5 m		6.0 m		7.5 m		9.0 m		Max. Reach		
																Max.
		kg	kg	kg	kg	kg	kg	kg	kg	kg	kg	kg	kg	kg	kg	m
HD Boom: 5.7 m ME Dipper arm: 2.0 m Shoe: 500 mm Counterweight: 5000 kg	7.5 m	-	-	-	-	-	-	-	-	-	-	-	-	*6270	*6270	4.9
	6 m	-	-	-	-	-	-	*6020	5140	-	-	-	-	*6060	4730	6.3
	4.5 m	-	-	-	-	*7650	7640	*6410	5000	-	-	-	-	*6100	3850	7.1
	3 m	-	-	-	-	*9620	7050	*7210	4760	6130	3450	-	-	6110	3440	7.5
	1.5 m	-	-	-	-	-	-	*7980	4550	6030	3360	-	-	5900	3300	7.6
	0 m	-	-	-	-	*11520	6510	8240	4430	-	-	-	-	6100	3380	7.3
	-1.5 m	-	-	-	-	*11130	6530	8230	4420	-	-	-	-	6810	3740	6.8
	-3 m	-	-	*13280	12560	*9870	6690	-	-	-	-	-	-	*7320	4690	5.8
HD Boom: 5.7 m HD Dipper arm: 2.5 m Shoe: 500 mm Counterweight: 5000 kg	7.5 m	-	-	-	-	-	-	-	-	-	-	-	-	*5640	*5640	5.6
	6 m	-	-	-	-	-	-	*5470	5260	-	-	-	-	*5570	4210	6.8
	4.5 m	-	-	-	-	*6960	*6960	*5990	5100	*5640	3590	-	-	*5650	3520	7.5
	3 m	-	-	-	-	*8960	7260	*6860	4850	*5950	3500	-	-	5610	3180	7.9
	1.5 m	-	-	-	-	*10700	6780	*7750	4620	6070	3400	-	-	5440	3060	8.0
	0 m	-	-	-	-	*11480	6560	8280	4460	5980	3320	-	-	5590	3110	7.8
	-1.5 m	-	-	*10840	*10840	*11390	6530	8230	4420	-	-	-	-	6140	3400	7.3
	-3 m	-	-	*14640	12430	*10480	6640	*7730	4490	-	-	-	-	*6950	4100	6.4
HD Boom: 5.7 m GP Dipper arm: 2.9 m Shoe: 500 mm Counterweight: 5000 kg	-4.5 m	-	-	*11290	*11290	*8060	6920	-	-	-	-	-	-	*7090	6070	4.9
	7.5 m	-	-	-	-	-	-	*5150	*5150	-	-	-	-	*4910	*4910	6.1
	6 m	-	-	-	-	-	-	*5050	*5050	-	-	-	-	*4580	3850	7.3
	4.5 m	-	-	-	-	-	-	*5630	5170	*5310	3650	-	-	*4520	3270	8.0
	3 m	-	-	-	-	*8390	7410	*6550	4920	*5710	3540	-	-	*4640	2980	8.3
	1.5 m	-	-	-	-	*10300	6890	*7510	4670	6100	3420	-	-	*4950	2870	8.4
	0 m	-	-	*5420	*5420	*11340	6610	*8210	4490	5990	3330	-	-	5210	2910	8.2
	-1.5 m	*6270	*6270	*10320	*10320	*11500	6530	8220	4410	5960	3300	-	-	5660	3150	7.7
HD Boom: 5.7 m HD Dipper arm: 2.9 m Shoe: 500 mm Counterweight: 5000 kg	-3 m	*11380	*11380	*15530	12320	*10840	6590	*8020	4450	-	-	-	-	*6600	3700	6.9
	-4.5 m	-	-	*12620	*12620	*8970	6810	-	-	-	-	-	-	*6860	5110	5.5
	7.5 m	-	-	-	-	-	-	*5130	*5130	-	-	-	-	*4900	*4900	6.1
	6 m	-	-	-	-	-	-	*5030	*5030	-	-	-	-	*4570	3830	7.3
	4.5 m	-	-	-	-	-	-	*5600	5150	*5280	3630	-	-	*4510	3250	8.0
	3 m	-	-	-	-	*8350	7380	*6510	4890	*5680	3520	-	-	*4630	2960	8.3
	1.5 m	-	-	-	-	*10250	6850	*7470	4640	6070	3390	-	-	*4940	2840	8.4
	0 m	-	-	*5410	*5410	*11290	6560	*8170	4450	5960	3300	-	-	5190	2890	8.2
HD Boom: 5.7 m HD Dipper arm: 2.9 m Shoe: 500 mm Counterweight: 5000 kg	-1.5 m	*6260	*6260	*10310	*10310	*11450	6480	8190	4380	5930	3270	-	-	5630	3120	7.7
	-3 m	*11370	*11370	*15470	12260	*10790	6550	*7980	4410	-	-	-	-	*6570	3670	6.9
	-4.5 m	-	-	*12570	*12570	*8930	6770	-	-	-	-	-	-	*6820	5080	5.5

: Along undercarriage, : Across undercarriage, H : Lifting hook related to ground level

1. Machine in "Fine Mode-F" (Power Boost), for lifting capacities.
2. The above loads are in compliance with SAE and ISO Hydraulic Excavator Lift Capacity Standards.
3. Rated loads do not exceed 87% of hydraulic lifting capacity or 75% of tipping load.
4. Rated loads marked with an asterisk ( \* ) are limited by hydraulic capacity rather than tipping load.



## Specifications 450 Lifting capacities

EC220E NL	H	1.5 m		3.0 m		4.5 m		6.0 m		7.5 m		9.0 m		Max. Reach		Max. m		
																	kg	kg
		kg	kg	kg	kg	kg	kg	kg	kg	kg	kg	kg	kg	kg				
GP Boom: 5.7 m ME Dipper arm: 2.0 m Shoe: 500 mm Counterweight: 5000 kg	7.5 m	-	-	-	-	-	-	-	-	-	-	-	-	*6300	*6300	4.9		
	6 m	-	-	-	-	-	-	*6050	5160	-	-	-	-	*6100	4750	6.3		
	4.5 m	-	-	-	-	*7690	7660	*6450	5020	-	-	-	-	*6140	3870	7.1		
	3 m	-	-	-	-	*9680	7090	*7260	4790	6150	3480	-	-	6130	3470	7.5		
	1.5 m	-	-	-	-	-	-	*8040	4590	6060	3400	-	-	5930	3330	7.6		
	0 m	-	-	-	-	*11610	6580	8280	4470	-	-	-	-	6120	3410	7.3		
	-1.5 m	-	-	-	-	*11220	6600	8270	4470	-	-	-	-	6840	3780	6.8		
	-3 m	-	-	*13400	12660	*9960	6750	-	-	-	-	-	-	*7380	4730	5.8		
GP Boom: 5.7 m HD Dipper arm: 2.5 m Shoe: 500 mm Counterweight: 5000 kg	7.5 m	-	-	-	-	-	-	-	-	-	-	-	-	*5670	*5670	5.6		
	6 m	-	-	-	-	-	-	*5500	5270	-	-	-	-	*5600	4230	6.8		
	4.5 m	-	-	-	-	*7000	*7000	*6020	5110	*5680	3620	-	-	*5690	3540	7.5		
	3 m	-	-	-	-	*9020	7290	*6910	4880	*5990	3530	-	-	5630	3210	7.9		
	1.5 m	-	-	-	-	*10780	6840	*7800	4660	6090	3430	-	-	5460	3090	8.0		
	0 m	-	-	-	-	*11570	6630	8320	4510	6010	3360	-	-	5610	3150	7.8		
	-1.5 m	-	-	*10840	*10840	*11480	6600	8260	4460	-	-	-	-	6160	3440	7.3		
	-3 m	-	-	*14760	12540	*10560	6700	*7790	4540	-	-	-	-	*7010	4140	6.4		
-4.5 m	-	-	*11400	*11400	*8140	6970	-	-	-	-	-	-	*7150	6110	4.9			
GP Boom: 5.7 m GP Dipper arm: 2.9 m Shoe: 500 mm Counterweight: 5000 kg	7.5 m	-	-	-	-	-	-	*5180	*5180	-	-	-	-	*4910	*4910	6.1		
	6 m	-	-	-	-	-	-	*5080	*5080	-	-	-	-	*4580	3870	7.3		
	4.5 m	-	-	-	-	-	-	*5660	5190	*5350	3670	-	-	*4520	3300	8.0		
	3 m	-	-	-	-	*8440	7440	*6590	4940	*5750	3570	-	-	*4640	3010	8.3		
	1.5 m	-	-	-	-	*10370	6940	*7570	4700	6120	3450	-	-	*4950	2900	8.4		
	0 m	-	-	*5420	*5420	*11430	6670	*8270	4530	6010	3360	-	-	5240	2950	8.2		
	-1.5 m	*6270	*6270	*10320	*10320	*11590	6600	8260	4460	5980	3330	-	-	5690	3180	7.7		
	-3 m	*11380	*11380	*15660	12430	*10930	6660	*8080	4490	-	-	-	-	*6660	3740	6.9		
-4.5 m	-	-	*12740	*12740	*9050	6870	-	-	-	-	-	-	*6920	5150	5.5			
GP Boom: 5.7 m HD Dipper arm: 2.9 m Shoe: 500 mm Counterweight: 5000 kg	7.5 m	-	-	-	-	-	-	*5150	*5150	-	-	-	-	*4900	*4900	6.1		
	6 m	-	-	-	-	-	-	*5050	*5050	-	-	-	-	*4570	3850	7.3		
	4.5 m	-	-	-	-	-	-	*5630	5160	*5320	3650	-	-	*4510	3270	8.0		
	3 m	-	-	-	-	*8410	7400	*6560	4920	*5720	3540	-	-	*4630	2980	8.3		
	1.5 m	-	-	-	-	*10320	6900	*7530	4670	6090	3420	-	-	*4940	2870	8.4		
	0 m	-	-	*5410	*5410	*11380	6630	*8230	4500	5990	3330	-	-	5210	2920	8.2		
	-1.5 m	*6260	*6260	*10310	*10310	*11540	6550	8220	4430	5960	3300	-	-	5660	3150	7.7		
	-3 m	*11370	*11370	*15600	12370	*10880	6620	*8050	4460	-	-	-	-	*6620	3710	6.9		
-4.5 m	-	-	*12680	*12680	*9000	6830	-	-	-	-	-	-	*6880	5120	5.5			

: Along undercarriage, : Across undercarriage, H : Lifting hook related to ground level

1. Machine in "Fine Mode-F" (Power Boost), for lifting capacities.
2. The above loads are in compliance with SAE and ISO Hydraulic Excavator Lift Capacity Standards.
3. Rated loads do not exceed 87% of hydraulic lifting capacity or 75% of tipping load.
4. Rated loads marked with an asterisk ( \* ) are limited by hydraulic capacity rather than tipping load.



Specifications  
Lifting capacities **451**

EC220E NL	H	1.5 m		3.0 m		4.5 m		6.0 m		7.5 m		9.0 m		Max. Reach		
																Max.
		kg	kg	kg	kg	kg	kg	kg	kg	kg	kg	kg	kg	kg	kg	m
<b>HD Boom: 5.7 m</b> <b>GP Dipper arm: 3.5 m</b> <b>Shoe: 500 mm</b> <b>Counterweight: 5000 kg</b>	7.5 m	-	-	-	-	-	-	-	-	-	-	-	-	*4910	4100	7.1
	6 m	-	-	-	-	-	-	-	-	*4620	3790	-	-	*4860	3280	8.1
	4.5 m	-	-	-	-	-	-	*4880	*4880	*4770	3730	-	-	*4910	2860	8.7
	3 m	-	-	-	-	-	-	*5750	5020	*5180	3590	4730	2680	4650	2640	9.0
	1.5 m	-	-	-	-	-	-	*6730	4730	*5690	3450	4660	2620	4530	2550	9.1
	0 m	-	-	-	-	-	-	*7530	4510	6000	3330	-	-	4620	2580	8.9
	-1.5 m	-	-	-	-	*10750	6500	*7940	4390	5920	3260	-	-	4940	2750	8.5
	-3 m	-	-	*15280	12110	*10470	6500	*7840	4380	5950	3280	-	-	5650	3140	7.7
	-4.5 m	*16740	*16740	*13000	12410	*9250	6650	*6830	4500	-	-	-	-	*5840	4000	6.6
<b>GP Boom: 5.7 m</b> <b>GP Dipper arm: 3.5 m</b> <b>Shoe: 500 mm</b> <b>Counterweight: 5000 kg</b>	7.5 m	-	-	-	-	-	-	-	-	-	-	-	-	*4940	4110	7.1
	6 m	-	-	-	-	-	-	-	-	*4650	3810	-	-	*4900	3300	8.1
	4.5 m	-	-	-	-	-	-	*4910	*4910	*4800	3740	-	-	*4950	2880	8.7
	3 m	-	-	-	-	-	-	*5790	5030	*5220	3620	4740	2710	4670	2660	9.0
	1.5 m	-	-	-	-	-	-	*6770	4760	*5730	3480	4680	2650	4550	2570	9.1
	0 m	-	-	-	-	-	-	*7580	4550	6020	3360	-	-	4640	2610	8.9
	-1.5 m	-	-	-	-	*10830	6560	*8010	4440	5950	3300	-	-	4960	2780	8.5
	-3 m	-	-	*15400	12230	*10550	6570	*7900	4430	5970	3320	-	-	5680	3170	7.7
	-4.5 m	*16740	*16740	*13110	12520	*9330	6710	*6880	4540	-	-	-	-	*5890	4040	6.6

: Along undercarriage, : Across undercarriage, H : Lifting hook related to ground level

1. Machine in "Fine Mode-F" (Power Boost), for lifting capacities.
2. The above loads are in compliance with SAE and ISO Hydraulic Excavator Lift Capacity Standards.
3. Rated loads do not exceed 87% of hydraulic lifting capacity or 75% of tipping load.
4. Rated loads marked with an asterisk ( \* ) are limited by hydraulic capacity rather than tipping load.



## Specifications 452 Lifting capacities

EC220E NL	H	3.0 m		4.5 m		6.0 m		7.5 m		9.0 m		Max. Reach		
														Max.
		kg	kg	kg	kg	kg	kg	kg	kg	kg	kg	kg	kg	m
VA Boom: 5.57 m ME Dipper arm: 2.0 m Shoe: 500 mm Counterweight: 5000 kg	7.5 m	-	-	*8600	8160	-	-	-	-	-	-	*8480	7380	4.7
	6 m	-	-	*8580	8090	*7470	5090	-	-	-	-	*7400	4840	6.1
	4.5 m	-	-	*9580	7650	*7670	4970	-	-	-	-	6950	3890	6.9
	3 m	-	-	*10890	7030	*8130	4720	-	-	-	-	6240	3460	7.4
	1.5 m	-	-	-	-	8390	4500	6030	3320	-	-	6020	3310	7.5
	0 m	-	-	*10870	6430	*8170	4370	-	-	-	-	6230	3400	7.2
	-1.5 m	-	-	*9360	6470	*7120	4380	-	-	-	-	*5890	3790	6.7
	-3 m	-	-	*6690	6650	-	-	-	-	-	-	-	-	5.7
VA Boom: 5.57 m HD Dipper arm: 2.5 m Shoe: 500 mm Counterweight: 5000 kg	7.5 m	-	-	*7840	-	-	-	-	-	-	-	*6800	6020	5.4
	6 m	-	-	*8000	*8000	*7020	5230	-	-	-	-	*6230	4280	6.7
	4.5 m	*12730	*12730	*9040	7860	*7360	5070	-	-	-	-	*6120	3550	7.4
	3 m	-	-	*10490	7240	*7930	4820	6190	3460	-	-	5720	3190	7.8
	1.5 m	-	-	*11420	6730	*8360	4570	6070	3350	-	-	5540	3060	7.9
	0 m	-	-	*11250	6490	8290	4410	5980	3280	-	-	5690	3130	7.7
	-1.5 m	*11490	*11490	*10080	6460	*7590	4370	-	-	-	-	*5700	3430	7.2
	-3 m	-	-	*7830	6590	*5670	4470	-	-	-	-	*5010	4180	6.3
VA Boom: 5.57 m GP Dipper arm: 2.9 m Shoe: 500 mm Counterweight: 5000 kg	9.0 m	-	-	-	-	-	-	-	-	-	-	*6130	*6130	4.0
	7.5 m	-	-	*7030	*7030	*5140	*5140	-	-	-	-	*4940	*4940	6.0
	6 m	-	-	*7080	*7080	*6680	5330	-	-	-	-	*4560	3900	7.2
	4.5 m	*9140	*9140	*8560	8020	*7090	5160	*6230	3610	-	-	*4470	3290	7.9
	3 m	-	-	*10090	7410	*7720	4890	6240	3500	-	-	*4570	2990	8.2
	1.5 m	-	-	*11260	6840	*8260	4620	6100	3370	-	-	*4850	2870	8.3
	0 m	*5940	*5940	*11410	6530	8320	4430	5990	3280	-	-	5300	2920	8.1
	-1.5 m	*10850	*10850	*10530	6450	*7870	4360	*5790	3260	-	-	*5490	3170	7.6
-3 m	*10990	*10990	*8600	6530	*6370	4410	-	-	-	-	*4980	3760	6.8	

: Along undercarriage, : Across undercarriage, H : Lifting hook related to ground level

1. Machine in "Fine Mode-F" (Power Boost), for lifting capacities.
2. The above loads are in compliance with SAE and ISO Hydraulic Excavator Lift Capacity Standards.
3. Rated loads do not exceed 87% of hydraulic lifting capacity or 75% of tipping load.
4. Rated loads marked with an asterisk ( \* ) are limited by hydraulic capacity rather than tipping load.





Specifications  
Lifting capacities **453**

EC220E NL	H	3.0 m		4.5 m		6.0 m		7.5 m		9.0 m		Max. Reach		
														Max.
		kg	kg	kg	kg	kg	kg	kg	kg	kg	kg	kg	kg	m
VA Boom: 5.57 m HD Dipper arm: 2.9 m Shoe: 500 mm Counterweight: 5000 kg	9.0 m	-	-	-	-	-	-	-	-	-	-	*6120	*6120	4.0
	7.5 m	-	-	*7020	*7020	*5120	*5120	-	-	-	-	*4930	*4930	6.0
	6 m	-	-	*7070	*7070	*6650	5310	-	-	-	-	*4550	3880	7.2
	4.5 m	*9120	*9120	*8530	8000	*7060	5130	*6200	3590	-	-	*4460	3270	7.9
	3 m	-	-	*10050	7370	*7690	4860	6220	3480	-	-	*4550	2960	8.2
	1.5 m	-	-	*11220	6800	*8230	4590	6070	3350	-	-	*4840	2850	8.3
	0 m	*5930	*5930	*11360	6490	8280	4400	5960	3250	-	-	5270	2890	8.1
	-1.5 m	*10840	*10840	*10480	6410	*7830	4320	*5760	3230	-	-	*5460	3140	7.6
-3 m	*10930	*10930	*8550	6490	*6340	4380	-	-	-	-	*4950	3730	6.8	
VA Boom: 5.57 m GP Dipper arm: 3.5 m Shoe: 500 mm Counterweight: 5000 kg	9.0 m	-	-	-	-	-	-	-	-	-	-	*7330	6350	5.3
	7.5 m	-	-	-	-	*6200	5500	-	-	-	-	*6250	4180	6.9
	6 m	-	-	-	-	*6070	5470	*5790	3760	-	-	*5790	3310	8.0
	4.5 m	-	-	-	-	*6420	5290	*5810	3700	-	-	5080	2870	8.6
	3 m	-	-	-	-	*7030	5000	*6040	3560	-	-	4720	2640	8.9
	1.5 m	-	-	-	-	*7640	4700	6140	3410	4660	2580	4600	2550	9.0
	0 m	-	-	-	-	*7940	4460	6000	3280	-	-	4690	2580	8.8
	-1.5 m	-	-	*10290	6420	*7720	4330	5930	3220	-	-	*4850	2770	8.4
-3 m	*11950	*11950	*8910	6430	*6750	4330	*4760	3260	-	-	*4420	3180	7.6	
-4.5 m	-	-	*6300	*6300	-	-	-	-	-	-	-	-	6.4	

: Along undercarriage, : Across undercarriage, H : Lifting hook related to ground level

1. Machine in "Fine Mode-F" (Power Boost), for lifting capacities.
2. The above loads are in compliance with SAE and ISO Hydraulic Excavator Lift Capacity Standards.
3. Rated loads do not exceed 87% of hydraulic lifting capacity or 75% of tipping load.
4. Rated loads marked with an asterisk ( \* ) are limited by hydraulic capacity rather than tipping load.





## Specifications 454 Lifting capacities

EC220E NL	H	1.5 m		3.0 m		4.5 m		6.0 m		7.5 m		9.0 m		Max. Reach		
																Max.
		kg	kg	kg	kg	kg	kg	kg	kg	kg	kg	kg	kg	kg	kg	m
HD Boom: 5.7 m ME Dipper arm: 2.0 m Shoe: 600 mm Counterweight: 5000 kg	7.5 m	-	-	-	-	-	-	-	-	-	-	-	-	*6270	*6270	4.9
	6 m	-	-	-	-	-	-	*6020	5190	-	-	-	-	*6060	4770	6.3
	4.5 m	-	-	-	-	*7650	*7650	*6410	5040	-	-	-	-	*6100	3880	7.1
	3 m	-	-	-	-	*9620	7110	*7210	4810	6190	3480	-	-	6170	3470	7.5
	1.5 m	-	-	-	-	-	-	*7980	4590	6090	3400	-	-	5970	3330	7.6
	0 m	-	-	-	-	*11520	6570	8320	4470	-	-	-	-	6160	3410	7.4
	-1.5 m	-	-	-	-	*11130	6600	*8290	4460	-	-	-	-	6880	3780	6.9
	-3 m	-	-	*13280	12670	*9870	6750	-	-	-	-	-	-	*7320	4730	5.9
HD Boom: 5.7 m HD Dipper arm: 2.5 m Shoe: 600 mm Counterweight: 5000 kg	7.5 m	-	-	-	-	-	-	-	-	-	-	-	-	*5640	*5640	5.6
	6 m	-	-	-	-	-	-	*5470	5300	-	-	-	-	*5570	4250	6.9
	4.5 m	-	-	-	-	*6960	*6960	*5990	5140	*5640	3630	-	-	*5650	3550	7.6
	3 m	-	-	-	-	*8960	7320	*6860	4890	*5950	3540	-	-	5670	3210	8
	1.5 m	-	-	-	-	*10700	6840	*7750	4660	6130	3430	-	-	5500	3080	8.1
	0 m	-	-	-	-	*11480	6630	*8330	4510	6040	3350	-	-	5640	3140	7.9
	-1.5 m	-	-	*10840	*10840	*11390	6600	8310	4460	-	-	-	-	6200	3430	7.4
	-3 m	-	-	*14640	12540	*10480	6700	*7730	4530	-	-	-	-	*6950	4130	6.5
HD Boom: 5.7 m HD Dipper arm: 2.9 m Shoe: 600 mm Counterweight: 5000 kg	-4.5 m	-	-	*11290	*11290	*8060	6980	-	-	-	-	-	-	*7090	6120	5
	7.5 m	-	-	-	-	-	-	*5130	*5130	-	-	-	-	*4900	*4900	6.2
	6 m	-	-	-	-	-	-	*5030	*5030	-	-	-	-	*4570	3860	7.3
	4.5 m	-	-	-	-	-	-	*5600	5190	*5280	3660	-	-	*4510	3280	8
	3 m	-	-	-	-	*8350	7440	*6510	4930	*5680	3550	-	-	*4630	2980	8.4
	1.5 m	-	-	-	-	*10250	6910	*7470	4680	6130	3420	-	-	*4940	2870	8.5
	0 m	-	-	*5410	*5410	*11290	6620	*8170	4500	6020	3330	-	-	*5240	2920	8.3
	-1.5 m	*6260	*6260	*10310	*10310	*11450	6540	8270	4420	5990	3300	-	-	5690	3150	7.8
HD Boom: 5.7 m GP Dipper arm: 2.9 m Shoe: 600 mm Counterweight: 5000 kg	-3 m	*11370	*11370	*15470	12370	*10790	6610	*7980	4460	-	-	-	-	*6570	3710	6.9
	-4.5 m	-	-	*12570	*12570	*8930	6830	-	-	-	-	-	-	*6820	5120	5.6
	7.5 m	-	-	-	-	-	-	*5150	*5150	-	-	-	-	*4910	*4910	6.2
	6 m	-	-	-	-	-	-	*5050	*5050	-	-	-	-	*4580	3890	7.3
	4.5 m	-	-	-	-	-	-	*5630	5220	*5310	3690	-	-	*4520	3300	8
	3 m	-	-	-	-	*8390	7470	*6550	4960	*5710	3580	-	-	*4640	3010	8.4
	1.5 m	-	-	-	-	*10300	6950	*7510	4710	6160	3450	-	-	*4950	2900	8.5
	0 m	-	-	*5420	*5420	*11340	6670	*8210	4530	6050	3360	-	-	5270	2940	8.3
-1.5 m	*6270	*6270	*10320	*10320	*11500	6590	8310	4460	6020	3330	-	-	5720	3180	7.8	
-3 m	*11380	*11380	*15530	12430	*10840	6650	*8020	4490	-	-	-	-	*6600	3740	6.9	
-4.5 m	-	-	*12620	*12620	*8970	6870	-	-	-	-	-	-	*6860	5150	5.6	

: Along undercarriage, : Across undercarriage, H : Lifting hook related to ground level

1. Machine in "Fine Mode-F" (Power Boost), for lifting capacities.
2. The above loads are in compliance with SAE and ISO Hydraulic Excavator Lift Capacity Standards.
3. Rated loads do not exceed 87% of hydraulic lifting capacity or 75% of tipping load.
4. Rated loads marked with an asterisk ( \* ) are limited by hydraulic capacity rather than tipping load.



**Specifications**  
**Lifting capacities**      **455**

EC220E NL	H	1.5 m		3.0 m		4.5 m		6.0 m		7.5 m		9.0 m		Max. Reach		
																Max.
		kg	kg	kg	kg	kg	kg	kg	kg	kg	kg	kg	kg	kg	kg	m
GP Boom: 5.7 m ME Dipper arm: 2.0 m Shoe: 600 mm Counterweight: 5000 kg	7.5 m	-	-	-	-	-	-	-	-	-	-	-	-	*6300	*6300	4.9
	6 m	-	-	-	-	-	-	*6050	5200	-	-	-	-	*6100	4790	6.3
	4.5 m	-	-	-	-	*7690	*7690	*6450	5060	-	-	-	-	*6140	3910	7.1
	3 m	-	-	-	-	*9680	7150	*7260	4840	6210	3510	-	-	6190	3500	7.5
	1.5 m	-	-	-	-	-	-	*8040	4630	6120	3430	-	-	5990	3360	7.6
	0 m	-	-	-	-	*11610	6640	8360	4520	-	-	-	-	6190	3450	7.4
	-1.5 m	-	-	-	-	*11220	6660	8350	4510	-	-	-	-	6910	3820	6.9
	-3 m	-	-	*13400	12770	*9960	6810	-	-	-	-	-	-	*7380	4780	5.9
GP Boom: 5.7 m HD Dipper arm: 2.5 m Shoe: 600 mm Counterweight: 5000 kg	7.5 m	-	-	-	-	-	-	-	-	-	-	-	-	*5670	*5670	5.6
	6 m	-	-	-	-	-	-	*5500	5310	-	-	-	-	*5600	4270	6.9
	4.5 m	-	-	-	-	*7000	*7000	*6020	5160	*5680	3650	-	-	*5690	3570	7.6
	3 m	-	-	-	-	*9020	7350	*6910	4920	*5990	3560	-	-	5690	3240	8
	1.5 m	-	-	-	-	*10780	6900	*7800	4700	6150	3460	-	-	5520	3120	8.1
	0 m	-	-	-	-	*11570	6690	*8390	4550	6070	3390	-	-	5670	3180	7.9
	-1.5 m	-	-	*10840	*10840	*11480	6660	8350	4510	-	-	-	-	6230	3470	7.4
	-3 m	-	-	*14760	12650	*10560	6760	*7790	4580	-	-	-	-	*7010	4170	6.5
-4.5 m	-	-	*11400	*11400	*8140	7030	-	-	-	-	-	-	*7150	6170	5	
GP Boom: 5.7 m HD Dipper arm: 2.9 m Shoe: 600 mm Counterweight: 5000 kg	7.5 m	-	-	-	-	-	-	*5150	*5150	-	-	-	-	*4900	*4900	6.2
	6 m	-	-	-	-	-	-	*5050	*5050	-	-	-	-	*4570	3880	7.3
	4.5 m	-	-	-	-	-	-	*5630	5210	*5320	3680	-	-	*4510	3300	8
	3 m	-	-	-	-	*8410	7460	*6560	4960	*5720	3580	-	-	*4630	3010	8.4
	1.5 m	-	-	-	-	*10320	6960	*7530	4710	6150	3460	-	-	*4940	2900	8.5
	0 m	-	-	*5410	*5410	*11380	6690	*8230	4540	6050	3360	-	-	5260	2950	8.3
	-1.5 m	*6260	*6260	*10310	*10310	*11540	6610	8310	4470	6020	3340	-	-	5720	3180	7.8
	-3 m	*11370	*11370	*15600	12480	*10880	6680	*8050	4500	-	-	-	-	*6620	3750	6.9
-4.5 m	-	-	*12680	*12680	*9000	6890	-	-	-	-	-	-	*6880	5170	5.6	
GP Boom: 5.7 m GP Dipper arm: 2.9 m Shoe: 600 mm Counterweight: 5000 kg	7.5 m	-	-	-	-	-	-	*5180	*5180	-	-	-	-	*4910	*4910	6.2
	6 m	-	-	-	-	-	-	*5080	*5080	-	-	-	-	*4580	3900	7.3
	4.5 m	-	-	-	-	-	-	*5660	5230	*5350	3710	-	-	*4520	3330	8
	3 m	-	-	-	-	*8440	7500	*6590	4990	*5750	3600	-	-	*4640	3030	8.4
	1.5 m	-	-	-	-	*10370	7000	*7570	4740	6180	3480	-	-	*4950	2930	8.5
	0 m	-	-	*5420	*5420	*11430	6730	*8270	4570	6080	3390	-	-	5290	2970	8.3
	-1.5 m	*6270	*6270	*10320	*10320	*11590	6660	8340	4500	6050	3360	-	-	5740	3210	7.8
	-3 m	*11380	*11380	*15660	12540	*10930	6720	*8080	4540	-	-	-	-	*6660	3770	6.9
-4.5 m	-	-	*12740	*12740	*9050	6930	-	-	-	-	-	-	*6920	5200	5.6	

: Along undercarriage, : Across undercarriage, H : Lifting hook related to ground level

1. Machine in "Fine Mode-F" (Power Boost), for lifting capacities.
2. The above loads are in compliance with SAE and ISO Hydraulic Excavator Lift Capacity Standards.
3. Rated loads do not exceed 87% of hydraulic lifting capacity or 75% of tipping load.
4. Rated loads marked with an asterisk ( \* ) are limited by hydraulic capacity rather than tipping load.

## Specifications 456 Lifting capacities

EC220E NL	H	1.5 m		3.0 m		4.5 m		6.0 m		7.5 m		9.0 m		Max. Reach		
																Max.
		kg	kg	kg	kg	kg	kg	kg	kg	kg	kg	kg	kg	kg	kg	m
<b>HD Boom: 5.7 m</b> <b>GP Dipper arm: 3.5 m</b> <b>Shoe: 600 mm</b> <b>Counterweight: 5000 kg</b>	7.5 m	-	-	-	-	-	-	-	-	-	-	-	-	*4910	4130	7.1
	6 m	-	-	-	-	-	-	-	-	*4620	3830	-	-	*4860	3310	8.1
	4.5 m	-	-	-	-	-	-	*4880	*4880	*4770	3760	-	-	*4910	2880	8.8
	3 m	-	-	-	-	-	-	*5750	5060	*5180	3630	4780	2710	4700	2660	9.1
	1.5 m	-	-	-	-	-	-	*6730	4770	*5690	3480	4710	2650	4580	2570	9.2
	0 m	-	-	-	-	-	-	*7530	4550	6060	3360	-	-	4670	2610	9
	-1.5 m	-	-	-	-	*10750	6560	*7940	4430	5980	3290	-	-	4990	2780	8.6
	-3 m	-	-	*15280	12220	*10470	6560	*7840	4420	6010	3310	-	-	*5710	3170	7.8
	-4.5 m	*16740	*16740	*13000	12520	*9250	6710	*6830	4540	-	-	-	-	*5840	4040	6.6
<b>GP Boom: 5.7 m</b> <b>GP Dipper arm: 3.5 m</b> <b>Shoe: 600 mm</b> <b>Counterweight: 5000 kg</b>	7.5 m	-	-	-	-	-	-	-	-	-	-	-	-	*4940	4140	7.1
	6 m	-	-	-	-	-	-	-	-	*4650	3840	-	-	*4900	3330	8.1
	4.5 m	-	-	-	-	-	-	*4910	*4910	*4800	3770	-	-	*4950	2910	8.8
	3 m	-	-	-	-	-	-	*5790	5080	*5220	3650	4790	2730	4720	2690	9.1
	1.5 m	-	-	-	-	-	-	*6770	4800	*5730	3510	4730	2680	4600	2600	9.2
	0 m	-	-	-	-	-	-	*7580	4590	6080	3390	-	-	4690	2630	9
	-1.5 m	-	-	-	-	*10830	6620	*8010	4480	6010	3330	-	-	5020	2810	8.6
	-3 m	-	-	*15400	12330	*10550	6630	*7900	4470	6030	3350	-	-	5740	3200	7.8
	-4.5 m	*16740	*16740	*13110	12630	*9330	6770	*6880	4580	-	-	-	-	*5890	4080	6.6

: Along undercarriage, : Across undercarriage, H : Lifting hook related to ground level

1. Machine in "Fine Mode-F" (Power Boost), for lifting capacities.
2. The above loads are in compliance with SAE and ISO Hydraulic Excavator Lift Capacity Standards.
3. Rated loads do not exceed 87% of hydraulic lifting capacity or 75% of tipping load.
4. Rated loads marked with an asterisk ( \* ) are limited by hydraulic capacity rather than tipping load.



**Specifications**  
**Lifting capacities**      **457**

EC220E NL	H	3.0 m		4.5 m		6.0 m		7.5 m		9.0 m		Max. Reach		
														Max.
		kg	kg	kg	kg	kg	kg	kg	kg	kg	kg	kg	kg	m
VA Boom: 5.57 m ME Dipper arm: 2.0 m Shoe: 600 mm Counterweight: 5000 kg	7.5 m	-	-	*8600	8220	-	-	-	-	-	-	*8480	7440	4.8
	6 m	-	-	*8580	8150	*7470	5140	-	-	-	-	*7400	4880	6.2
	4.5 m	-	-	*9580	7710	*7670	5010	-	-	-	-	*6960	3930	7
	3 m	-	-	*10890	7090	*8130	4760	-	-	-	-	6300	3490	7.4
	1.5 m	-	-	-	-	*8410	4540	6090	3350	-	-	6080	3340	7.5
	0 m	-	-	*10870	6490	*8170	4420	-	-	-	-	6290	3430	7.3
	-1.5 m	-	-	*9360	6530	*7120	4420	-	-	-	-	*5890	3830	6.7
	-3 m	-	-	*6690	*6690	-	-	-	-	-	-	-	-	-
VA Boom: 5.57 m HD Dipper arm: 2.5 m Shoe: 600 mm Counterweight: 5000 kg	7.5 m	-	-	*7840	*7840	-	-	-	-	-	-	*6800	6060	5.5
	6 m	-	-	*8000	*8000	*7020	5270	-	-	-	-	*6230	4320	6.7
	4.5 m	*12730	*12730	*9040	7920	*7360	5110	-	-	-	-	*6120	3580	7.5
	3 m	-	-	*10490	7310	*7930	4860	6250	3490	-	-	5780	3220	7.9
	1.5 m	-	-	*11420	6790	*8360	4610	6130	3380	-	-	5590	3090	8
	0 m	-	-	*11250	6550	*8330	4450	6050	3310	-	-	5750	3160	7.8
	-1.5 m	*11490	*11490	*10080	6520	*7590	4410	-	-	-	-	*5700	3460	7.3
	-3 m	-	-	*7830	6650	*5670	4510	-	-	-	-	*5010	4220	6.3
VA Boom: 5.57 m HD Dipper arm: 2.9 m Shoe: 600 mm Counterweight: 5000 kg	9.0 m	-	-	-	-	-	-	-	-	-	-	*6120	*6120	4
	7.5 m	-	-	*7020	*7020	*5120	*5120	-	-	-	-	*4930	*4930	6
	6 m	-	-	*7070	*7070	*6650	5350	-	-	-	-	*4550	3910	7.2
	4.5 m	*9120	*9120	*8530	8060	*7060	5180	*6200	3620	-	-	*4460	3300	7.9
	3 m	-	-	*10050	7440	*7690	4910	6280	3510	-	-	*4550	2990	8.3
	1.5 m	-	-	*11220	6860	*8230	4630	6130	3380	-	-	*4840	2870	8.4
	0 m	*5930	*5930	*11360	6550	*8350	4440	6020	3280	-	-	5330	2920	8.2
	-1.5 m	*10840	*10840	*10480	6470	*7830	4370	*5760	3260	-	-	*5460	3170	7.7
-3 m	*10930	*10930	*8550	6550	*6340	4420	-	-	-	-	*4950	3770	6.8	

: Along undercarriage, : Across undercarriage, H : Lifting hook related to ground level

1. Machine in "Fine Mode-F" (Power Boost), for lifting capacities.
2. The above loads are in compliance with SAE and ISO Hydraulic Excavator Lift Capacity Standards.
3. Rated loads do not exceed 87% of hydraulic lifting capacity or 75% of tipping load.
4. Rated loads marked with an asterisk ( \* ) are limited by hydraulic capacity rather than tipping load.

## Specifications 458 Lifting capacities

EC220E NL	H	3.0 m		4.5 m		6.0 m		7.5 m		9.0 m		Max. Reach		
														Max.
		kg	kg	kg	kg	kg	kg	kg	kg	kg	kg	kg	kg	m
VA Boom: 5.57 m GP Dipper arm: 2.9 m Shoe: 600 mm Counterweight: 5000 kg	9.0 m	-	-	-	-	-	-	-	-	-	-	*6130	*6130	4
	7.5 m	-	-	*7030	*7030	*5140	*5140	-	-	-	-	*4940	*4940	6
	6 m	-	-	*7080	*7080	*6680	5370	-	-	-	-	*4560	3940	7.2
	4.5 m	*9140	*9140	*8560	8080	*7090	5200	*6230	3640	-	-	*4470	3320	7.9
	3 m	-	-	*10090	7470	*7720	4930	6300	3530	-	-	*4570	3010	8.3
	1.5 m	-	-	*11260	6900	*8260	4670	6160	3410	-	-	*4850	2900	8.4
	0 m	*5940	*5940	*11410	6590	*8390	4480	6050	3310	-	-	5360	2950	8.2
	-1.5 m	*10850	*10850	*10530	6510	*7870	4400	*5790	3290	-	-	*5490	3200	7.7
	-3 m	*10990	*10990	*8600	6590	*6370	4450	-	-	-	-	*4980	3790	6.8
VA Boom: 5.57 m GP Dipper arm: 3.5 m Shoe: 600 mm Counterweight: 5000 kg	9.0 m	-	-	-	-	-	-	-	-	-	-	*7330	6400	5.4
	7.5 m	-	-	-	-	*6200	5540	-	-	-	-	*6250	4220	7
	6 m	-	-	-	-	*6070	5510	*5790	3790	-	-	*5790	3340	8
	4.5 m	-	-	-	-	*6420	5330	*5810	3730	-	-	5140	2900	8.6
	3 m	-	-	-	-	*7030	5040	*6040	3590	-	-	4770	2660	9
	1.5 m	-	-	-	-	*7640	4740	6200	3440	4700	2610	4650	2570	9.1
	0 m	-	-	-	-	*7940	4500	6060	3310	-	-	4740	2610	8.9
	-1.5 m	-	-	*10290	6480	*7720	4380	*5990	3250	-	-	*4850	2790	8.4
	-3 m	*11950	*11950	*8910	6490	*6750	4370	*4760	3290	-	-	*4420	3210	7.7
-4.5 m	-	-	*6300	*6300	-	-	-	-	-	-	-	-	6.5	

: Along undercarriage, : Across undercarriage, H : Lifting hook related to ground level

1. Machine in "Fine Mode-F" (Power Boost), for lifting capacities.
2. The above loads are in compliance with SAE and ISO Hydraulic Excavator Lift Capacity Standards.
3. Rated loads do not exceed 87% of hydraulic lifting capacity or 75% of tipping load.
4. Rated loads marked with an asterisk ( \* ) are limited by hydraulic capacity rather than tipping load.



Specifications  
Lifting capacities 459

EC220E NH	H	1.5 m		3.0 m		4.5 m		6.0 m		7.5 m		9.0 m		Max. Reach		
																Max.
		kg	kg	kg	kg	kg	kg	kg	kg	kg	kg	kg	kg	kg	kg	m
HD Boom: 5.7 m ME Dipper arm: 2.0 m Shoe: 500 mm Counterweight: 5000 kg	7.5 m	-	-	-	-	-	-	-	-	-	-	-	-	*6270	*6270	4.9
	6 m	-	-	-	-	-	-	*6020	5320	-	-	-	-	*6060	4900	6.3
	4.5 m	-	-	-	-	*7650	*7650	*6410	5170	-	-	-	-	*6100	3990	7.1
	3 m	-	-	-	-	*9620	7300	*7210	4930	6010	3580	-	-	5990	3570	7.5
	1.5 m	-	-	-	-	-	-	*7980	4720	5910	3490	-	-	5790	3420	7.6
	0 m	-	-	-	-	*11520	6760	8040	4600	-	-	-	-	5970	3510	7.4
	-1.5 m	-	-	-	-	*11130	6790	8030	4590	-	-	-	-	6660	3890	6.9
	-3 m	-	-	*13280	13040	*9870	6940	-	-	-	-	-	-	*7320	4870	5.9
HD Boom: 5.7 m HD Dipper arm: 2.5 m Shoe: 500 mm Counterweight: 5000 kg	7.5 m	-	-	-	-	-	-	-	-	-	-	-	-	*5640	*5640	5.6
	6 m	-	-	-	-	-	-	*5470	5430	-	-	-	-	*5570	4360	6.9
	4.5 m	-	-	-	-	*6960	*6960	*5990	5270	*5640	3720	-	-	*5650	3650	7.6
	3 m	-	-	-	-	*8960	7510	*6860	5020	*5950	3630	-	-	5510	3300	8
	1.5 m	-	-	-	-	*10700	7030	*7750	4790	5950	3530	-	-	5340	3170	8.1
	0 m	-	-	-	-	*11480	6820	8080	4640	5860	3450	-	-	5480	3240	7.9
	-1.5 m	-	-	*10840	*10840	*11390	6790	8020	4590	-	-	-	-	6010	3530	7.4
	-3 m	-	-	*14640	12910	*10480	6890	*7730	4660	-	-	-	-	*6950	4250	6.5
-4.5 m	-	-	*11290	*11290	*8060	7170	-	-	-	-	-	-	*7090	6290	5	
HD Boom: 5.7 m HD Dipper arm: 2.9 m Shoe: 500 mm Counterweight: 5000 kg	7.5 m	-	-	-	-	-	-	*5130	*5130	-	-	-	-	*4900	*4900	6.2
	6 m	-	-	-	-	-	-	*5030	*5030	-	-	-	-	*4570	3960	7.3
	4.5 m	-	-	-	-	-	-	*5600	5320	*5280	3760	-	-	*4510	3370	8
	3 m	-	-	-	-	*8350	7630	*6510	5060	*5680	3650	-	-	*4630	3070	8.4
	1.5 m	-	-	-	-	*10250	7100	*7470	4810	5950	3520	-	-	*4940	2960	8.5
	0 m	-	-	*5410	*5410	*11290	6810	8070	4630	5840	3430	-	-	*5090	3000	8.3
	-1.5 m	*6260	*6260	*10310	*10310	*11450	6740	7990	4550	5810	3400	-	-	5520	3240	7.8
	-3 m	*11370	*11370	*15470	12730	*10790	6800	*7980	4590	-	-	-	-	6540	3810	6.9
-4.5 m	-	-	*12570	*12570	*8930	7020	-	-	-	-	-	-	*6820	5270	5.6	
HD Boom: 5.7 m GP Dipper arm: 2.9 m Shoe: 500 mm Counterweight: 5000 kg	7.5 m	-	-	-	-	-	-	*5150	*5150	-	-	-	-	*4910	*4910	6.2
	6 m	-	-	-	-	-	-	*5050	*5050	-	-	-	-	*4580	3990	7.3
	4.5 m	-	-	-	-	-	-	*5630	5350	*5310	3780	-	-	*4520	3390	8
	3 m	-	-	-	-	*8390	7660	*6550	5090	*5710	3670	-	-	*4640	3090	8.4
	1.5 m	-	-	-	-	*10300	7140	*7510	4840	5970	3550	-	-	*4950	2980	8.5
	0 m	-	-	*5420	*5420	*11340	6860	8110	4660	5870	3460	-	-	5120	3030	8.3
	-1.5 m	*6270	*6270	*10320	*10320	*11500	6780	8020	4580	5840	3430	-	-	5550	3270	7.8
	-3 m	*11380	*11380	*15530	12800	*10840	6840	*8020	4620	-	-	-	-	6560	3840	6.9
-4.5 m	-	-	*12620	*12620	*8970	7060	-	-	-	-	-	-	*6860	5300	5.6	

: Along undercarriage, : Across undercarriage, H : Lifting hook related to ground level

1. Machine in "Fine Mode-F" (Power Boost), for lifting capacities.
2. The above loads are in compliance with SAE and ISO Hydraulic Excavator Lift Capacity Standards.
3. Rated loads do not exceed 87% of hydraulic lifting capacity or 75% of tipping load.
4. Rated loads marked with an asterisk ( \* ) are limited by hydraulic capacity rather than tipping load.





## Specifications 460 Lifting capacities

EC220E NH	H	1.5 m		3.0 m		4.5 m		6.0 m		7.5 m		9.0 m		Max. Reach		
																Max.
		kg	kg	kg	kg	kg	kg	kg	kg	kg	kg	kg	kg	kg	kg	kg
GP Boom: 5.7 m ME Dipper arm: 2.0 m Shoe: 500 mm Counterweight: 5000 kg	7.5 m	-	-	-	-	-	-	-	-	-	-	-	-	*6300	*6300	4.9
	6 m	-	-	-	-	-	-	*6050	5330	-	-	-	-	*6100	4920	6.3
	4.5 m	-	-	-	-	*7690	*7690	*6450	5190	-	-	-	-	*6140	4010	7.1
	3 m	-	-	-	-	*9680	7350	*7260	4970	6030	3610	-	-	6010	3600	7.5
	1.5 m	-	-	-	-	-	-	*8040	4760	5940	3530	-	-	5810	3460	7.6
	0 m	-	-	-	-	*11610	6830	8070	4650	-	-	-	-	6000	3550	7.4
	-1.5 m	-	-	-	-	*11220	6850	8070	4640	-	-	-	-	6690	3930	6.9
	-3 m	-	-	*13400	13140	*9960	7000	-	-	-	-	-	-	*7380	4910	5.9
GP Boom: 5.7 m HD Dipper arm: 2.5 m Shoe: 500 mm Counterweight: 5000 kg	7.5 m	-	-	-	-	-	-	-	-	-	-	-	-	*5670	*5670	5.6
	6 m	-	-	-	-	-	-	*5500	5440	-	-	-	-	*5600	4380	6.9
	4.5 m	-	-	-	-	*7000	*7000	*6020	5290	*5680	3750	-	-	*5690	3670	7.6
	3 m	-	-	-	-	*9020	7550	*6910	5050	*5990	3660	-	-	5530	3330	8
	1.5 m	-	-	-	-	*10780	7090	*7800	4830	5970	3560	-	-	5360	3210	8.1
	0 m	-	-	-	-	*11570	6880	8110	4680	5890	3490	-	-	5500	3270	7.9
	-1.5 m	-	-	*10840	*10840	*11480	6860	8060	4640	-	-	-	-	6040	3570	7.4
	-3 m	-	-	*14760	13020	*10560	6950	*7790	4710	-	-	-	-	*7010	4290	6.5
GP Boom: 5.7 m HD Dipper arm: 2.9 m Shoe: 500 mm Counterweight: 5000 kg	-4.5 m	-	-	*11400	*11400	*8140	7220	-	-	-	-	-	-	*7150	6330	5
	7.5 m	-	-	-	-	-	-	*5150	*5150	-	-	-	-	*4900	*4900	6.2
	6 m	-	-	-	-	-	-	*5050	*5050	-	-	-	-	*4570	3980	7.3
	4.5 m	-	-	-	-	-	-	*5630	5340	*5320	3780	-	-	*4510	3390	8
	3 m	-	-	-	-	*8410	7660	*6560	5090	*5720	3670	-	-	*4630	3100	8.4
	1.5 m	-	-	-	-	*10320	7150	*7530	4840	5970	3550	-	-	*4940	2980	8.5
	0 m	-	-	*5410	*5410	*11380	6880	8110	4670	5870	3460	-	-	*5110	3030	8.3
	-1.5 m	*6260	*6260	*10310	*10310	*11540	6800	8020	4600	5840	3430	-	-	5550	3280	7.8
GP Boom: 5.7 m GP Dipper arm: 2.9 m Shoe: 500 mm Counterweight: 5000 kg	-3 m	*11370	*11370	*15600	12850	*10880	6870	*8050	4630	-	-	-	-	6570	3850	6.9
	-4.5 m	-	-	*12680	*12680	*9000	7080	-	-	-	-	-	-	*6880	5310	5.6
	7.5 m	-	-	-	-	-	-	*5180	*5180	-	-	-	-	*4910	*4910	6.2
	6 m	-	-	-	-	-	-	*5080	*5080	-	-	-	-	*4580	4000	7.3
	4.5 m	-	-	-	-	-	-	*5660	5360	*5350	3800	-	-	*4520	3420	8
	3 m	-	-	-	-	*8440	7690	*6590	5120	*5750	3700	-	-	*4640	3120	8.4
	1.5 m	-	-	-	-	*10370	7190	*7570	4870	6000	3580	-	-	*4950	3010	8.5
	0 m	-	-	*5420	*5420	*11430	6920	8140	4700	5900	3490	-	-	5140	3060	8.3
GP Boom: 5.7 m GP Dipper arm: 2.9 m Shoe: 500 mm Counterweight: 5000 kg	-1.5 m	*6270	*6270	*10320	*10320	*11590	6850	8060	4630	5860	3460	-	-	5580	3300	7.8
	-3 m	*11380	*11380	*15660	12910	*10930	6910	*8080	4670	-	-	-	-	6590	3880	6.9
	-4.5 m	-	-	*12740	*12740	*9050	7120	-	-	-	-	-	-	*6920	5340	5.6

: Along undercarriage, : Across undercarriage, H : Lifting hook related to ground level

1. Machine in "Fine Mode-F" (Power Boost), for lifting capacities.
2. The above loads are in compliance with SAE and ISO Hydraulic Excavator Lift Capacity Standards.
3. Rated loads do not exceed 87% of hydraulic lifting capacity or 75% of tipping load.
4. Rated loads marked with an asterisk ( \* ) are limited by hydraulic capacity rather than tipping load.



Specifications  
Lifting capacities **461**

EC220E NH	H	1.5 m		3.0 m		4.5 m		6.0 m		7.5 m		9.0 m		Max. Reach		
																Max.
		kg	kg	kg	kg	kg	kg	kg	kg	kg	kg	kg	kg	kg	kg	m
<b>HD Boom: 5.7 m</b> <b>GP Dipper arm: 3.5 m</b> <b>Shoe: 500 mm</b> <b>Counterweight: 5000 kg</b>	7.5 m	-	-	-	-	-	-	-	-	-	-	-	-	*4910	4230	7.1
	6 m	-	-	-	-	-	-	-	-	*4620	3920	-	-	*4860	3400	8.1
	4.5 m	-	-	-	-	-	-	*4880	*4880	*4770	3860	-	-	4910	2970	8.8
	3 m	-	-	-	-	-	-	*5750	5190	*5180	3730	4640	2790	4570	2740	9.1
	1.5 m	-	-	-	-	-	-	*6730	4900	*5690	3580	4580	2730	4450	2650	9.2
	0 m	-	-	-	-	-	-	*7530	4680	5870	3460	-	-	4530	2680	9
	-1.5 m	-	-	-	-	*10750	6750	*7940	4560	5800	3390	-	-	4850	2860	8.6
	-3 m	-	-	*15280	12580	*10470	6750	*7840	4550	5830	3410	-	-	5540	3260	7.8
-4.5 m	*16740	*16740	*13000	12890	*9250	6900	*6830	4670	-	-	-	-	*5840	4150	6.6	
<b>GP Boom: 5.7 m</b> <b>GP Dipper arm: 3.5 m</b> <b>Shoe: 500 mm</b> <b>Counterweight: 5000 kg</b>	7.5 m	-	-	-	-	-	-	-	-	-	-	-	-	*4940	4250	7.1
	6 m	-	-	-	-	-	-	-	-	*4650	3940	-	-	*4900	3420	8.1
	4.5 m	-	-	-	-	-	-	*4910	*4910	*4800	3870	-	-	4920	2990	8.8
	3 m	-	-	-	-	-	-	*5790	5210	*5220	3750	4660	2810	4590	2760	9.1
	1.5 m	-	-	-	-	-	-	*6770	4930	*5730	3610	4600	2750	4470	2680	9.2
	0 m	-	-	-	-	-	-	*7580	4720	5900	3490	-	-	4560	2710	9
	-1.5 m	-	-	-	-	*10830	6820	*8010	4610	5830	3430	-	-	4870	2890	8.6
	-3 m	-	-	*15400	12700	*10550	6820	*7900	4600	5850	3450	-	-	5570	3300	7.8
-4.5 m	*16740	*16740	*13110	13000	*9330	6970	*6880	4710	-	-	-	-	*5890	4190	6.6	

: Along undercarriage, : Across undercarriage, H : Lifting hook related to ground level

1. Machine in "Fine Mode-F" (Power Boost), for lifting capacities.
2. The above loads are in compliance with SAE and ISO Hydraulic Excavator Lift Capacity Standards.
3. Rated loads do not exceed 87% of hydraulic lifting capacity or 75% of tipping load.
4. Rated loads marked with an asterisk ( \* ) are limited by hydraulic capacity rather than tipping load.



## Specifications 462 Lifting capacities

EC220E NH	H	3.0 m		4.5 m		6.0 m		7.5 m		9.0 m		Max. Reach		
														Max.
		kg	kg	kg	kg	kg	kg	kg	kg	kg	kg	kg	kg	m
VA Boom: 5.57 m ME Dipper arm: 2.0 m Shoe: 500 mm Counterweight: 5000 kg	7.5 m	-	-	*8600	8410	-	-	-	-	-	-	*8480	7620	4.8
	6 m	-	-	*8580	8350	*7470	5270	-	-	-	-	*7400	5010	6.2
	4.5 m	-	-	*9580	7900	*7670	5140	-	-	-	-	6800	4030	7
	3 m	-	-	*10890	7280	*8130	4890	-	-	-	-	6100	3590	7.4
	1.5 m	-	-	-	-	8180	4670	5900	3450	-	-	5900	3440	7.5
	0 m	-	-	*10870	6690	8040	4550	-	-	-	-	6090	3530	7.3
	-1.5 m	-	-	*9360	6720	*7120	4550	-	-	-	-	*5890	3940	6.7
	-3 m	-	-	*6690	*6690	-	-	-	-	-	-	-	-	-
VA Boom: 5.57 m HD Dipper arm: 2.5 m Shoe: 500 mm Counterweight: 5000 kg	7.5 m	-	-	*7840	*7840	-	-	-	-	-	-	*6800	6210	5.5
	6 m	-	-	*8000	*8000	*7020	5400	-	-	-	-	*6230	4430	6.7
	4.5 m	*12730	*12730	*9040	8110	*7360	5250	-	-	-	-	*6120	3680	7.5
	3 m	-	-	*10490	7500	*7930	4990	6060	3590	-	-	5600	3310	7.9
	1.5 m	-	-	*11420	6980	8260	4740	5940	3480	-	-	5430	3180	8
	0 m	-	-	*11250	6740	8080	4580	5860	3410	-	-	5570	3250	7.8
	-1.5 m	*11490	*11490	*10080	6710	*7590	4540	-	-	-	-	*5700	3560	7.3
	-3 m	-	-	*7830	6840	*5670	4640	-	-	-	-	*5010	4340	6.3
VA Boom: 5.57 m HD Dipper arm: 2.9 m Shoe: 500 mm Counterweight: 5000 kg	9.0 m	-	-	-	-	-	-	-	-	-	-	*6120	*6120	4
	7.5 m	-	-	*7020	*7020	*5120	*5120	-	-	-	-	*4930	*4930	6
	6 m	-	-	*7070	*7070	*6650	5480	-	-	-	-	*4550	4020	7.2
	4.5 m	*9120	*9120	*8530	8250	*7060	5310	*6200	3720	-	-	*4460	3390	7.9
	3 m	-	-	*10050	7630	*7690	5040	6090	3610	-	-	*4550	3080	8.3
	1.5 m	-	-	*11220	7050	*8230	4760	5940	3480	-	-	*4840	2960	8.4
	0 m	*5930	*5930	*11360	6740	8070	4570	5840	3380	-	-	5170	3010	8.2
	-1.5 m	*10840	*10840	*10480	6660	*7830	4500	*5760	3360	-	-	*5460	3270	7.7
-3 m	*10930	*10930	*8550	6740	*6340	4550	-	-	-	-	*4950	3880	6.8	

: Along undercarriage, : Across undercarriage, H : Lifting hook related to ground level

1. Machine in "Fine Mode-F" (Power Boost), for lifting capacities.
2. The above loads are in compliance with SAE and ISO Hydraulic Excavator Lift Capacity Standards.
3. Rated loads do not exceed 87% of hydraulic lifting capacity or 75% of tipping load.
4. Rated loads marked with an asterisk ( \* ) are limited by hydraulic capacity rather than tipping load.



Specifications  
Lifting capacities **463**

EC220E NH	H	3.0 m		4.5 m		6.0 m		7.5 m		9.0 m		Max. Reach		
														Max.
		kg	kg	kg	kg	kg	kg	kg	kg	kg	kg	kg	kg	m
VA Boom: 5.57 m GP Dipper arm: 2.9 m Shoe: 500 mm Counterweight: 5000 kg	9.0 m	-	-	-	-	-	-	-	-	-	-	*6130	*6130	4
	7.5 m	-	-	*7030	*7030	*5140	*5140	-	-	-	-	*4940	*4940	6
	6 m	-	-	*7080	*7080	*6680	5500	-	-	-	-	*4560	4040	7.2
	4.5 m	*9140	*9140	*8560	8280	*7090	5330	*6230	3740	-	-	*4470	3410	7.9
	3 m	-	-	*10090	7660	*7720	5060	6110	3630	-	-	*4570	3100	8.3
	1.5 m	-	-	*11260	7090	*8260	4800	5970	3500	-	-	*4850	2990	8.4
	0 m	*5940	*5940	*11410	6790	8110	4610	5860	3410	-	-	5200	3040	8.2
	-1.5 m	*10850	*10850	*10530	6700	*7870	4530	*5790	3390	-	-	*5490	3290	7.7
-3 m	*10990	*10990	*8600	6790	*6370	4580	-	-	-	-	*4980	3900	6.8	
VA Boom: 5.57 m GP Dipper arm: 3.5 m Shoe: 500 mm Counterweight: 5000 kg	9.0 m	-	-	-	-	-	-	-	-	-	-	*7330	6550	5.4
	7.5 m	-	-	-	-	*6200	5670	-	-	-	-	*6250	4320	7
	6 m	-	-	-	-	*6070	5650	*5790	3890	-	-	5700	3430	8
	4.5 m	-	-	-	-	*6420	5460	*5810	3830	-	-	4990	2980	8.6
	3 m	-	-	-	-	*7030	5170	*6040	3690	-	-	4640	2740	9
	1.5 m	-	-	-	-	*7640	4870	6010	3540	4570	2680	4520	2650	9.1
	0 m	-	-	-	-	*7940	4630	5870	3410	-	-	4600	2690	8.9
	-1.5 m	-	-	*10290	6670	*7720	4510	5800	3350	-	-	*4850	2880	8.4
-3 m	*11950	*11950	*8910	6690	*6750	4500	*4760	3390	-	-	*4420	3310	7.7	
-4.5 m	-	-	*6300	*6300	-	-	-	-	-	-	-	-	-	6.5

: Along undercarriage, : Across undercarriage, H : Lifting hook related to ground level

1. Machine in "Fine Mode-F" (Power Boost), for lifting capacities.
2. The above loads are in compliance with SAE and ISO Hydraulic Excavator Lift Capacity Standards.
3. Rated loads do not exceed 87% of hydraulic lifting capacity or 75% of tipping load.
4. Rated loads marked with an asterisk ( \* ) are limited by hydraulic capacity rather than tipping load.



## Specifications 464 Lifting capacities

EC220E LR	H	1.5 m		3.0 m		4.5 m		6.0 m		7.5 m		9.0 m	
		kg	kg	kg	kg	kg	kg	kg	kg	kg	kg	kg	kg
LR Boom: 8.85 m LR Dipper arm: 6.25 m Shoe: 800 mm Counterweight: 5000 kg	12 m	-	-	-	-	-	-	-	-	-	-	-	-
	10.5 m	-	-	-	-	-	-	-	-	-	-	-	-
	9.0 m	-	-	-	-	-	-	-	-	-	-	-	-
	7.5 m	-	-	-	-	-	-	-	-	-	-	-	-
	6 m	-	-	-	-	-	-	-	-	-	-	-	-
	4.5 m	-	-	-	-	-	-	-	-	-	-	-	-
	3 m	-	-	-	-	*6300	*6300	*4590	*4590	*3720	*3720	*3210	3070
	1.5 m	-	-	-	-	*7880	7320	*5580	5020	*4330	3700	*3600	2850
	0 m	-	-	*2480	*2480	*5610	*5610	*6360	4570	*4860	3410	*3970	2650
	-1.5 m	*2650	*2650	*3360	*3360	*5620	*5620	*6860	4290	*5250	3200	4140	2500
	-3 m	*3570	*3570	*4340	*4340	*6320	6270	*7110	4160	5210	3070	4030	2400
	-4.5 m	*4530	*4530	*5410	*5410	*7370	6290	*7120	4120	5150	3020	3980	2350
	-6 m	*5560	*5560	*6600	*6600	*8740	6410	*6920	4160	5160	3030	3980	2350
	-7.5 m	*6670	*6670	*7960	*7960	*8470	6590	*6480	4270	*5170	3100	4040	2410
-9.0 m	-	-	*9560	*9560	*7360	6870	*5710	4450	*4560	3240	*3640	2540	
-10.5 m	-	-	-	-	*5630	*5630	*4390	*4390	*3350	*3350	-	-	

EC220E LR	H	10.5 m		12 m		13.5 m		Max. Reach		Max. m
		kg	kg	kg	kg	kg	kg	kg	kg	
LR Boom: 8.85 m LR Dipper arm: 6.25 m Shoe: 800 mm Counterweight: 5000 kg	12 m	-	-	-	-	-	-	*870	*870	10.3
	10.5 m	-	-	-	-	-	-	*800	*800	11.6
	9.0 m	-	-	*1450	*1450	-	-	*760	*760	12.6
	7.5 m	*2230	*2230	*2060	*2060	-	-	*740	*740	13.4
	6 m	*2390	*2390	*2330	2070	*1330	*1330	*740	*740	13.9
	4.5 m	*2610	2530	*2470	1980	*1810	1560	*750	*750	14.3
	3 m	*2870	2390	*2640	1890	*2160	1500	*780	*780	14.5
	1.5 m	*3140	2240	*2830	1790	2400	1440	*820	*820	14.6
	0 m	*3390	2110	2820	1700	2340	1390	*880	*880	14.4
	-1.5 m	3330	2000	2740	1630	2300	1350	*970	*970	14.2
	-3 m	3250	1930	2690	1580	*1670	1320	*1100	*1100	13.7
	-4.5 m	3210	1890	2670	1570	-	-	*1280	*1280	13.1
	-6 m	3220	1900	*2410	1590	-	-	*1560	1550	12.3
	-7.5 m	3290	1970	-	-	-	-	*2030	1830	11.2
-9.0 m	-	-	-	-	-	-	*3020	2320	9.7	
-10.5 m	-	-	-	-	-	-	*3250	*3250	7.6	

: Along undercarriage, : Across undercarriage, H : Lifting hook related to ground level

1. Machine in "Fine Mode-F" (Power Boost), for lifting capacities.
2. The above loads are in compliance with SAE and ISO Hydraulic Excavator Lift Capacity Standards.
3. Rated loads do not exceed 87% of hydraulic lifting capacity or 75% of tipping load.
4. Rated loads marked with an asterisk ( \* ) are limited by hydraulic capacity rather than tipping load.



Specifications  
Lifting capacities 465

For North America

EC220E L	H	5 ft		10 ft		15 ft		20 ft		25 ft		30 ft		Max. Reach		
																Max.
		lb	lb	lb	lb	lb	lb	lb	lb	lb	lb	lb	lb	lb	lb	ft
GP Boom: 5.7 m (18' 8") ME Dipper arm: 2.0 m (6' 7") Shoe: 800 mm (2' 8") Counterweight: 4200 kg (9260 lb)	25 ft	-	-	-	-	-	-	-	-	-	-	-	-	*13990	*13990	15.7
	20 ft	-	-	-	-	-	-	*13390	12210	-	-	-	-	*13460	11750	20.5
	15 ft	-	-	-	-	*16580	*16580	*14060	11950	-	-	-	-	*13540	9470	23.2
	10 ft	-	-	-	-	*20810	17220	*15750	11450	-	-	-	-	13030	8440	24.6
	5 ft	-	-	-	-	-	-	17430	11000	-	-	-	-	12570	8100	25
	0 ft	-	-	-	-	*25160	16000	17130	10740	-	-	-	-	12970	8310	24.3
	-5 ft	-	-	-	-	*24340	16050	17120	10720	-	-	-	-	14540	9250	22.4
	-10 ft	-	-	*29080	*29080	*21510	16390	-	-	-	-	-	-	*16290	11710	19.1
GP Boom: 5.7 m (18' 8") HD Dipper arm: 2.5 m (8' 2") Shoe: 800 mm (2' 8") Counterweight: 4200 kg (9260 lb)	25 ft	-	-	-	-	-	-	-	-	-	-	-	-	*12540	*12540	18
	20 ft	-	-	-	-	-	-	*12110	*12110	-	-	-	-	*12350	10400	22.3
	15 ft	-	-	-	-	*15100	*15100	*13120	12150	-	-	-	-	*12530	8630	24.8
	10 ft	-	-	-	-	*19400	17660	*14990	11640	12850	8370	-	-	11970	7790	26.2
	5 ft	-	-	-	-	*23250	16610	*16910	11140	12610	8140	-	-	11580	7490	26.5
	0 ft	-	-	-	-	*25050	16120	17210	10810	12450	7990	-	-	11890	7650	25.8
	-5 ft	-	-	*24770	*24770	*24900	16050	17100	10710	-	-	-	-	13090	8380	24.1
	-10 ft	-	-	*32010	31560	*22840	16280	*16730	10890	-	-	-	-	*15470	10180	21.1
-15 ft	-	-	*24370	*24370	*17180	16940	-	-	-	-	-	-	*15750	15530	16	
GP Boom: 5.7 m (18' 8") HD Dipper arm: 2.9 m (9' 6") Shoe: 800 mm (2' 8") Counterweight: 4200 kg (9260 lb)	25 ft	-	-	-	-	-	-	-	-	-	-	-	-	*10910	*10910	19.9
	20 ft	-	-	-	-	-	-	*11110	*11110	-	-	-	-	*10090	9430	23.8
	15 ft	-	-	-	-	-	-	*12260	12260	*11700	8620	-	-	*9930	7970	26.2
	10 ft	-	-	-	-	*18100	17910	*14230	11720	*12490	8390	-	-	*10190	7240	27.5
	5 ft	-	-	-	-	*22270	16740	*16320	11170	12610	8140	-	-	10790	6980	27.8
	0 ft	-	-	*12530	*12530	*24630	16110	17200	10790	12390	7940	-	-	11030	7100	27.1
	-5 ft	*14030	*14030	*23460	*23460	*25020	15940	17020	10620	12340	7890	-	-	12010	7690	25.5
	-10 ft	*25560	*25560	*33810	31170	*23540	16090	17120	10710	-	-	-	-	14320	9110	22.7
-15 ft	-	-	*27210	*27210	*19220	16600	-	-	-	-	-	-	*15190	12860	18	
GP Boom: 5.7 m (18' 8") GP Dipper arm: 2.9 m (9' 6") Shoe: 800 mm (2' 8") Counterweight: 4200 kg (9260 lb)	25 ft	-	-	-	-	-	-	-	-	-	-	-	-	*10930	*10930	19.9
	20 ft	-	-	-	-	-	-	*11170	*11170	-	-	-	-	*10120	9480	23.8
	15 ft	-	-	-	-	-	-	*12330	12310	*11760	8670	-	-	*9950	8020	26.2
	10 ft	-	-	-	-	*18180	17980	*14300	11780	*12560	8450	-	-	*10220	7300	27.5
	5 ft	-	-	-	-	*22370	16830	*16400	11240	12670	8200	-	-	10840	7030	27.8
	0 ft	-	-	*12560	*12560	*24740	16210	17270	10860	12460	8000	-	-	11090	7150	27.1
	-5 ft	*14060	*14060	*23490	*23490	*25120	16030	17090	10700	12400	7950	-	-	12060	7750	25.5
	-10 ft	*25580	*25580	*33940	31310	*23640	16180	17190	10790	-	-	-	-	14380	9180	22.7
-15 ft	-	-	*27330	*27330	*19310	16680	-	-	-	-	-	-	*15270	12930	18	

: Along undercarriage, : Across undercarriage, H : Lifting hook related to ground level

1. Machine in "Fine Mode-F" (Power Boost), for lifting capacities.
2. The above loads are in compliance with SAE and ISO Hydraulic Excavator Lift Capacity Standards.
3. Rated loads do not exceed 87% of hydraulic lifting capacity or 75% of tipping load.
4. Rated loads marked with an asterisk ( \* ) are limited by hydraulic capacity rather than tipping load.



# Specifications

## 466 Lifting capacities

EC220E L	H	5 ft		10 ft		15 ft		20 ft		25 ft		30 ft		Max. Reach				
																Max.		
		lb	lb	lb	lb	lb	lb	lb	lb	lb	lb	lb	lb	lb	lb	ft		
<b>GP Boom: 5.7 m (18' 8")</b> <b>GP Dipper arm: 3.5 m (11' 6")</b> <b>Shoe: 800 mm (2' 8")</b> <b>Counterweight: 4200 kg (9260 lb)</b>	25 ft	-	-	-	-	-	-	-	-	-	-	-	-	*10920	10160	23		
	20 ft	-	-	-	-	-	-	-	-	-	*10360	8940	-	-	*10800	8060	26.5	
	15 ft	-	-	-	-	-	-	-	-	-	*10550	8820	-	-	10670	7000	28.6	
	10 ft	-	-	-	-	-	-	-	*10720	*10720	*10550	8820	-	-	10670	7000	28.6	
	5 ft	-	-	-	-	-	-	-	*12590	11980	*11410	8560	-	-	9900	6450	29.8	
	0 ft	-	-	-	-	-	-	-	*14710	11380	*12500	8250	9680	6270	9640	6250	30.1	
	-5 ft	-	-	-	-	-	-	-	*16460	10900	12460	8000	-	-	9820	6340	29.5	
	-10 ft	-	-	-	-	-	-	-	*23490	15960	17040	10650	12310	7860	-	10520	6770	28
<b>HD Boom: 5.7 m (18' 8")</b> <b>ME Dipper arm: 2.0 m (6' 7")</b> <b>Shoe: 800 mm (2' 8")</b> <b>Counterweight: 4200 kg (9260 lb)</b>	-15 ft	*38240	*38240	*28240	*28240	*20080	16320	*14650	10920	-	-	-	-	-	-	*12990	10010	21.5
	25 ft	-	-	-	-	-	-	-	-	-	-	-	-	-	*13930	*13930	15.7	
	20 ft	-	-	-	-	-	-	-	*13310	12180	-	-	-	-	*13380	11710	20.5	
	15 ft	-	-	-	-	-	-	-	*16490	*16490	*13970	11910	-	-	*13450	9410	23.2	
	10 ft	-	-	-	-	-	-	-	*20670	17140	*15640	11390	-	-	12980	8380	24.6	
	5 ft	-	-	-	-	-	-	-	*17310	10920	-	-	-	-	12510	8030	25	
	0 ft	-	-	-	-	-	-	-	*24960	15850	17060	10640	-	-	12910	8240	24.3	
	-5 ft	-	-	-	-	-	-	-	*24140	15910	17040	10630	-	-	14470	9170	22.4	
<b>HD Boom: 5.7 m (18' 8")</b> <b>HD Dipper arm: 2.5 m (8' 2")</b> <b>Shoe: 800 mm (2' 8")</b> <b>Counterweight: 4200 kg (9260 lb)</b>	-10 ft	-	-	*28830	*28830	*21330	16260	-	-	-	-	-	-	*16150	11620	19.1		
	25 ft	-	-	-	-	-	-	-	-	-	-	-	-	*12480	*12480	18		
	20 ft	-	-	-	-	-	-	-	*12040	*12040	-	-	-	-	*12270	10370	22.3	
	15 ft	-	-	-	-	-	-	-	*15030	*15030	*13040	12120	-	-	*12440	8580	24.8	
	10 ft	-	-	-	-	-	-	-	*19280	17590	*14880	11590	12820	8310	-	11930	7730	26.2
	5 ft	-	-	-	-	-	-	-	*23090	16490	*16790	11060	12560	8080	-	11530	7430	26.5
	0 ft	-	-	-	-	-	-	-	*24860	15980	17140	10720	12390	7920	-	11830	7580	25.8
	-5 ft	-	-	*24770	*24770	*24710	15900	17020	10610	-	-	-	-	-	13030	8300	24.1	
<b>HD Boom: 5.7 m (18' 8")</b> <b>HD Dipper arm: 2.9 m (9' 6")</b> <b>Shoe: 800 mm (2' 8")</b> <b>Counterweight: 4200 kg (9260 lb)</b>	-10 ft	-	-	*31740	31330	*22660	16140	*16590	10800	-	-	-	-	*15340	10100	21.1		
	-15 ft	-	-	*24140	*24140	*17010	16840	-	-	-	-	-	-	*15600	15430	16		
	25 ft	-	-	-	-	-	-	-	-	-	-	-	-	*10910	*10910	19.9		
	20 ft	-	-	-	-	-	-	-	*11060	*11060	-	-	-	-	*10090	9400	23.8	
	15 ft	-	-	-	-	-	-	-	*12190	*12190	*11620	8580	-	-	*9930	7920	26.2	
	10 ft	-	-	-	-	-	-	-	*17990	17860	*14140	11680	*12400	8350	-	*10190	7190	27.5
	5 ft	-	-	-	-	-	-	-	*22120	16640	*16200	11100	12560	8070	-	10740	6910	27.8
	0 ft	-	-	*12530	*12530	*24450	15980	17130	10700	12340	7870	-	-	-	10980	7030	27.1	
-5 ft	*14030	*14030	*23460	*23460	*24820	15790	16940	10530	12280	7810	-	-	-	11950	7620	25.5		
-10 ft	*25560	*25560	*33530	30930	*23350	15950	17040	10620	-	-	-	-	-	14260	9040	22.7		
-15 ft	-	-	*26960	*26960	*19050	16490	-	-	-	-	-	-	-	*15050	12770	18		

: Along undercarriage, : Across undercarriage, H : Lifting hook related to ground level

1. Machine in "Fine Mode-F" (Power Boost), for lifting capacities.
2. The above loads are in compliance with SAE and ISO Hydraulic Excavator Lift Capacity Standards.
3. Rated loads do not exceed 87% of hydraulic lifting capacity or 75% of tipping load.
4. Rated loads marked with an asterisk ( \* ) are limited by hydraulic capacity rather than tipping load.



Specifications  
**Lifting capacities 467**

EC220E L	H	5 ft		10 ft		15 ft		20 ft		25 ft		30 ft		Max. Reach			
																Max.	
		lb	lb	lb	lb	lb	lb	lb	lb	lb	lb	lb	lb	lb	lb	ft	
<b>HD Boom: 5.7 m (18' 8")</b> <b>GP Dipper arm: 2.9 m (9' 6")</b> <b>Shoe: 800 mm (2' 8")</b> <b>Counterweight: 4200 kg (9260 lb)</b>	25 ft	-	-	-	-	-	-	-	-	-	-	-	-	*10930	*10930	19.9	
	20 ft	-	-	-	-	-	-	-	*11110	*11110	-	-	-	*10120	9450	23.8	
	15 ft	-	-	-	-	-	-	-	*12260	*12260	*11680	8630	-	-	*9950	7970	26.2
	10 ft	-	-	-	-	*18070	17930	*14210	11740	*12470	8400	-	-	*10220	7240	27.5	
	5 ft	-	-	-	-	*22220	16730	*16280	11170	12620	8130	-	-	10800	6970	27.8	
	0 ft	-	-	*12560	*12560	*24550	16080	17200	10770	12400	7930	-	-	11030	7090	27.1	
	-5 ft	*14060	*14060	*23490	*23490	*24930	15890	17010	10600	12340	7880	-	-	12010	7680	25.5	
	-10 ft	*25580	*25580	*33660	31070	*23460	16040	17110	10690	-	-	-	-	14320	9100	22.7	
	-15 ft	-	-	*27080	*27080	*19140	16570	-	-	-	-	-	-	*15130	12840	18	
<b>HD Boom: 5.7 m (18' 8")</b> <b>GP Dipper arm: 3.5 m (11' 6")</b> <b>Shoe: 800 mm (2' 8")</b> <b>Counterweight: 4200 kg (9260 lb)</b>	25 ft	-	-	-	-	-	-	-	-	-	-	-	-	*10860	10140	23	
	20 ft	-	-	-	-	-	-	-	-	*10290	8920	-	-	*10730	8020	26.5	
	15 ft	-	-	-	-	-	-	-	*10660	*10660	*10480	8800	-	-	10640	6960	28.6
	10 ft	-	-	-	-	-	-	-	*12510	11950	*11330	8520	-	-	9860	6400	29.8
	5 ft	-	-	-	-	-	-	-	*14610	11320	*12410	8200	9630	6220	9590	6190	30.1
	0 ft	-	-	-	-	-	-	-	*16340	10820	12410	7930	-	-	9770	6280	29.5
	-5 ft	-	-	-	-	*23310	15820	16970	10550	12260	7790	-	-	10470	6710	28	
	-10 ft	-	-	*33090	30580	*22680	15840	16940	10530	12330	7860	-	-	12040	7690	25.5	
	-15 ft	*38240	*38240	*28000	*28000	*19910	16200	*14520	10840	-	-	-	-	*12870	9930	21.5	

: Along undercarriage, : Across undercarriage, H : Lifting hook related to ground level

1. Machine in "Fine Mode-F" (Power Boost), for lifting capacities.
2. The above loads are in compliance with SAE and ISO Hydraulic Excavator Lift Capacity Standards.
3. Rated loads do not exceed 87% of hydraulic lifting capacity or 75% of tipping load.
4. Rated loads marked with an asterisk ( \* ) are limited by hydraulic capacity rather than tipping load.



# Specifications

## 468 Lifting capacities

EC220E LR	H	5 ft		10 ft		15 ft		20 ft		25 ft		30 ft	
		lb	lb	lb	lb	lb	lb	lb	lb	lb	lb	lb	lb
LR Boom: 8.85 m (29' 0") LR Dipper arm: 6.25 m (20' 6") Shoe: 800 mm (2' 8") Counterweight: 5000 kg (11030 lb)	40 ft	-	-	-	-	-	-	-	-	-	-	-	-
	35 ft	-	-	-	-	-	-	-	-	-	-	-	-
	30 ft	-	-	-	-	-	-	-	-	-	-	-	-
	25 ft	-	-	-	-	-	-	-	-	-	-	-	-
	20 ft	-	-	-	-	-	-	-	-	-	-	-	-
	15 ft	-	-	-	-	-	-	-	-	-	-	-	-
	10 ft	-	-	-	-	*13500	*13500	*9900	*9900	*8060	*8060	*6960	6620
	5 ft	-	-	-	-	*17430	15840	*12040	10860	*9370	8000	*7820	6140
	0 ft	-	-	*5610	*5610	*12880	*12880	*13750	9870	*10520	7360	*8600	5710
	-5 ft	*5870	*5870	*7540	*7540	*12780	*12780	*14860	9270	*11380	6910	8920	5390
	-10 ft	*7950	*7950	*9730	*9730	*14300	13490	*15400	8970	11220	6630	8690	5170
	-15 ft	*10120	*10120	*12140	*12140	*16680	13560	15410	8890	11100	6520	8580	5070
	-20 ft	*12430	*12430	*14840	*14840	*19810	13800	*14980	8980	11130	6550	8600	5080
	-25 ft	*14950	*14950	*17950	*17950	*18260	14230	*13970	9230	*11130	6710	8750	5220
-30 ft	-	-	*21620	*21620	*15730	14860	*12200	9650	*9710	7040	*7640	5540	
-35 ft	-	-	-	-	-	-	*9090	*9090	-	-	-	-	

EC220E LR	H	35 ft		40 ft		45 ft		Max. Reach		Max. ft
		lb	lb	lb	lb	lb	lb	lb	lb	
LR Boom: 8.85 m (29' 0") LR Dipper arm: 6.25 m (20' 6") Shoe: 800 mm (2' 8") Counterweight: 5000 kg (11030 lb)	40 ft	-	-	-	-	-	-	*1950	*1950	33.1
	35 ft	*3530	*3530	-	-	-	-	*1780	*1780	37.6
	30 ft	*4750	*4750	*2610	*2610	-	-	*1680	*1680	41.1
	25 ft	*4910	*4910	*4190	*4190	-	-	*1630	*1630	43.7
	20 ft	*5240	*5240	*5120	4420	*2230	*2230	*1620	*1620	45.6
	15 ft	*5700	5450	*5410	4260	*3440	3330	*1650	*1650	46.9
	10 ft	*6250	5140	*5770	4060	*4230	3220	*1710	*1710	47.6
	5 ft	*6830	4830	*6160	3850	*4720	3090	*1810	*1810	47.8
	0 ft	*7370	4540	6070	3660	*4830	2980	*1950	*1950	47.4
	-5 ft	7170	4310	5910	3510	*4250	2890	*2150	*2150	46.5
	-10 ft	7010	4160	5800	3410	*2460	*2460	*2430	*2430	45
	-15 ft	6930	4090	5780	3380	-	-	*2850	*2850	42.9
	-20 ft	6960	4110	*3580	3460	-	-	*3490	3460	40
	-25 ft	7130	4270	-	-	-	-	*4590	4100	36.3
-30 ft	-	-	-	-	-	-	*6990	5280	31.2	
-35 ft	-	-	-	-	-	-	*7140	*7140	24.2	

: Along undercarriage, : Across undercarriage, H : Lifting hook related to ground level

1. Machine in "Fine Mode-F" (Power Boost), for lifting capacities.
2. The above loads are in compliance with SAE and ISO Hydraulic Excavator Lift Capacity Standards.
3. Rated loads do not exceed 87% of hydraulic lifting capacity or 75% of tipping load.
4. Rated loads marked with an asterisk ( \* ) are limited by hydraulic capacity rather than tipping load.





## Service history

Service 500 hours		Type of service	Signature and stamp
Date	Hours	<input type="checkbox"/> First 500 hours <input type="checkbox"/> Service and maintenance	
Service 1000 hours		Type of service	Signature and stamp
Date	Hours	<input type="checkbox"/> Service and maintenance	
Service 1500 hours		Type of service	Signature and stamp
Date	Hours	<input type="checkbox"/> Service and maintenance	
Service 2000 hours		Type of service	Signature and stamp
Date	Hours	<input type="checkbox"/> Service and maintenance	
Service 2500 hours		Type of service	Signature and stamp
Date	Hours	<input type="checkbox"/> Service and maintenance	
Service 3000 hours		Type of service	Signature and stamp
Date	Hours	<input type="checkbox"/> Service and maintenance	
Service 3500 hours		Type of service	Signature and stamp
Date	Hours	<input type="checkbox"/> Service and maintenance	
Service 4000 hours		Type of service	Signature and stamp
Date	Hours	<input type="checkbox"/> Service and maintenance	
Service 4500 hours		Type of service	Signature and stamp
Date	Hours	<input type="checkbox"/> Service and maintenance	





**470 Specifications**  
**Service history**

Service 5000 hours		Type of service	Signature and stamp
Date	Hours	<input type="checkbox"/> Service and maintenance	

Service 5500 hours		Type of service	Signature and stamp
Date	Hours	<input type="checkbox"/> Service and maintenance	

Service 6000 hours		Type of service	Signature and stamp
Date	Hours	<input type="checkbox"/> Service and maintenance	

Service 6500 hours		Type of service	Signature and stamp
Date	Hours	<input type="checkbox"/> Service and maintenance	

Service 7000 hours		Type of service	Signature and stamp
Date	Hours	<input type="checkbox"/> Service and maintenance	

Service 7500 hours		Type of service	Signature and stamp
Date	Hours	<input type="checkbox"/> Service and maintenance	

Service 8000 hours		Type of service	Signature and stamp
Date	Hours	<input type="checkbox"/> Service and maintenance	

Service 8500 hours		Type of service	Signature and stamp
Date	Hours	<input type="checkbox"/> Service and maintenance	

Service 9000 hours		Type of service	Signature and stamp
Date	Hours	<input type="checkbox"/> Service and maintenance	



Specifications  
**Service history**     **471**

Service 9500 hours		Type of service <input type="checkbox"/> Service and maintenance	Signature and stamp
Date	Hours		
Service 10000 hours		Type of service <input type="checkbox"/> Service and maintenance	Signature and stamp
Date	Hours		
Service 10500 hours		Type of service <input type="checkbox"/> Service and maintenance	Signature and stamp
Date	Hours		
Service 11000 hours		Type of service <input type="checkbox"/> Service and maintenance	Signature and stamp
Date	Hours		
Service 11500 hours		Type of service <input type="checkbox"/> Service and maintenance	Signature and stamp
Date	Hours		
Service 12000 hours		Type of service <input type="checkbox"/> Service and maintenance	Signature and stamp
Date	Hours		



A series of horizontal dotted lines for writing, consisting of 25 lines.



## Alphabetical index

### A

Accidents.....	169
Accumulator, emergency operation.....	338
Accumulator, handling.....	338
Accumulator, pressure releasing.....	339
AdBlue®/DEF.....	356
AdBlue®/DEF information.....	10
AdBlue®/DEF tank, draining.....	319
AdBlue®/DEF, filling.....	317
Air compressor.....	124
Air compressor, air filter, cleaning.....	302
Air compressor, air filter, replacing.....	313
Air compressor, air tank water, draining.....	301
Air conditioning filter, cleaning and replacing.....	305, 311
Air conditioning filter, cleaning and replacing.....	305, 311
Alarm texts.....	65
Alternative fuels.....	350
Arrival Inspection.....	279
Attachment quick coupler.....	222, 233
Attachment quick coupler.....	222, 233
Attachments.....	220
Attachments, connecting and disconnecting.....	222
Audio system.....	125
Auxiliary heater.....	136, 145
Auxiliary heater.....	136, 145

### B

Batteries.....	276
Batteries, charging.....	321
Battery disconnect switch.....	266
Battery electrolyte level, check.....	307
Before service, read.....	263
Boom and dipper arm.....	428
Boom float position, description.....	220
Bucket teeth, replacing.....	333, 335
Bucket teeth, replacing.....	333, 335
Buckets.....	240

### C

Cab.....	13, 105, 365
Cab.....	13, 105, 365
Cab.....	13, 105, 365
Cab door hinges, greasing.....	309
Cab prefilter, cleaning and replacing.....	301, 311
Cab prefilter, cleaning and replacing.....	301, 311
Carbon dioxide emissions.....	361
CareTrack.....	17
CareTrack with anti-theft.....	69

CE-marking, EMC-directive.....	19
Change capacities.....	358
Change intervals.....	359
Cleaning engine compartment.....	325
Cleaning machine.....	323
Climate control system.....	115
Communication equipment, installation..	22
Control lockout system.....	109
Control types for X1 and X3 operation....	78
Controls.....	94
Coolant.....	312, 347
Coolant.....	312, 347
Coolant level, checking.....	331

### D

Delivery Inspection.....	279
Delivery Instructions.....	279
Demolition work.....	218
Digging forces.....	437
Dimensions.....	418
Display unit.....	43
Door.....	119

### E

Electrical distribution box.....	266
Electrical system.....	12, 362
Electrical system.....	12, 362
Emergency exit.....	123
Emission compliance.....	187
Engine.....	9, 361
Engine.....	9, 361
Engine air cleaner.....	326
Engine air cleaner cover, cleaning.....	330
Engine air cleaner primary filter, cleaning and replacing.....	326
Engine air cleaner primary filter, replacing.....	311
Engine air cleaner secondary filter, replacing.....	314, 329
Engine air cleaner secondary filter, replacing.....	314, 329
Engine block heater.....	174
Engine oil.....	346
Engine oil level, checking.....	291, 315
Engine oil level, checking.....	291, 315
Engine, specifications.....	361
Entering, leaving and climbing the machine.....	269
Entering, leaving and climbing the machine.....	269
Environmental requirements.....	9
Equipment.....	16
Excavator unit, greasing.....	290, 296
Excavator unit, greasing.....	290, 296
Exhaust aftertreatment system.....	11, 180



Alphabetical index

474

Exhaust aftertreatment system.....	11, 180	Maintenance service, every 250 hours.	298
Exhaust aftertreatment system, alarms requiring special actions.....	188	Maintenance service, every 4000 hours	314
<b>F</b>		Maintenance service, every 50 hours...	291
Fire extinguisher, location.....	123	Maintenance service, every 500 hours.	303
Fire prevention.....	270	Maintenance service, when required....	315
Fuel.....	350	Maintenance under special environmental conditions.....	341
Fuel system.....	350	Measurements before transporting machine.....	197
Fuel system, bleeding.....	320	Measures before operating.....	172
Fuel, filling.....	315	<b>O</b>	
<b>G</b>		Oil bath air cleaner, checking.....	293
Grease.....	349	Oil bath air cleaner, cleaning.....	311, 331
Ground pressure.....	371	Oil bath air cleaner, cleaning.....	311, 331
<b>H</b>		Operating.....	179
Hammer.....	242	Operating on public roads.....	171
Hammer (hydraulic breaker).....	242	Operator comfort.....	110
Handling hazardous materials.....	273	Operator obligations.....	167
Handling line, tubes and hoses.....	278	Operator safety.....	169
High voltage overhead power line.....	209	Operator seat.....	110
Hose rupture valves.....	249	Operator's manual, storage.....	123
Hour meter.....	121	Overload warning.....	256, 310
Hydraulic oil.....	268, 348	Overload warning.....	256, 310
Hydraulic oil.....	268, 348	<b>P</b>	
Hydraulic oil level, checking.....	292	Paint finish maintenance.....	324
Hydraulic system.....	14, 267, 367	Parking.....	193
Hydraulic system.....	14, 267, 367	Product plates.....	24
Hydraulic system.....	14, 267, 367	<b>R</b>	
Hydraulic system, releasing pressure...	337	Radiator and coolers, cleaning.....	303, 331
Hydraulic system, warming up.....	177	Radiator and coolers, cleaning.....	303, 331
<b>I</b>		Rain shield.....	120
Information and warning decals.....	26	Recommended bucket sizes.....	434
Instrument panel, front.....	37	Recommended intervals for critical parts.....	340
Instrument panel, left.....	35	Recommended lubricants.....	343
Instrument panel, rear.....	92	Recommended lubricants.....	343
Instrument panel, right.....	79	Refrigerant.....	277, 366
Intended use.....	9	Refrigerant.....	277, 366
<b>L</b>		Regeneration.....	180
Lifting capacities.....	439	Retrieving and towing.....	195
Lifting machine.....	202	Reversible fan.....	219
Lifting objects.....	252	Roof.....	121
Logged machine data.....	17	Rules for digging.....	206
Lubrication.....	281	Running-in instructions.....	161
Lubrication and service chart 279, 281, 283		<b>S</b>	
Lubrication and service chart 279, 281, 283		Safety components.....	23
Lubrication and service chart 279, 281, 283		Safety rules when operating.....	167
<b>M</b>		Seat belt.....	114
Machine view.....	18	Selecting track shoes.....	251
Machine weights.....	369	Service capacities and change intervals	358
Maintenance service, every 10 hours...	289	Service history.....	279, 469
Maintenance service, every 1000 hours	308	Service history.....	279, 469
Maintenance service, every 2000 hours	311		



---

Service position.....	262
Service Programme.....	280
Signalling diagram.....	258
Starting engine.....	173
Starting engine in cold weather.....	174
Starting with booster batteries.....	175
Stopping.....	192
Storage compartment.....	122
Sun shade.....	120
Sun shield.....	120
Swing bath, grease checking.....	309
Swing drive unit.....	298
Swing drive unit, checking oil level.....	299
Swing gear bearing, greasing.....	300
Symbol key.....	282
<b>T</b>	
Touch-up painting.....	324
Track drive unit.....	308
Track drive unit, checking oil level.....	309
Track unit, adjusting tension.....	332
Track unit, checking shoe screws.....	289
Track unit, checking tension.....	294
Transporting machine.....	197
Tying down machine.....	200
<b>U</b>	
Underground cables and pipes.....	213
<b>V</b>	
Visibility.....	162
Vision system.....	131
Volvo Smart View.....	133
<b>W</b>	
Warming up.....	176
Washer reservoir.....	290
Water separator, draining.....	319
Welding.....	322
Whole-body vibrations.....	204
Windows.....	118
Working in cold weather.....	217
Working in water and on boggy ground	216
Working on slopes.....	214
Working ranges.....	430
Working with buckets.....	241
Working with long range attachments...	248
Working within dangerous areas.....	209





A series of horizontal dotted lines for writing, consisting of 20 lines spaced evenly down the page.



A series of horizontal dotted lines for writing, consisting of 20 lines spaced evenly down the page.





Alphabetical index

478

---